

# Premium Leisure LLC

SWIM SPAS OWNER'S MANUAL  
MODELS: SWIMMER'S EDGE 18,



Premium Leisure, LLC  
6101 45<sup>th</sup> St. N.  
St. Petersburg, FL 33714  
727.573.9611  
[www.PremiumLeisure.com](http://www.PremiumLeisure.com)

Part Number 7068MM

Revised 12/2014

## Owner's Information

Dealer:

Date Purchased: \_\_\_\_\_  
Company: \_\_\_\_\_  
Address: \_\_\_\_\_  
Telephone: \_\_\_\_\_

Installer:

Date Installed: \_\_\_\_\_  
Company: \_\_\_\_\_  
Address: \_\_\_\_\_  
Telephone: \_\_\_\_\_

Swim Spa:

Date Delivered: \_\_\_\_\_  
Model: \_\_\_\_\_  
Color: \_\_\_\_\_  
Serial Number: \_\_\_\_\_

Your unique swim spa serial number is located on a data plate outside the cabinet at ground level. When calling for service, please have your serial number in hand.



# Premium Leisure™ Swimmer's Edge Owner's Manual Table of Contents

Introduction .....	2
Important Safety Information .....	2
Site Selection and Installation (Electrical Connections).....	<b>Error! Bookmark not defined.</b>
Startup.....	23
Water Balancing .....	30
Topside Controls and Operation .....	31
Stereo System.....	41
Cover.....	42
Frequently Asked Questions .....	43
Troubleshooting .....	45
Maintenance and Care .....	48
Specifications .....	52
Certificate of Verification .....	60

**Important:** Premium Leisure is dedicated to offering you the best in customer satisfaction and service. Be sure to read, complete, sign, and **send in the limited warranty card within 30 days of purchase or register online** at <http://premiumleisure.com/owners.shtml> to ensure you understand what you are entitled to in terms of service. If you have any questions, you can call our customer care center at 727.573.9611.

Printed in the U.S.A.

Version 1.0

Revised 12/2014

Part # 7068MM

Copyright © 2010, Premium Leisure LLC. All rights reserved. No portion of this manual may be reproduced in any manner without express written permission of Premium Leisure LLC. Premium Leisure™ Swim spas and Thermazone™ are trademarks of Premium Leisure LLC. All other brands, product names, company names, trade names, trademarks, and service marks used are the property of their respective owners. Premium Leisure LLC may make product modifications and enhancements. Specifications may change without notice. International products may be configured differently to meet local electrical requirements. Dimensions are approximate. Patents pending.

# Introduction

Your choice of a Premium Leisure™ brand swim spa from Premium Leisure LLC indicates that you are devoted to excellence. The management and staff appreciate your patronage and takes pride in the tradition of quality swim spas that our company represents.

To properly acquaint yourself with your swim spa, we suggest that you take time to read through this manual before hook up and operation. Doing so will familiarize you with important operating and safety procedures, thereby ensuring an enjoyable experience right from the start.

If you need any more information than this manual provides, feel free to visit our Web site at [www.PremiumLeisure.com](http://www.PremiumLeisure.com) or call our customer care center, at 727.573.9611.

**⚠ WARNING:** This manual was written to ensure the proper use and installation of your swim spa. Any modifications to the procedures outlined in this manual may result in voiding your warranty.

This manual and its contents are subject to change without notice. Although we have prepared this manual as accurate as possible, we are not liable for errors or omissions; loss, injury, or damages caused by improper installation; or use of swim spa (improper or otherwise).

You new swim spa is made with quality synthetic cabinet materials. Synthetic materials won't fade and are nearly invulnerable to mold and mildew. Where wood splits, cracks, and stains, synthetic materials stand in timeless perfection.



**Figure 1 – Swimmer in the Dual Zone 18**

**| NO DIVING**

**DANGER: DIVING MY RESULT IN SERIOUS INJURY OR DEATH**

## Important Safety Information

### IMPORTANT SAFETY INSTRUCTIONS SAVE THESE INSTRUCTIONS

Your physiological response to hot water depends on subjective factors such as age, health, pregnant women, temperature sensitivities, chemical sensitivities, and medical history. *Always* consult a physician before using a swim spa to understand your particular tolerance and limitations.

#### READ AND FOLLOW ALL INSTRUCTIONS

**WARNING** – To reduce the risk of injury, do not permit children to use this product unless they are closely supervised at all times.

A wire connector is provided on this unit to connect a minimum #6 (AWG) solid copper conductor between this unit and any metal equipment, metal enclosures of electrical equipment, metal water pipe, or conduit within 5 feet (1.5 m) of the unit.

**\*\* For units with GFCI:** ⚠ **Warning** – This product is provided with a ground-fault circuit interrupter located in the main panel. The GFCI must be tested before each spa use.

### Dangers

- ⚠ **RISK OF ACCIDENTAL DROWNING:** Extreme caution must be exercised to prevent unauthorized access by children. To avoid accidents, ensure that children cannot use this spa unless they are supervised at all times. Always cover the swim spa and use safety locks when it is not in use.
- ⚠ **RISK OF INJURY:** The suction fittings in this spa are sized to match the specific water flow created by the pump. Should the need arise to replace the suction fittings or the pump, be sure that the flow rates are compatible. Never operate the spa if the suction fittings are broken or missing. Never replace a suction fitting with one rated less than the flow rate marked on the original suction fitting.
- ⚠ **RISK OF ELECTRIC SHOCK:** Install at least 5 feet (1.5 m) from all metal surfaces. As an alternative, a spa may be installed within 5 feet of metal surfaces if each metal surface is permanently connected by a minimum #6 (AWG) solid copper conductor to the wire connector on the terminal box that is provided for this purpose.
- ⚠ **RISK OF ELECTRIC SHOCK:** Do not permit any electric appliance, such as a light, telephone, radio or television, within 5 feet (1.5 m) of a spa. Do not operate such an appliance from either inside the swim spa or when you are wet, unless such appliances are built-in by the manufacturer.

#### NO DIVING

**DANGER: DIVING MY RESULT IN SERIOUS INJURY OR DEATH**

## Warnings

- ⚠ TO REDUCE THE RISK OF INJURY:**
- The water in a spa should never exceed 40°C (104°F). Water temperatures between 38°C (100°F) and 40°C (104°F) are considered safe for a healthy adult. Lower water temperatures are recommended for young children and when spa use exceeds 10 minutes.
  - Since excessive water temperatures have a high potential for causing fetal damage during the early months of pregnancy, pregnant or possible pregnant women should limit spa water temperatures to 38°C (100°F).
  - Before entering a spa/swim spa, the user should measure the water temperature since the tolerance of water temperature regulating devices varies.
  - The use of alcohol, drugs or medication before or during spa/swim spa use may lead to unconsciousness with the possibility of drowning.
  - Obese persons and persons with a history of heart disease, low or high blood pressure, circulatory system problems, or diabetes should consult a physician before using a spa.
  - Persons using medication should consult a physician before using a spa/swim spa since some medication may include drowsiness while other medication may affect heart rate, blood pressure and circulation.
- ⚠ Do not connect auxiliary components (such as headphones, cables, and additional speakers) to the stereo (if equipped).
- ⚠ Do not use a swim spa immediately following strenuous exercise.
- ⚠ Do not use your swim spa alone.
- ⚠ Lock the cover on your swim spa when not in use.
- ⚠ Persons with infectious diseases should not use a swim spa.
- ⚠ Replace audio components only with identical components.
- ⚠ Do not leave the CD/Stereo/MP3 access door open on the stereo (if equipped).
- ⚠ Some types of hair dye can react with the sanitizers in your swim spa water causing your hair to change color. Use at your own risk.
- ⚠ Water normally splashes out of a swim spa during typical use. Install an adequate perimeter that provides sound footing.
- ⚠ Do not turn your swim spa on/off from a wall switch, ground fault circuit interrupter, circuit breaker, fuse, or by plugging/unplugging it.
- ⚠ Remove all jewelry, metal, and watches from your person before entering your swim spa.
- ⚠ Keep all breakables away from the swim spa area.
- ⚠ Maintain water balance in accordance with instructions.
- ⚠ Do not sit on lip of the spa.

**NO DIVING**

## DANGER: DIVING MY RESULT IN SERIOUS INJURY OR DEATH

### Warning Sign



**Warning Sign Must Be Posted** – The red WARNING sign like the one shown is packed with your new swim spa. This sign must be posted in a prominent place in close proximity to the swim spa installation site immediately upon completion of swim spa installation.

Figure 2 – Warning Sign

Important: It is extremely important that this sign be permanently placed in clear view of persons using the swim spa. Occasional swim spa users may not be aware of some of the dangers hot water poses to pregnant women, small children, seniors, and people under the influence of alcohol. If you did not receive a warning sign or your sign has become damaged, please call your local dealer for a replacement.

### Hyperthermia

To reduce the risk of injury, the water temperature in a swim spa should never exceed 104°F (40°C). Water temperatures between 100°F (38°C) and 104°F (40°C) are considered safe for a healthy adult. Lower water temperatures are recommended for young children, senior citizens, persons with sensitivities, and when swim spa use exceeds 10 minutes.

**WATER TEMPERATURE IN EXCESS OF 100°F (38°C) MAY BE INJURIOUS TO YOUR HEALTH.**

Hyperthermia occurs when the internal temperature of the body reaches a level several degrees above the normal body temperature of 98.6°F (37°C). The symptoms of hyperthermia include drowsiness, lethargy, and an increase in the internal temperature of the body. The effects of hyperthermia include:

- ⚠ Unawareness of impending hazard
- ⚠ Failure to perceive heat
- ⚠ Failure to recognize the need to exit swim spa
- ⚠ Physical inability to exit swim spa
- ⚠ Fetal damage in pregnant women
- ⚠ Unconsciousness and danger of drowning

**If you sense any of the symptoms of hyperthermia, safely exit the swim spa immediately.**

# SAVE THESE INSTRUCTIONS

## Basic Safety Guidelines

Your hot tub is meant to be enjoyable, healthful, and relaxing. Below are some basic safety guidelines to follow every time you use your hot tub.

- Always check the temperature of your hot tub before entering. High water temperatures can be hazardous to your health.
- Persons suffering from heart disease, diabetes, high or low blood pressure, and pregnant women should consult a doctor before using your hot tub.
- Persons under the influence of medication, drugs, or alcohol should not be allowed into your hot tub.
- Remove all jewelry, metal, and watches from your person before entering your hot tub.
- Do not allow children to use your hot tub without continuous supervision of an adult.
- Do not use your hot tub alone.
- Test the ground fault circuit interrupter (GFCI) breaker prior to using your hot tub each time to ensure it operates properly.
- Any electrical devices near your hot tub must be GFCI protected and out of reach from inside the hot tub.
- Keep all breakables away from the hot tub area.
- Lock the cover on your hot tub when not in use.
- Enter and exit the hot tub slowly. Wet surfaces can be slippery.
- Prolonged immersion can be hazardous to your health.

Maintain water chemistry in accordance with manufacturer's instructions.

- The hot tub is not to be used by persons with reduced physical, sensory or mental capabilities, or lack of experience and knowledge, unless they have been given supervision or instruction
- Do not sit on lip of spa.

**NO DIVING**

**DANGER: DIVING MY RESULT IN SERIOUS INJURY OR DEATH**

## Basic Water Quality Guidelines

- *During the initial filling of the spa, add a sequestering agent to combat suspended minerals in the water. Allow water to circulate and filter for at least 12 hours before adding any other chemicals.*
- *Test water for PH, total Alkalinity, and Calcium hardness. The PH should be 7.2-7.8 and the total Alkalinity 80-180 PPM. Calcium hardness levels should be maintained between 150 and 400 PPM. Adjust PH and total Alkalinity (TA) utilizing the directions on the chemical bottles. Wait 15-30 minutes, test and adjust if necessary.*
- *Add 2 ounces of concentrated chlorinating granules (sodium Dichlor-s-triazinetreone) on initial start up to begin sanitizing the spa water. It is important not to add the chlorinating granules until the PH, alkalinity and calcium hardness have been adjusted to their proper levels.*
- *Check spa water with test strip for proper sanitation levels and adjust accordingly to the proper levels. Free chlorine should be 2-4 PPM.*
- *We recommend a minimum level of 2 PPM residual chlorine be maintained in spa water. Be sure the pumps are running when adding chlorine or non chlorine shock/oxidizer.*
- *Add 1 ounce of non-chlorine shock/oxidizer or ½ ounce of chlorine to the spa water after each spa use.*

## For Swim spas Equipped with Audio Components

Audio components are optional and not available on all models.

 **WARNING: Prevent Electrocuton:** Do not connect any auxiliary components – for example, cable, additional speakers, headphones, etc., – to the system.

 **Caution: Risk of Electric Shock:** Do not leave audio compartment door open. Replace audio components only with identical components.

## Site Selection and Installation

Proper planning is an important consideration when installing your new swim spa. Site selection is a critical step and requires serious thought. Planning ahead makes the installation process easier. The following information is provided to assist you in site preparations.

- 1) Always comply with local building codes and obtain any necessary permits. You may also need to consult with an engineer to address your specific design needs.
- 2) Contact an electrician to assess your electrical needs, install wiring, and assure a safe operation.
- 3) Position your swim spa with proper access to water, drainage, and electricity.
- 4) For **external installations**, place your swim spa on a uniform solid, flat surface designed to properly support its weight. For external installations, a level concrete pad or properly constructed deck capable of supporting 200 lbs/ft<sup>2</sup> (925 kg/m<sup>2</sup>) should be installed. For best results, we suggest the installation of a level concrete pad. Dig out and level the ground 8-12 inches (20-30 cm) below your desired base level. Install 4-6 inches (10-15 cm) of crushed stone. Next, install 4-6 inches (10-15 cm) of poured concrete and level it with a broom-type finish. Decks constructed flush to the swim spa should slope away for proper run off. In regions where freeze/thaw occurs, or where there will be custom decking abutting the swim spa, we recommend the installation of poured concrete footings extending below the frost line beneath the pad to prevent the possibility of future shifting.
- 5) For **internal installations**, check the load carrying capabilities of the floor on which the swim spa will reside. The ceiling should be more than 10 feet high (for safe entry and use), the floor should have a drain for splash over and the room should have a window or exhaust fan with humidistat for ventilation. If this is not possible, indoor/outdoor carpeting and the use of a dehumidifier while the cover is off should be adequate.
- 6) For **partial in-ground installations** (not recommended), follow these tips: In non-freezing climates it is sufficient to ensure that the base of the hole or cavity created for the swim spa simply has a stable, compacted base. Where the climate permits, should you choose to backfill directly against the swim spa, a clear sand backfill is suggested. Never fill using raw earth and never cover electrical components or plumbing connections. • In climates where freeze/thaw occurs, it is necessary that a proper poured concrete base, complete with concrete footings. • In areas with a high ground water table, the concrete base, as well as a concrete or wood retaining wall to hold back the earth, is suggested. This forms a box or "crib/vault" where the swim spa is placed. After excavating the installation site for your Premium Leisure swim spa, ensure that the soil underlying the foundation is capable of supporting a minimum of 1,000 lbs/ ft<sup>2</sup> or 12,206 kg/m<sup>2</sup> • ALWAYS ensure that there is good drainage, via a properly designed (gravel) drain system and/or a sump pump, to prevent ground water flooding damage to the

support equipment or structure. Install protective waterproof conduit to house light, or topside control cables that must be buried. Access for future service must be considered at the time of design and installation. Difficult access can result in supplemental service labor charges not covered by the factory warranty. Consider easily removable deck materials.

- 7) Assure that your swim spa will fit into the space you have chosen and the delivery route will accommodate its large size. In most cases, a crane will be necessary for the delivery.
- 8) Provide adequate ventilation for the humidity created by your swim spa. In most cases, a Swim spa Hard Cover is sufficient.
- 9) Protect the pumps and all equipment from the weather by ensuring the cabinet panels are secure at all times.
- 10) Allow 36 inches (1 meter) of unobstructed access to all sides of your swim spa for normal servicing.
- 11) Contact your local building code department to determine if a building permit is necessary and for information on applicable bylaws (distance from property lines, buildings, fencing requirements, etc). In most cases, the shallow depth of the unit could result in it being classified as a *portable* swim spa by building regulations (as opposed to a *permanent* pool).
- 12) Consider positioning your swim spa out of or adequately protecting it from the wind. Just as people can get cold on cool/windy days, so can your swim spa. Windy environments can significantly increase operating costs.



**Figure 3 – A Crane is a Common Delivery Arrangement for Swim Spas**

## Electrical Specifications

**Important** – Qualified and licensed electricians must perform all electrical hookups. The following specifications must be followed in order to ensure proper performance and safety.

**⚠ WARNING:** Starting an incorrectly wired swim spa could cause severe damage to the mechanical equipment or even bodily harm. Have your licensed electrician verify GFCI (or RCD) wiring with the diagrams on pages xx-xx prior to starting the swim spa or call the technical support line at 727.573.9611.

**⚠ Caution:** Failure to abide by specifications listed may result in damage to the equipment and will void the warranty. All swim spas must be wired with the appropriately sized wiring. Failure to do so will cause equipment damage and will not be covered under your warranty. All swim spas must be over current protected with a built-in GFCI (or RCD) in the service panel.

Model	Service 1 control (controller, spa panel)	Service 2 control (controller, spa panel)	Volts/ Frequency VAC/HZ	GFCI/RCD Required in AMPS Service1/ Service2	Wire size required Service1/ Service 2
SE18 (2030)	Power unit PLCFA(1244) Panel PL-HHR	VS500Z/ MVP260	240/120/60	40(Siemens)/ 40	4 Wire #8 / 4 Wire #8
SE18 (2030)	Power unit PLCFA(1244) Panel PL-HHR	VS500Z/ MVP260	240/120/60	50(Siemens)	4 Wire #6
SE18-EX (2030-EX)	Power unit PLCFA(1245) Panel PL-HHR	GS500Z/ MVP260	1x220- 240/50	1x32/ 1x32	3x4mm <sup>2</sup> / 3x4mm <sup>2</sup> or 5x2.5mm <sup>2</sup>
SE18-EX (2030-EX)	Power unit PLCFA(1245) Panel PL-HHR	GS500Z/ MVP260	1x 220- 240/50	1x32	3x4mm <sup>2</sup>

**Table 1 – US, Canada/Export (in Gray) Electrical Specification**

**NOTE:** The Service 1 and the Service 2 will need to be wired independently.

Use Siemens GFCI only for Service 1(US/Canada)

**⚠ WARNING:** Disconnect electrical power before servicing. Before obtaining access to terminals, all supply circuits must be disconnected.

**⚠ WARNING:** Test the GFCI (or RCD) before each use.



Our swim spas are certified by Intertek Testing, SNAa Ltd. Ontario, Canada to CSA-C22.2 No. 218.1-M89 and ANSI/UL 1563 standards.



Parts with extra low voltage not exceeding 12v must be inaccessible to a person in the swim spa. Earthed appliances must be permanently connected to fixed wiring. Parts incorporating electrical components, except remote control devices, must be located or fixed so that they cannot fall into the swim spa.

Means for disconnection must be used in fixed wiring in accordance with wiring rules.

**Important** – To allow the 240V GFCI to function properly, connect the white Neutral wire from the swim spa to the Neutral terminal on the GFCI breaker, not the Neutral bus in the GFCI breaker box. An improperly connected Neutral causes the GFCI breaker to trip.

## Wiring Diagrams

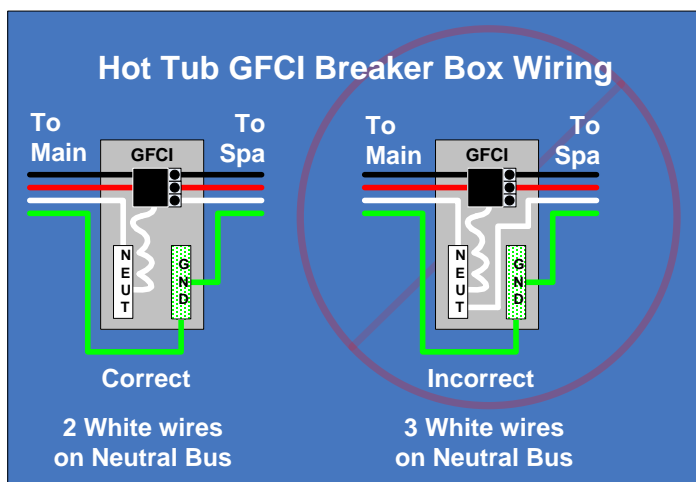
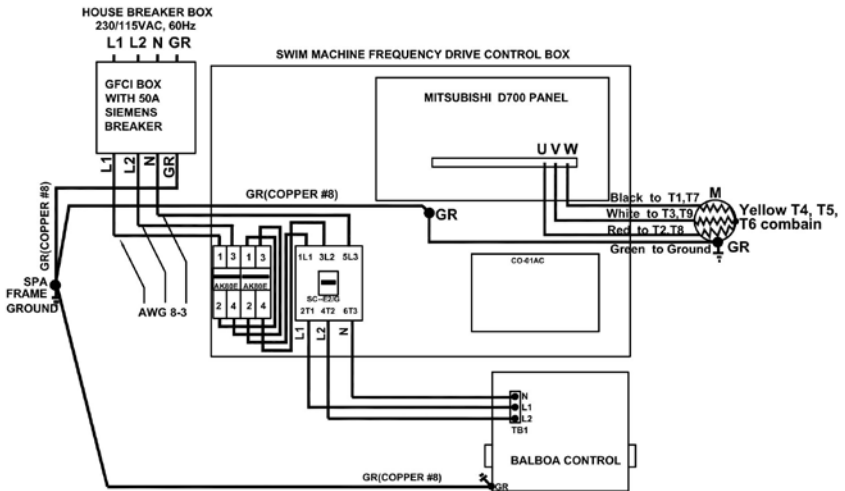
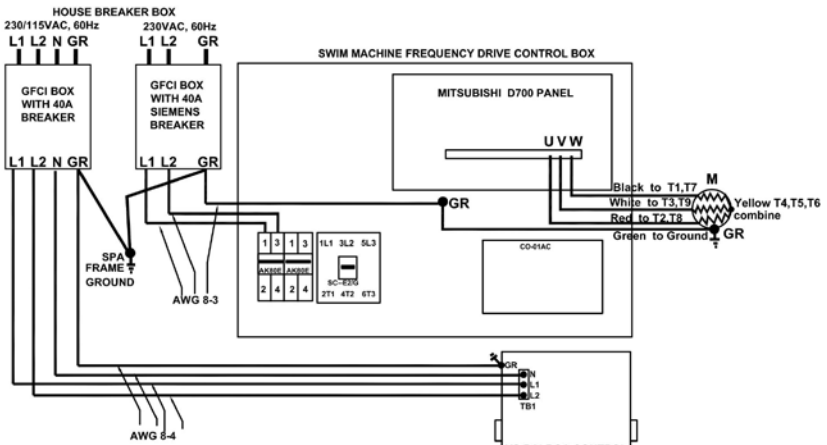

Figure 4 – 240V GFCI Wiring



SWIMMER EDGE SE18 (US, CANADA). WIRING DIAGRAM FOR ONE POWER SERVICE (50A SIEMENS GFCI).



SWIMMER EDGE SE18(US, CANADA). WIRING DIAGRAM FOR TWO POWER SERVICES (40A SIEMENS GFCI, 40A GFCI).

Figure 11A – Electrical Service for US/Canada.

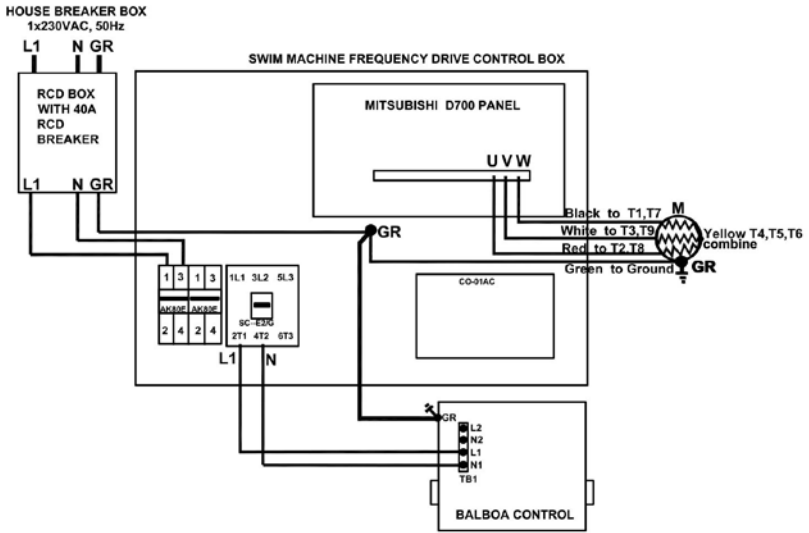

SWIMMER EDGE SE18 (EXPORT). WIRING DIAGRAM FOR ONE POWER SERVICE. (40A RCD).

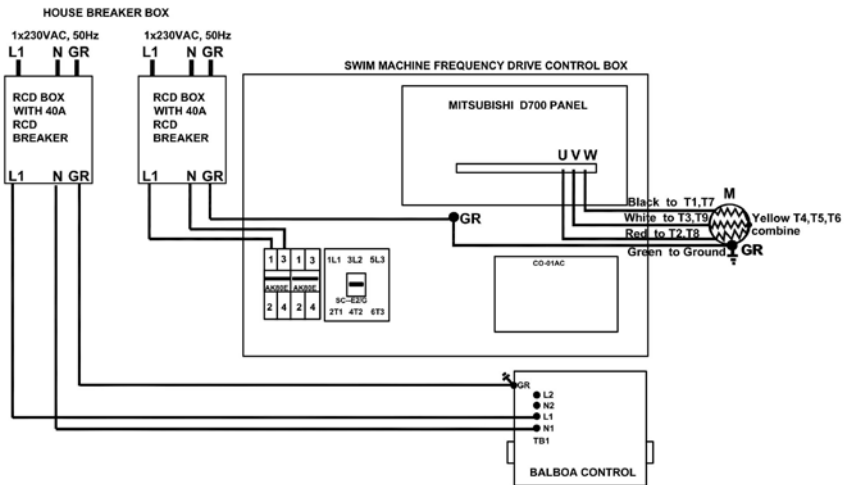

SWIMMER EDGE SE18 (EXPORT). WIRING DIAGRAM FOR TWO POWER SERVICES (2x40A RCD).

Figure 11B – Electrical Service for Export.

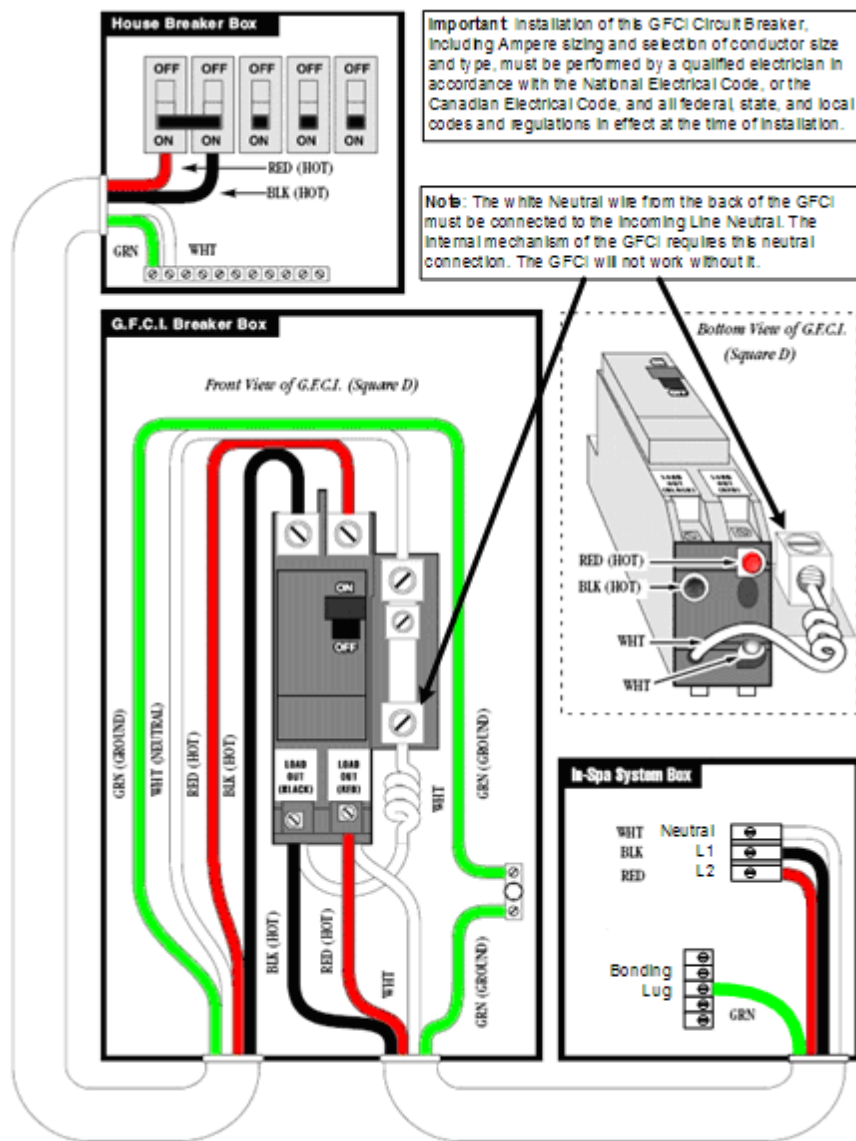
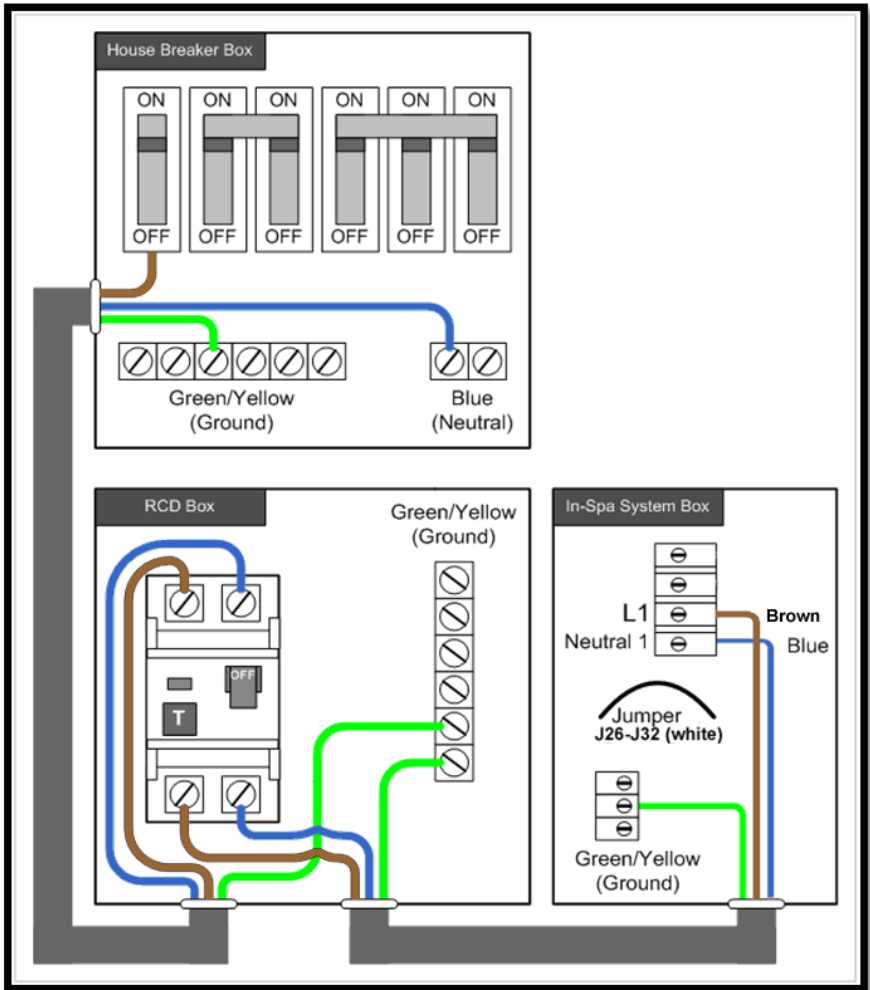

Figure 5 – US/Canada GFCI Diagram



**Figure 6 – Export 1x32A**

All wiring is 3x4 mm<sup>2</sup>, solid copper  
See wire size chart on page 10.

# U.S./Can. Wiring – Swim Side

PVS500Z –PN 55940  
240VAC ONLY DEVICES

CONTROL PANEL  
TO J1

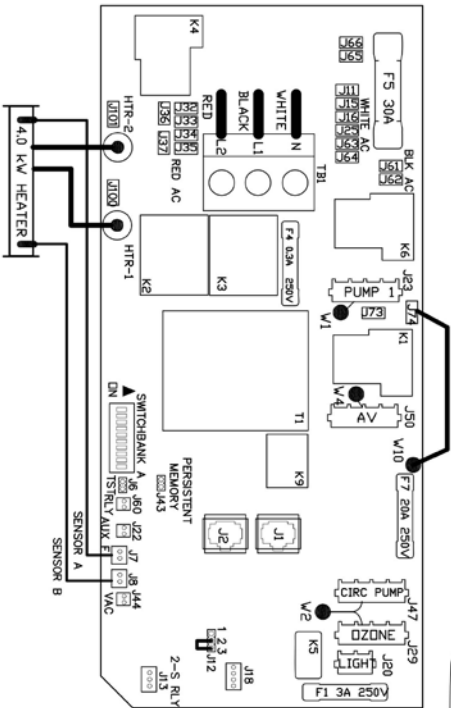

A DISCONNECTING MEANS MUST BE INSTALLED WITHIN SIGHT FROM THE EQUIPMENT AND AT LEAST 5 FEET (1.5 M) FROM THE INSIDE WALLS OF THE POOL, SPA, OR HOT TUB.  
USE COPPER CONDUCTORS ONLY.  
EMPLOYER UNIFORMENT DIE CONDUCTORS DIE CUIVRE.  
#6 AVG MIN. WIRE= 90°  
FOR SUPPLY CONNECTIONS.  
USE CONDUCTORS SIZED ON THE BASIS OF 60°C AMPACITY BUT RATED MINIMUM OF 90°C.  
USE EARTH GROUND CONNECTIONS AS INDICATED INSIDE THE SYSTEM ENCLOSURE

TORQUE RANGE FOR MAIN TERMINAL BLOCK: 27-30 IN. LBS.  
TORQUE RANGE FOR HEATER CONNECTIONS: 30 TO 35 IN. LBS.

TOTAL OUTPUT AMP DRAW NOT TO EXCEED MAX INPUT RATING OF SPA. CIRC PUMP IS AN OPTIONAL DEVICE. SEE CIRC PUMP BEHAVIOR TABLE.

SWITCHBANK A OFF (DOWN)		SWITCHBANK A ON (UP)	
TEST MODE OFF	▲ A1	TEST MODE ON	▲ A1
UNUSED/JET/TEMP/LIGHT	▲ A2	JET/LIGHT/DOWN/UP	▲ A2
DIG OR LT DUPL EX PANEL	▲ A3	MINI PANEL	▲ A3
AUX FREEZE (MUST BE OFF)	▲ A4	AUX FREEZE (MUST BE OFF)	▲ A4
SEE CIRC PUMP BEHAVIOR	▲ A5	SEE CIRC PUMP BEHAVIOR	▲ A5
60-HZ	▲ A6	50-HZ	▲ A6
STD/EN/SLEEP MODE	▲ A7	STANDARD MODE ONLY	▲ A7
DEGREGS F	▲ A8	DEGREGS C	▲ A8
SEE CIRC PUMP BEHAVIOR	▲ A9	SEE CIRC PUMP BEHAVIOR	▲ A9
HIGH AMP MODE	▲ A10	LDW AMP MODE	▲ A10

ALL UNUSED SWITCHES SHOULD BE OFF

CIRC PUMP BEHAVIOR	A5	A9	PUMP 1 SPEEDS
NO CIRC PUMP	OFF	OFF	2-SPEED
CIRC ACTS LIKE PUMP 1 LDW	DN	OFF	1-SPEED
24 HR WITH 3F SHUT-OFF	OFF	DN	1-SPEED
24 HR WITH 3F SHUT-OFF	DN	DN	2-SPEED

240V ONLY DEVICES						
LOCATION/ DEVICE	VOLTS	AMPS	FROM	TO		
J23	2 SPD	240W	W1	RED AC		
J47	CIRC PUMP	240W	W2	RED AC		
J50	AV	240W	W4	RED AC		
J29	OZONE	240W	W2	RED AC		
J20	LIGHT	12V				
HTR	HEATER	240W	HTR TERM	HTR 1/2		

GS500Z — PN 54509-01

CONTROL PANEL  
TO J1

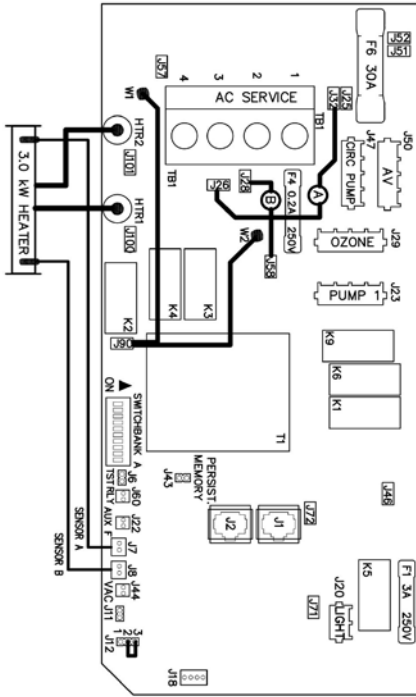

USE COPPER CONDUCTORS ONLY.  
EMPLÖSER UNDIQUUMENT 1  
DES CONDUCTEURS DE CUivre.  
#8 AWG MIN. WIRE= 90  
FOR SUPPLY CONNECTIONS,  
USE CONDUCTORS SIZED ON THE  
BASIS OF 60C AMPACITY BUT  
RATED MINIMUM OF 90C.  
GROUND — TERRE — ERDE  
GELB/GRÜN — JAUNE/VERT  
YELLOW/GREEN

TORQUE RANGE  
FOR HEATER  
CONNECTIONS:  
30 TO 35 IN. LBS.  
(34.5-40.3 kg cm)  
TORQUE RANGE FOR  
MAIN TERMINAL BLOCK (TB1):  
21.1-30 IN. LBS.  
(21.1-34.5 kg cm)

TEST MODE OFF	TEST MODE ON
UNUSED/LET/TEMP/L1	A1
DDUP/LTDUP PANEL	A2
MUST BE OFF	A3
SEE CIRC PUMP BEHAVIOR	A4
60 Hz	A5
STD/EN/SLP MODES	A6
DEGREES F	A7
SEE CIRC PUMP BEHAVIOR	A8
HIGH AMP MODE	A9
	A10

ALL UNUSED SWITCHES SHOULD BE OFF

PUMP BEHAVIOR	A5	A9	PUMP 1 SPEED
NO CIRC PUMP	OFF	OFF	2 SPEEDS
FILTERS/BALLS ONLY	DN	OFF	1 SPEED
24HR 3F SHUT-OFF	OFF	DN	1 SPEED
24HR 3F SHUT-OFF	DN	DN	2 SPEEDS

POWER CONNECTION	AC SERVICE	WIRE (A) (WHT)	WIRE (B) (BLU)	WIRE (C) (YEL)	WIRE (D) (BLK)
L1 to 3, N1 to 4	230V 1p / 1x16A-32A	J26 TO J32	J58 TO J28	TO J25*	TO J28*
L1 to 3, N1 to 4, L2 to 1, N2 to 2	230V 1p / 2x16A	REMOVE	J58 TO J28	TO J25*	TO J28*
N to 4, L1 to 3, L2 to 2, L3 to 1	400V 3p / 3x16A	REMOVE	REMOVE	REMOVE	TO J28*

\* WIRE ORIGINATES FROM AN OPTIONAL EXPANDER BOARD  
\*\* WIRE WITH ORIGINAL EXPANDER BOARD

LOCATION	DEVICE
J23	NETZSTROMVERSORGUNG 2-GEschw.-PUMPE 1 ALTERNATION PUMPE 1 A 2 WITESSES 2-SPEED PUMP 1
J47	KREISLAUF PUMPE PUMPE DE CIRCULATION CIRC PUMP
J50	AV
J29	OZONGENERATOR GENERATOR OZONE OZONE GENERATOR
J20	BELEUCHTUNG ECLAIRAGE BAIN HYDRO SPA LIGHT

# PGS510SZ - PN 55942-01

CONTROL PANEL TO J1

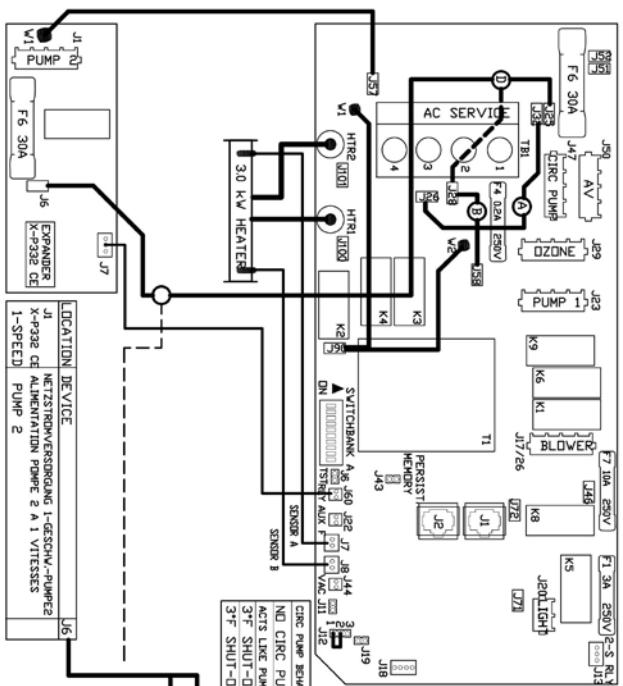

LOCATION	DEVICE
J1	NETZSTROMVERSORGUNG 1-GE-SCHW.-PUMPE
J2	EXPANDER K-P332 CE
J3	NETZSTROMVERSORGUNG 2-GE-SCHW.-PUMPE 1
J4	KREISLAUF PUMPE
J5	VENTILATEUR SPURDELGEBLÄSE BLOWER
J6	AV
J7	DZDNGENERATOR GENERATOR/DZDNE GENERATOR
J8	ECLAIRAGE BAIN HYDRO SPA LIGHT

NO	CIRCUIT PUMP	DN	DN	DN	DN	DN	DN	DN	DN
1	NO CIRCUIT PUMP	DN	DN	DN	DN	DN	DN	DN	DN
2	AUX LINE PUMP LOW	DN	DN	DN	DN	DN	DN	DN	DN
3	3-F SHUT-OFF	DN	DN	DN	DN	DN	DN	DN	DN
4	3-F SHUT-OFF	DN	DN	DN	DN	DN	DN	DN	DN

TABLE 1	WIRE	WIRE	WIRE	WIRE	WIRE	WIRE	WIRE	WIRE	WIRE
AC SERVICE	230V 1P / 2x16GA-32A	REMOVE	230V 1P / 2x16GA	REMOVE	400V 3P / 2x16GA	REMOVE	AC SERVICE	230V 1P / 2x16GA-32A	REMOVE
1 HIGH-SPEED PUMP OR BLOWER	REMOVE	REMOVE	REMOVE	REMOVE	REMOVE	REMOVE	REMOVE	REMOVE	REMOVE
2 HIGH-SPEED PUMP OR BLOWER	REMOVE	REMOVE	REMOVE	REMOVE	REMOVE	REMOVE	REMOVE	REMOVE	REMOVE
3 HIGH-SPEED PUMPS OR 2 HIGH-SPEED PUMPS AND BLOWER	REMOVE	REMOVE	REMOVE	REMOVE	REMOVE	REMOVE	REMOVE	REMOVE	REMOVE

TEST MODE OFF	TEST MODE ON
SEE TABLE 1	SEE TABLE 1
EXT RELAY BOARD DISABLED	EXT RELAY BOARD ENABLED
AUX FREEZE MUST BE OFF	AUX FREEZE MUST BE OFF
SEE CIRCUIT PUMP TABLE	SEE CIRCUIT PUMP TABLE
60 Hz	50 Hz
J17/26 BLOWER DISABLED	J17/26 BLOWER ENABLED
DEGREES F	DEGREES C
SEE CIRCUIT PUMP TABLE	SEE CIRCUIT PUMP TABLE
SEE TABLE 1	SEE TABLE 1

ALL UNUSED SWITCHES SHOULD BE OFF

SWITCHBANK A OFF (DOWN) SWITCHBANK A ON (UP)

USE COPPER CONDUCTORS ONLY.  
 EXP-OTHER UNDERMENT CULIVER.  
 #6 AVE MIN WIRE= 90°  
 FOR SUPPLY CONNECTIONS.  
 USE CONDUCTORS SIZED ON THE BASIS OF 60% AMPACITY BUT RATED MINIMUM OF 30°C.  
 GELBLAU/GRÜN - JAUNE/VERT  
 YELLOW/GREEN

TORQUE RANGE FOR HEATER CONNECTIONS:  
 90 LB IN. LBS  
 27-30 LB IN. LBS  
 TORQUE RANGE FOR MAIN TERMINAL BLOCK (T1B1):  
 27-30 LB IN. LBS  
 (211-245 kg cm)

TORQUE RANGE FOR HEATER CONNECTIONS:  
 90 LB IN. LBS  
 27-30 LB IN. LBS  
 TORQUE RANGE FOR MAIN TERMINAL BLOCK (T1B1):  
 27-30 LB IN. LBS  
 (211-245 kg cm)

# Startup

**Important** – Read these step-by-step startup procedures before starting your swim spa. Failure to follow any of these steps listed may result in damage to the equipment and may void your warranty.

**Note:** If you are unsure of any of the above startup procedures, please call our customer care center at 727.573.9611. For best results, read each step in its entirety before proceeding.

**⚠ Caution:** Running the swim spa pump dry (without water running through it) can cause IMMEDIATE damage and will void the warranty! Be sure that the swim spa is installed properly in accordance with the instructions in this manual.

Refer to the following picture for an explanation of your swim spa's controls, components, and technical terms. Note that not all models have all features and components. See also pages 52-59 for more information.



## Before Adding Water

Before adding water, go through these simple steps now to prevent common issues when setting up your swim spa for the first time. Verify that the following have all been rechecked.

1. Turn off all power to the swim spa at the main breaker panel.
2. Open the side panels to access the internal components.
3. Check that all slide valves are opened (T-handles pulled out) to the heater and all pumps.
4. Check that there are no obvious signs of loose wires or broken pipes.

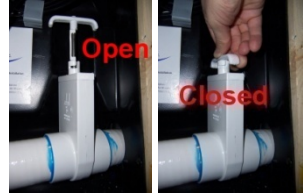

Figure 18 - Valve Open/Closed

5. Check that the two heater unions are hand tight.

**⚠ Caution:** Do not use a wrench. Overtightening may cause damage to unions and gaskets, which will not be covered under warranty.



Figure 19 - Unions Tight

6. Check that the unions on all pumps are tight.
7. Clean out any foreign debris from within the service access area or inside of the swim spa itself.
8. With the drain open and filters removed, thoroughly rinse out the swim spa with warm water until the drained water runs clear. Run water through the filtration canister and jet lines to remove any incidental dust, dirt, and debris that may have accumulated during shipment or installation. Drain all water completely.
9. Make sure that the swim spa drain valve is closed and the cap is on tight (see page 49).
10. Install the filter(s) in the filtration canister.
11. Check that all of the swim spa jets are open (turned full counter-clockwise).
12. Now is the best time to clean and polish the surfaces of your swim spa (see page 44).

## Filling Your Swim spa

Now it's time to fill your swim spa with water. Do not turn on the electricity yet until the swim spa is completely filled. To properly fill your swim spa:

1. Make sure that the filters (in the filtration canister) are gently screwed into place. Turn them clockwise until they stop being careful not to over-tighten them (this avoids cracking the filter).
2. Connect a standard garden hose to a faucet with regular cold tap water (not softened water or hot water).



**Figure 20 – Filtration Canister**

- ⚠ Caution:** The water from your hot water tank should not be used to fill the swim spa.
3. Put the pre-filter (if equipped\*) on the other end of the hose, point the pre-filter into a suitable drain, turn on the water, and allow any sediment to be flushed down the drain. Once the water stream runs clear, turn off the hose.
  4. Put the pre-filter (if equipped) into the filtration canister and turn on the hose.
  5. **Fill slowly.** If too much water pressure is used, foaming water can force air into the pipes and cause startup problems.

**Important:** To assure that the pump is properly primed, **fill the swim spa through the filter area only.**

6. Fill the swim spa until the water level is about 1" above all jets (or about ½" below the pillow). Do not over fill.

**Note:** Every person entering a swim spa displaces a given volume of water, so adjust water level to the number of people regularly using the swim spa. Turn off the hose and check again for any small leaks.

## Operational Checks: Swimmer's Edge 18 (Hydraulic System)

### Starting the Hydraulic System

- ⚠ Caution:** Turn off all power to the swim spa at the main breaker panel.
1. Check the sight glass located on the side of the tank. A small amount of fluid is shipped in the tank from the factory and should be visible in the sight glass.
  2. Remove the fill cap lid located on the top of the tank. Pour fluid in the tank until the sight glass is completely filled. (NOTE: USE ONLY THE FLUID PROVIDED BY PREMIUM LEISURE). Fluid will be blue. Once full, tighten the fill cap.

---

\* Pre-filters are available by calling 877.530.PARTS

3. Turn the power on at the main breaker. The LED display will show two red lights. Using the handheld remote control (see page 40), press the ON/OFF button. The system will come on and the LED readout will automatically go to 50. Let the system run for 2-3 minutes to pressurize itself. (NOTE: If the system does not turn on, check the LED readout to see if it reads "LOW OIL." If so, follow the instructions for Low Oil Shut Off (below).
4. Shut the system off and check for any leaks that may have occurred during shipment. The fluid level should have dropped as it pressurized the hoses.
5. Fill the tank until the fluid reaches 260 in the sight glass. Your system is now ready to restart. We recommend maintaining your fluid level at 260 in the sight glass. Periodically check your fluid level.
6. Using the handheld remote control, turn your system on and increase the flow to 100-150 and let it run for 5-10 minutes.

NOTE: There is an automatic shut off built in to the Swimmer's Edge 18 swim spa. The hydraulic system will run for 30 minutes and shut off. If this happens, simply turn it back on using the handheld remote control.

### **Low Oil Shut Off**

---

The low oil shut off valve is located on the top of the aluminum tank, next to the fill cap. If your system is low on oil, the LED digital readout will indicate "LOW OIL." You must turn the system off at the breaker and wait 5 minutes before turning it back on. This will reset the program. Fill the tank until the fluid reaches 200 in the sight glass. Turn the power back on at the breaker.

### **Bleeding Air from the Pressure Line**

---

When you turn your power unit on and the flow head (water current) does not come on, you must bleed your pressure system (yellow line). With the system running, slowly loosen the yellow pressure hose fitting. Air will escape. Once all the air has escaped, the flow head will spin and the current will resume.

### **Startup and Maintenance**

---

The Swimmer's Edge 18 is full and ready for swimming when the water level reaches ½ inch to 1 inch above the flow head where the water current is produced. (About level with the metal grab rail).

NOTE: A low water level can result in filtration and heating problems. Regularly "top off" your Swimmer's Edge 18 swim spa with a nearby garden hose. A high water level could cause excess overspill and splash out.

Once your Swimmer's Edge 18 is full and all connections are made, the water quality system can be started.

Set your filtration mode to your desired setting (see page 32) and set your water temperature (see page 31) to your desired setting (we recommend 80 degrees F, or 27 C, for swimming). It could take 36 to 48 hours to reach your desired

temperature the first time you fill your swim spa.

Note: The hydraulic hoses should be changed every year.

## Balancing the Swim Spa Water

Once your swim spa reaches 95°F, use our *Bromine Test Strips* (not included) and add the necessary chemicals (not included) to stabilize your water chemistry. Turn Pump 1 on high speed before starting your tests to distribute chemicals evenly. Wait 5 minutes between measurements to allow added chemicals to mix thoroughly.

**Important:** Test the condition of your water in the following order:

1. **Total Alkalinity** (80-120 ppm) – Use our *Alkalinity Increaser* to raise total alkalinity and *Alkalinity Decreaser* to lower it. Low total alkalinity has little buffering capacity making the pH erratic. High total alkalinity has too much buffering capacity making the pH difficult to change.
2. **pH** (7.2-7.8) – Use *Spa Up* to raise the pH level and *Spa Down* to lower it.

 **Caution:** A pH lower than 7.2 can harm the metal surfaces of your swim spa and irritate your eyes and skin. A pH higher than 7.8 can create calcium deposits (scaling) on the shell and equipment.

3. **Hardness** (150-400 ppm) – Add *Increase Calcium* until the proper level is achieved. Unfortunately, there is no practical way to lower the native water hardness other than using a different source of water when filling your swim spa. Low hardness causes equipment corrosion and water foaming.
4. **Sanitizer** (3.0-5.0 ppm) – Use our *Deluxe Bromine Kit* to add Bromine until the proper level is achieved. Neglected swim spa water can breed bacteria and algae causing bather discomfort, skin rashes, and/or irritation.

Test	Range
Total Alkalinity	80-120 ppm
pH	7.2-7.8
Calcium Hardness	150-400 ppm
Sanitizer	3.0-5.0 ppm

**Table 2 - Recommended Ranges for Balanced Water**

**Note:** Perform water balancing weekly and whenever you change water (or when the swim spa is first filled) to ensure proper water condition.

## Draining Your Swimmer's Edge 18

We recommend draining your water every 6-12 months.

1. When draining the dual zone swim spa always drain the spa side before the swim side.
2. Locate nearest drain facility (laundry tub, floor drain, lawn, shower, etc).
3. Turn off the breaker(s) to swim spa and disconnect electrical power to all equipment.

## Operational Checks:

**⚠ Caution:** Do not turn on any pump until your swim spa is properly filled with water. Running any pump without water in your swim spa can cause IMMEDIATE damage, which is not covered under warranty!

By now you have rechecked your unit's mechanical connections and filled it with water to the recommended level). Turn on power to the swim spa at the main breaker panel and test the operation of the electrical system. If you encounter a problem, please reference the troubleshooting guide on page 45.

1. Turn on the breaker and test the operation of the Ground-Fault Circuit Interrupter (or RCD) breaker by pushing the small button. This should automatically trip the swim spa's circuit breaker.

**⚠ DANGER:** If this breaker does not trip, immediately call your electrician. Do not use your swim spa!

Only if pushing this button successfully trips this circuit breaker should you reset this breaker and proceed to the next step.

2. Go to the topside control panel. The spa side of the unit first goes into a 6-minute Priming mode, indicated by "Pr" message. Water heating is disabled during priming. To exit Priming mode and begin normal swim spa operation, press "WARM" (or the up arrow) or "COOL" (or the down arrow).
3. Press the "JETS" button. You should hear pump 1 turn on, see water circulating, and see the Jets light illuminate on the panel.
4. Press the JETS button again. You should hear the pump turn on a higher speed.

**⚠ Caution:** If water is not flowing from the jets after 2 minutes, turn the power off at the main panel and bleed air from the system. Turn the power on again. Sometimes momentarily turning the pump off/on will help to prime. Do this only 4 times.

5. If the water is running smoothly through the lines, open the air control valve to the jets and you should see an increase in jet pressure. Check and adjust the water and airflow of every jet if necessary.

Each hydrotherapy jet in the spa side can be adjusted for massage intensity and directional flow. Turn the outer jet dial counterclockwise to increase the water volume and clockwise to turn it off. Pivot the angle of a jet to achieve an optimal massage.

An air mixture intensifies the level of your massage. Turn the air control valve counterclockwise to increase the air mixture and clockwise to turn it off.

To minimize heat loss, close the air control valve when the swim spa is not in use.

6. Press the JETS button a third time to turn off pump 1.

**Note:** The pump remains on if filtration or heat is needed.

7. Press the LIGHT button to turn on all lights. Verify that the LED light system is on. Press the LIGHT button multiple times to cycle through the many available color patterns. Press the LIGHT button again to turn off the LED light system.

## Water Balancing

**Note:** Perform water balancing weekly and whenever you change water (or when the swim spa is first filled) to ensure proper water condition.

Once your swim spa reaches 95°F, use our *Bromine Test Strips* (not included) and add the necessary chemicals (not included) to stabilize your water chemistry. Turn Pump 1 on high speed before starting your tests to distribute chemicals evenly. Wait 5 minutes between measurements to allow added chemicals to mix thoroughly.

**Important:** Test the condition of your water in the following order:

5. **Total Alkalinity** (80-120 ppm) – Use our *Alkalinity Increaser* to raise total alkalinity and *Alkalinity Decreaser* to lower it. Low total alkalinity has little buffering capacity making the pH erratic. High total alkalinity has too much buffering capacity making the pH difficult to change.
6. **pH** (7.2-7.8) – Use *Spa Up* to raise the pH level and *Spa Down* to lower it.  
 **Caution:** A pH lower than 7.2 can harm the metal surfaces of your swim spa and irritate your eyes and skin. A pH higher than 7.8 can create calcium deposits (scaling) on the shell and equipment.
7. **Hardness** (150-400 ppm) – Add *Increase Calcium* until the proper level is achieved. Unfortunately, there is no practical way to lower the native water hardness other than using a different source of water when filling your swim spa. Low hardness causes equipment corrosion and water foaming.
8. **Sanitizer** (3.0-5.0 ppm) – Use our *Deluxe Bromine Kit* to add Bromine until the proper level is achieved. Neglected swim spa water can breed bacteria and algae causing bather discomfort, skin rashes, and/or irritation.

Test	Range
Total Alkalinity	80-120 ppm
pH	7.2-7.8
Calcium Hardness	150-400 ppm
Sanitizer	3.0-5.0 ppm

**Table 2 - Recommended Ranges for Balanced Water**

# Topside Controls & Operation

S

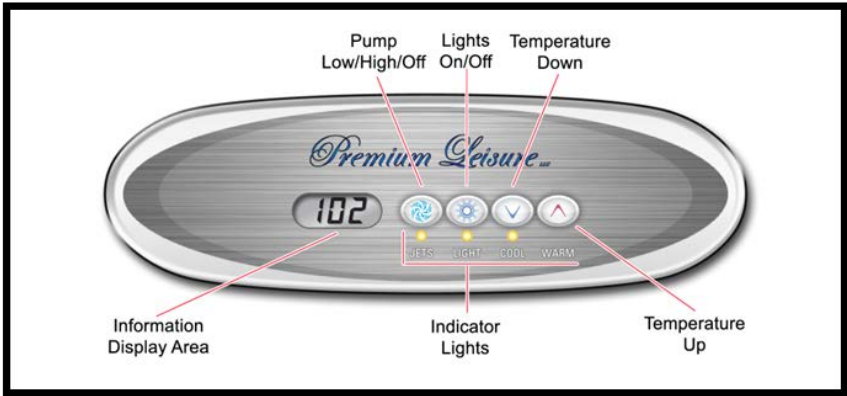

## MVP 260 Top Side Control Panel

US/Canada: used with controller VS500Z

Export: used with controller GS500Z

The topside control panel operates and programs your swim spa.

Basic button functions are described next.

When your swim spa is first actuated, it will go into Priming mode, indicated by "Pr". The Priming mode will last for less than 6 minutes (press "Warm" or "Cool" button to skip Priming Mode). And then the swim spa will begin to heat and maintain the water temperature in the Standard mode.

### Initial Start Up

When your swim spa is first actuated, it will go into Priming mode, indicated by "Pr." The priming mode will last for less than five minutes. Press "WARM" or "COOL" to skip Priming Mode and then the swim spa will begin to heat and maintain the temperature in "Standard Mode."

### Warm/Cool Buttons (Set Temperatures between 80°F - 104°F / 26°C - 40°C)

The startup temperature is set at 100°F/37°C. The last measured temperature is constantly displayed on the LCD and is current only when the pump has been running for at least two minutes. To **display** the set temperature, press the "WARM" or "COOL" button once. To **change** the set temperature, press the "WARM" or "COOL" button a second time before the LCD stops flashing. Each press of the "WARM" or "COOL" button will continue to raise/lower the set temperature. After three seconds, the LCD will stop flashing and display the current swim spa temperature.

### Jets Button

Press the “JETS” button once to activate the low speed of Pump 1. Press it a second time to activate the high speed of Pump 1. Press it a third time to turn off Pump 1. If left running, the high speed of Pump 1 automatically will turn off after 15 minutes and the low speed of Pump 1 automatically will turn off after 4 hours.

The low speed of Pump 1 may be active for at least two minutes every half hour to detect the swim spa temperature and then to heat to the set temperature if needed (depending on mode). When the low speed turns on automatically, it cannot be deactivated from the panel, however the high speed may be activated.

## Light

---

Press the “LIGHT” button once to turn on your swim spa lights. Press the LIGHT button multiple times to cycle through the many available color patterns. Press the LIGHT button again to turn off the LED light system. If left on, the lights automatically turn off after 4 hours.

## Mode

---

Your swim spa operating mode is changed by first pressing the “WARM” or “COLD” button, then pressing the “LIGHT” button.

- **Standard Mode** is programmed to constantly maintain the desired temperature. “*St*” will be displayed momentarily when you switch into standard mode.
- **Economy Mode** heats the spa to the set temperature *only* during filter cycles. “*Ec*” will display solid when temperature is not current and will alternate with temperature when temperature is current.
- **Sleep Mode** heats the swim spa to within 20°F/10°C of the set temperature only during filter cycles. “*SL*” will display solid when temperature is not current and will alternate with temperature when temperature is current.

## Preset Filter Cycles

---

The first filter cycle begins six minutes after the swim spa is energized. The second filter cycle begins 12 hours later. Filter duration is programmable for 2, 4, 6 or 8 hours – or for continuous filtration indicated by “*FC*”. The default filter time is two hours.

To program filter cycles, press “WARM” or “COOL” and then “JETS.” Press “WARM” or “COOL” again to adjust to your desired setting. Press “JETS” again to exit filter cycle programming.

The low speed of the 2-speed pump runs during filtration and the ozonator will be enabled.

## Smart Winter Mode

---



If the system (sensor located inside heater) detects ambient conditions below 44°F/6.7°C, it automatically enters the Smart Winter Mode for period of four minutes after it detects the swim spa temperature has risen to 45°F/7.2°C.

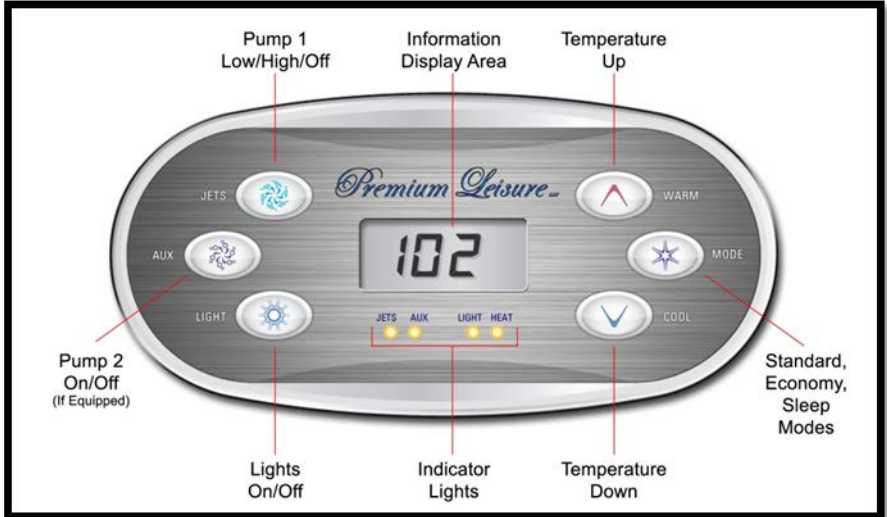

### VL 600S Top Side Control Panel

US/Canada: used with controller VS510SZ

Export: used with controller GS510SZ

The topside control panel operates and programs your swim spa. Basic button functions are described next.

When your swim spa is first time actuated, it will go into Priming mode, indicated by "Pr." The Priming mode will last for less than 6 minutes (press "Warm" or "Cool" button to skip Priming Mode. And then the swim spa will begin to heat and maintain the water temperature in the Standard mode.

#### Initial Start Up

When your swim spa is first actuated, it will go into Priming mode, indicated by "Pr." The priming mode will last for less than five minutes. Press "WARM" or "COOL" to skip Priming Mode and then the swim spa will begin to heat and maintain the temperature in "Standard Mode."

#### Warm/Cool Buttons (Set Temperatures between 80°F - 104°F / 26°C - 40°C)

The startup temperature is set at 100°F/37°C. The last measured temperature is constantly displayed on the LCD and is current only when the pump has been running for at least two minutes. To **display** the set temperature, press the

“WARM” or “COOL” button once. To **change** the set temperature, press the “WARM” or “COOL” button a second time before the LCD stops flashing. Each press of the “WARM” or “COOL” button will continue to raise/lower the set temperature. After three seconds, the LCD will stop flashing and display the current swim spa temperature.

## Jets Button

---

Press the “JETS” button once to activate the low speed of Pump 1. Press it a second time to activate the high speed of Pump 1. Press it a third time to turn off Pump 1. If left running, the high speed of Pump 1 automatically will turn off after 15 minutes and the low speed of Pump 1 automatically will turn off after 4 hours.

The low speed of Pump 1 runs when the “AUX” Pump 2 (if equipped) is on. It may also active for at least two minutes every half hour to detect the swim spa temperature and then to heat to the set temperature if needed (depending on mode). When the low speed turns on automatically, it cannot be deactivated from the panel, however the high speed may be activated.

## Aux Button

---

Press the “AUX” button once to turn on Pump 2 (if equipped). Press it a second time to turn off Pump 2. If left running, Pump 2 automatically will turn off after 15 minutes.

## Light

---

Press the “LIGHT” button once to turn on your swim spa lights. Press the LIGHT button multiple times to cycle through the many available color patterns. Press the LIGHT button again to turn off the LED light system. If left on, the lights automatically turn off after 4 hours.

## Mode

---

Your swim spa operating mode is changed by first pressing the “WARM” or “COLD” button, then pressing the “MODE” button.

- **Standard Mode** is programmed to constantly maintain the desired temperature. “*Std*” will be displayed momentarily when you switch into standard mode.
- **Economy Mode** heats the spa to the set temperature *only* during filter cycles. “*Ecn*” will display solid when temperature is not current and will alternate with temperature when temperature is current.
- **Sleep Mode** heats the swim spa to within 20°F/10°C of the set temperature *only* during filter cycles. “*SLP*” will display solid when temperature is not current and will alternate with temperature when temperature is current.

## Preset Filter Cycles

---

The first filter cycle begins six minutes after the swim spa is energized. The second filter cycle begins 12 hours later. Filter duration is programmable for 2, 4,

6 or 8 hours – or for continuous filtration indicated by “*FLC*.” The default filter time is two hours.

To program filter cycles, press “WARM” or “COOL” and then “JETS.” Press “WARM” or “COOL” again to adjust to your desired setting. Press “JETS” again to exit filter cycle programming.

The low speed of the 2-speed pump runs during filtration and the ozonator will be enabled.

### Smart Winter Mode



If the system (sensor located inside heater) detects ambient conditions below 44°F/6.7°C, it automatically enters the Smart Winter Mode for period of four minutes after it detects the swim spa temperature has risen to 45°F/7.2°C.

### Programming Summary

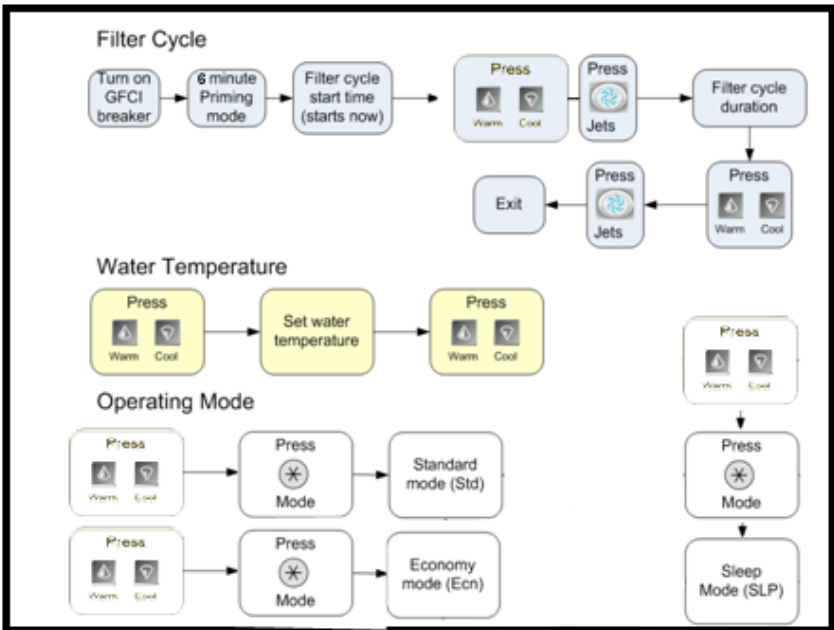

Figure 24 – VL600S Programming Summary

NOTE: FOR ALL SWIM SIDE EQUIPPED WITH MVP 260 PANEL:

- Follow the above steps to set the filter cycle and water temperature.
- To set the operating modes, follow the steps above *except* instead of pressing “Mode” – press “LIGHT.”

### Error Codes (All Spa Panels)

MESSAGE	MEANING	ACTION REQUIRED
<i>(none)</i>	No message on display. Power has been cut off to hot tub.	The control panel is disabled until power returns. Hot tub settings are preserved.
<b>OHH HH</b>	The hot tub has shut down from high heat detection. One of the sensors detected 118°F (48°C) at the heater.	Do not enter the water. Remove the cover and allow the water to cool. Once cool, push any button. If the hot tub does not reset, turn off the GFCI and call service.
<b>OHS OH</b>	The hot tub has overheated and shut down. One of the sensors detected that the hot tub water is 110°F (43°C).	Do not enter the water. Remove the cover and allow the water to cool. At 107°F (42°C), the hot tub resets automatically. If the hot tub does not reset, turn off the GFCI and call service.
<b>ICE IC</b>	Potential freeze condition detected (Ice)	No action required. The pump will automatically operate regardless of the hot tub status.
<b>SnA SA</b>	Sensor A is not working correctly. Hot tub is shut down.	Check the sensor "A" plug connection to circuit board. The problem may appear temporarily in an overheat situation and disappear when the heater cools. If the problem persists, contact service.
<b>SnB SB</b>	Sensor B is not working correctly. Hot tub is shut down.	Check the sensor "B" plug connection to circuit board. The problem may appear temporarily in an overheat situation and disappear when the heater cools. If the problem persists, contact service.
<b>SnS Sn</b>	Sensors are out of balance.	If this alternates with the temperature, it may be temporary. If the display shows only this message (periodically blinking), the hot tub is shut down. If the problem persists, contact service.

<b>MESSAGE</b>	<b>MEANING</b>	<b>ACTION REQUIRED</b>
<b>HFL</b> <b>HL</b>	A substantial difference between sensors was detected (possible flow problem).	Check water level in hot tub and add water if necessary. Be sure that slide-valves are open. Make sure the pump is primed and has power. If the problem persists, contact service.
<b>LF</b>	<i>Low Flow</i> – persistent problem. Displays after the fifth occurrence of the "HL" message within 24 hours. Heater shuts down but other hot tub functions run normally.	Heating ability of the hot tub will not reset automatically; press any button to reset.
<b>dr</b>	Inadequate water, poor flow, or air bubbles detected in the heater. Hot tub is shut down for 15 minutes.	Check the water level and add water if necessary. Be sure that slide-valves are open. Make sure the pump is primed and has power. Press any button to reset (automatically reset within 15 minutes). If the problem persists, contact service.
<b>drY</b> <b>dy</b>	Inadequate water detected in heater. Displays on third occurrence of "dr" message. Hot tub is shut down.	Check water level in hot tub. Add water if necessary. Be sure that slide-valves are open. Make sure the pump is primed and has power. Press any button to reset.
<b>Pr</b>	When the hot tub is first activated, it goes into Priming mode.	The Priming mode runs for up to four minutes and then the hot tub begins to heat and maintain the water temperature in Standard mode.
<b>-- F</b>	Temperature unknown	After the pump has been running for two minutes, the temperature will be displayed.
<b>-- C</b>	Temperature unknown	After the pump runs for two minutes, the temperature displays
<b>---</b>	Temperature not current	The hot tub is in either Economy or Sleep modes and the pump has not run for a while. To view the current temperature, switch to Standard mode or operate Jets 1 for at least one minute.
<b>SbY</b>	Hot tub is in standby mode	Press any button except Jets 1 to leave Standby mode.
<b>PHL</b>	pH is low	Add pH increaser (pH up)
<b>PHH</b>	pH is high	Add pH decreaser (pH down)
<b>SAL</b>	Sanitizer is low	Add sanitizer
<b>SAH</b>	Sanitizer is high	Remove hot tub cover and allow sanitizer to evaporate

<b>MESSAGE</b>	<b>MEANING</b>	<b>ACTION REQUIRED</b>
<b>drn</b>	Pump is on during Standby mode to assist in draining the water	Press Jets 1 to turn off pump once the water has drained out
<b>rtC</b>	Hardware failure	Contact customer service
<b>PSst</b>	Hardware failure	Contact customer service
<b>CrC</b>	Firmware install problem	Contact customer service if this message appears on more than one power up
<b>CFE</b>	Configuration error. Hot tub cannot start up	Contact customer service
<b>9FI</b>	Could not trip GFCI	Contact customer service and do not use the hot tub.
<b>StU</b>	Pump appears to be stuck on	Contact customer service and do not use the hot tub
<b>HOt</b>	Pump was stuck on the last time it was powered on	Contact customer service and do not use the hot tub

## Swimmer's Edge 18 - Swim Side (Turbine Propeller, All Units)

When you are ready to swim in the Swimmer's Edge 18 Swim Spa, press the "ON/OFF" button on the waterproof touchpad panel located on swim spa lip. Your digital readout will default to the No. 50. Increase to your desired swim speed by pushing the "FAST" arrow up button. A "220" readout is approximately 3 miles per hour and should provide most people with a comfortable workout. A "300+" readout is recommended for advanced swimmers. Decrease the speed of the unit by pressing the "SLOW" arrow down button.

The digital readout numbers range from 50-999. They do not represent anything specific, but rather they provide each swimmer a benchmark to enjoy the same swim experience every time.

Press the "ON/OFF" button a second time to turn off the propeller. If you do not turn the propeller off, it will automatically turn off after 30 minutes.



Figure 25 – Touchpad for Hydraulic Turbine Propeller

# Cover

Place the insulated cover on your swim spa. Keeping the cover in place anytime the swim spa is not in use reduces the heating time and minimizes operating costs. The time required for initial heat-up varies depending on the starting water temperature, ambient temperature, and the capacity of your swim spa.

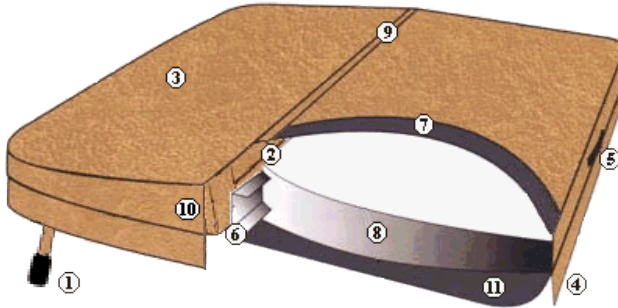

**Figure 28 - Cover Callouts**

- |                                |                                     |
|--------------------------------|-------------------------------------|
| 1. Lock-down tab               | 7. Heat-sealed insulation           |
| 2. Double-stitched seams       | 8. Chemical-resistant vapor barrier |
| 3. Marine-grade cover material | 9. Polystyrene seam stoppers        |
| 4. Edge overlap material       | 10. Reinforced edges                |
| 5. Grip handle                 | 11. Breathable underside material   |
| 6. Aluminum channel            |                                     |

Use the lock-down tabs to prevent access to the swim spa by children and to prevent the wind from lifting the cover off.



**Figure 29 -  
Lockdown Tabs**

Sitting, standing, and snow buildup on the cover will break the cover. Dragging it over rough surfaces will scuff or tear the fabric. Always lift by the handles or use the optional cover lift device.



**Figure 30 – Swim Spa Cover Sections for “18” Models**

## Frequently Asked Questions

### Who do I call for warranty information or service?

Call our customer care center between 8 a.m. and 5 p.m. EST Monday through Friday at 727.573.9611. Our representatives are eager to assist or you can get parts and information online at [www.HotTubParts.com](http://www.HotTubParts.com).

### How do I bleed air from my system?

When draining and refilling your swim spa, the pump may become air locked. Air-locked pumps stop water from flowing in your swim spa and is easily resolved by bleeding off the trapped air. To do this:

1. Turn off the GFCI breaker
2. Open the access panel below the topside control panel
3. Loosen a heater union until you hear the trapped air escape
4. Once water drips out in a continuous stream, hand tighten the union until the water stops leaking
5. Loosen the discharge union on Pump 2 (if equipped)
6. Once water drips out in a continuous stream, hand tighten the union until the water stops leaking
7. Turn on all pumps to make sure that there are no leaks
8. Put the access panels back on
9. Turn on the GFCI breaker

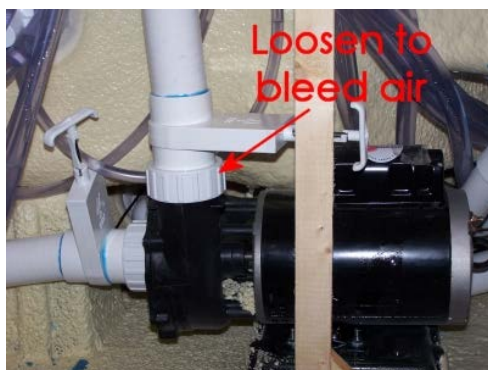

**Figure 31 - Bleeding Air**

### **What happens when my warranty expires?**

Premium Leisure will continue to provide service for your swim spa after your warranty has expired via our customer care center at 727.573.9611.

### **Where can I get more Chemicals or other accessories?**

Visit [www.hottubparts.com](http://www.hottubparts.com) or call 877.530.PARTS.

### **How should I clean my swim spa?**

Use non-sudsing cleaners and non-oily polishes (see page 50). Our Citra Bright Spray Cleaner and our Tub Rub cleaning pad quickly removes scum lines and helps restore your shell's original beauty. Rinse all filters, covers, pillows, and surfaces thoroughly with warm tap water. Our Filter Clean concentrated cleanser is a safe, effective way to clean and re-use your filters and our Jet Clean plumbing cleanser cleans the inside of all plumbing in your swim spa. Call 727.573.9611 to order these easy-to-use cleaning products.

### **How often should I drain my swim spa?**

You should drain and refill your swim spa every 6-12 months depending on usage. Every other time you drain and refill, you should also replace the filters and wipe down the swim spa (see pages 50).

### **How do I adjust my spa jets?**

Simply turn the jets counterclockwise to open and clockwise to close. Be careful not to overturn the jets, as damage can occur.

**⚠ Caution:** Do not turn off too many jets at the same time. This can create backflow and possible damage to your swim spa! Do not attempt to adjust the oval jets on the swim side of the unit.

### **Are the spa jets removable? Interchangeable? Replaceable?**

Most spa jets are made removable and adjustable for customized hydrotherapy.

Do not attempt to remove the oval jets on the swim side of the unit.

## T r o u b l e s h o o t i n g

If a problem arises, you can check this list for a quick solution. If this does not resolve your problem, please call our customer care center, at 727.573.9611. Additional information is also available at [www.PremiumLeisure.com](http://www.PremiumLeisure.com). You will need your serial number to access this site.

**Important** – Most problems can be quickly resolved by resetting the GFCI breaker. Try this first before proceeding.

### Spa Side Troubleshooting

PROBLEM	CAUSE	SOLUTION
<b>Breaker trips</b>	Wiring error	Load Neutral wire not connected to GFCI (connected to Neutral bus)
	Wrong GFCI	GFCI breaker is wrong size
	Ozonator wet	Remove tube from ozonator and allow 2 days to dry out
<b>Foamy water</b>	Soaps, skin oils, or undissolved sanitizer particles	Close the air control valves and allow filtration cycle to run Add defoamer Drain and clean your swim spa Clean or change filters Rinse all bathing suits before bathing
<b>Leak</b>	Loose connection	Check and hand-tighten unions at heater & pumps, or clamps on jets
	Drain open	Close drain valve or replace cap
<b>Light doesn't work</b>	LED burnt out	Replace bulb
	Loose wire	Check wiring harness to LED
	Loose plug	Reseat J20 plug on swim spa pack
<b>Low/no jet pressure</b>	Air lock	Bleed air from the system (page 43-44)
	Dirty filter	Check and clean or replace filter
	Closed jets	Open all jets by turning CCW
	Closed valves	Open all T-handle shutoff valves on heater and pumps
	ACV open	Close air control valves
<b>Moved my swim spa and now it doesn't work</b>	Low water	Fill swim spa 1" above all jets
	Wiring error at GFCI	Check Neutral wiring of GFCI (see diagrams on pages 12-22)
<b>Nothing works</b>	No power to swim spa	Reset circuit breakers on GFCI panel and main circuit breaker panel
	Breaker has tripped	Check and reset breaker. If problem persists, check for loose electrical connections. Check for Neutral wiring error at GFCI.

PROBLEM	CAUSE	SOLUTION
<b>Pump not running</b>	Fuse blown No power to swim spa	Check for blown fuses inside of spa pack. Reset circuit breakers on GFCI panel and main circuit breaker panel
<b>Water does not flow</b>	Air lock Closed jets ACV open	Bleed air from the system (page 43-44) Open all jets by turning counterclockwise Close air control valves
<b>Water too hot</b>	High set temperature High ambient temperature	Turn down set temperature on topside control panel Remove the cover
<b>Water will not heat</b>	Thermostat is set too low Air open Dirty filter Blown fuse Slide valve closed Cover off Swim spa in Economy mode	Check and reset to desired temperature Close air control valve Check and clean filter Check and replace fuse Check and open all valves Put the cover back on Press the Standby button and take out of Economy

### Common Error Codes:

MESSAGE	MEANING	ACTION REQUIRED
<i>(none)</i>	No message on display. Power has been cut off to swim spa.	The control panel is disabled until power returns. Swim spa settings are preserved.
<b>OHH HH</b>	The swim spa has shut down from high heat detection. One of the sensors detected 118°F (48°C) at the heater.	Do not enter the water. Remove the cover and allow the water to cool. Once cool, push any button. If the swim spa does not reset, turn off the GFCI and call service.
<b>OHS OH</b>	The swim spa has overheated and shut down. One of the sensors detected that the swim spa water is 110°F (43°C).	Do not enter the water. Remove the cover and allow the water to cool. At 107°F (42°C), the swim spa resets automatically. If the swim spa does not reset, turn off the GFCI and call service.
<b>ICE IC</b>	Potential freeze condition detected (Ice)	No action required. The pump will automatically operate regardless of the swim spa status.
<b>SnA SA</b>	Sensor A is not working correctly. Swim spa is shut down.	Check the sensor "A" plug connection to circuit board. The problem may appear temporarily in an overheat situation and disappear when the heater cools. If the problem persists, contact service.

MESSAGE	MEANING	ACTION REQUIRED
<b>SnB</b> <b>SB</b>	Sensor B is not working correctly. Swim spa is shut down.	Check the sensor "B" plug connection to circuit board. The problem may appear temporarily in an overheat situation and disappear when the heater cools. If the problem persists, contact service.
<b>SnS</b> <b>Sn</b>	Sensors are out of balance.	If this alternates with the temperature, it may be temporary. If the display shows only this message (periodically blinking), the swim spa is shut down .If the problem persists, contact service.
<b>HFL</b> <b>HL</b>	A substantial difference between sensors was detected (possible flow problem).	Check water level in swim spa and add water if necessary. Be sure that slide-valves are open. Make sure the pump is primed and has power. If the problem persists, contact service.
<b>LF</b>	<i>Low Flow</i> – persistent problem. Displays after the fifth occurrence of the "HL" message within 24 hours. Heater shuts down but other swim spa functions run normally.	Heating ability of the swim spa will not reset automatically; press any button to reset.
<b>dr</b>	Inadequate water, poor flow, or air bubbles detected in the heater. Swim spa is shut down for 15 minutes.	Check the water level and add water if necessary. Be sure that slide-valves are open. Make sure the pump is primed and has power. Press any button to reset (automatically reset within 15 minutes). If the problem persists, contact service.
<b>drY</b> <b>dy</b>	Inadequate water detected in heater. Displays on third occurrence of "dr" message. Swim spa is shut down.	Check water level in swim spa. Add water if necessary. Be sure that slide-valves are open. Make sure the pump is primed and has power. Press any button to reset.
<b>Pr</b>	When the swim spa is first activated, it goes into Priming mode.	The Priming mode runs for up to four minutes and then the swim spa begins to heat and maintain the water temperature in Standard mode.
<b>-- F</b>	Temperature unknown	After the pump has been running for two minutes, the temperature will be displayed.
<b>-- C</b>	Temperature unknown	After the pump runs for two minutes, the temperature displays

MESSAGE	MEANING	ACTION REQUIRED
- - -	Temperature not current	The swim spa is in either Economy or Sleep modes and the pump has not run for a while. To view the current temperature, switch to Standard mode or operate Jets 1 for at least one minute.
<b>SbY</b>	Swim spa is in standby mode	Press any button except Jets 1 to leave Standby mode.

## Maintenance and Care

**Important** – The warranty on your swim spa and equipment depends on proper sanitation (see page 50). In addition, the following maintenance procedures must be followed periodically.

### Cabinets

Your cabinet is made from a polymer that combines the durability of plastic with the beauty of simulated wood. To clean the cabinet, a mild soap and water solution easily removes residue.

### Cover

The 5-inch thick tapered cover on your swim spa is made from a weatherproof marine-grade vinyl. It comes in three pieces, two that fold in half and one small section for the middle. See page 42 for cover installation information. Your cover will last much longer if you heed the following suggestions:

- 1) Don't drag the cover on the ground; wearing of the vinyl could easily develop into a tear.
- 2) The insulating foam in your cover is not designed to hold the weight of a person or an animal.

**Important** – Cracked foam in the cover is not covered under warranty! Do not stand on it.

- 3) Occasionally clean the inside of your cover with our special All Purpose Cleaner rinsed with warm water. (Using soap or vinyl cleaners on the inside of your cover causes foamy water.) Call our order line at 727.573.9611 to order our All Purpose Cleaner.
- 4) Our special Vinyl Cover Cleaner applied to the outside of the cover and stitching once yearly will keep your cover looking better longer. Call our order line at 727.573.9611 to order our special Vinyl Cover Cleaner.
- 5) Do not lift the cover by the safety straps, they are made to secure the tub to the cabinet and may tear.

## Draining and Refilling

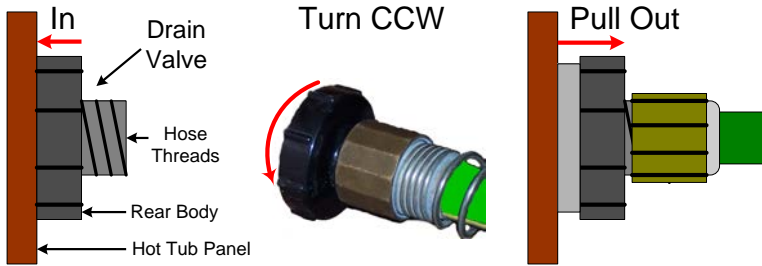

**Figure 32 - Drain Operation**

- 1) Turn off the GFCI breaker.
- 2) Remove swim spa cover and allow water to cool down.
- 3) Select a safe, suitable drainage area capable of safely assimilating approximately 2,000 gallons of water (7,571 liters) that may contain unsanitary contaminants and chemical residue that could cause harm to plants or grass.
- 4) Locate drain valve at base of the swim spa. Hold the rear body to prevent it from turning, then loosen and remove the front cap.
- 5) Attach a garden hose to the exposed threads and route the hose downhill to your drainage area.
- 6) Twist the drain fitting 1/3 turn counterclockwise to unlock the drain valve and pull it outward to open completely. The water will drain by gravitational flow.
- 7) After the swim spa drains, perform steps 3-5 in reverse order to close the drain prior to refilling swim spa.
- 8) Attach the garden hose to a thoroughly-flushed pre-filter (not included, rinsed of all residual sediment) and refill your swim spa through the filtration canister.
- 9) After refilling, turn on the GFCI breaker to the swim spa.

If the pump runs but no water flows, see page 43-44 to see how to bleed air from the system.

## Filters

The filters in your swim spa should be removed and cleaned every 2 weeks with our special Filter Clean concentrated cleanser and typically replaced every 4-6 months (depending upon use). You can clean your filters with the water pressure from the end of a garden hose then rinsed with warm water. This ensures that the water is being filtered properly.

**DO NOT USE BLEACH.** We recommend having replacement filters on hand that can be swapped between cleanings. Doing so enables you to quickly exchange the dirty filters with clean ones and immediately start your swim spa again. Call our order line at 727.573.9611 to order replacement filters and our special Filter Clean concentrated cleanser.

## Spa Jets

Remove and clean the spa jets as needed using our special our Jet Clean plumbing cleanser, water, and a cloth or soft-bristled brush. Call our order line at 727.573.9611 to order our special our Jet Clean plumbing cleanser.

## Light

Drain the swim spa and clean the light lens as needed using an optical cloth and an eyewear cleaning product specifically designed not to scratch optical surfaces. If the back side of the lens is also dirty remove the rear panel, remove the light from the holder, and clean in this same manner.

## Pillows

Remove and clean the headrest pillows as needed using our Citra Bright Spray Cleaner and our Tub Rub cleaning pad and rinsed thoroughly with warm water. Call our order line at 727.573.9611 to order our Citra Bright Spray Cleaner and our Tub Rub cleaning pad.

## Sanitation

Sanitation level is influenced by two factors:

1. Filter Cycle (filtration) time
2. How much you use your swim spa each week

If your water chemistry and water clarity are all proper and your sanitation level is still too low/high, you can adjust the sanitation intensity up/down by adding more/less sanitizer a little at a time and testing the water again after two days.

## Shutdown / Winterizing



Your Premium Leisure swim spa is designed to operate year round. If you plan to leave your swim spa unused for long periods of time in severely cold weather, you should winterize your swim spa to avoid accidental freezing due to a power or equipment failure.

**We highly recommend that you have a swim spa professional winterize and restart your swim spa.**

**⚠ WARNING:** Damage from improperly winterizing or restarting your swim spa is not covered under your warranty. You can call our customer care center, at 727.573.9611 for recommended service organizations to assist you in properly winterizing your swim spa.

## Surface

The acrylic surface of your swim spa should be cleaned with our Citra Bright Spray Cleaner and our Tub Rub cleaning pad and thoroughly rinsed with warm (not cold) water before refilling. (See also page 44.) Call our order line at 727.573.9611 to order cleaners.

**⚠ WARNING:** NEVER use paint solvents, acids, acetone, benzene, lacquer thinner, toluene, xylene, or similar chemicals to clean your swim spa shell.

## Water Management

Our chemical water purification system is a perfect match for your swim spa.

Depending on usage, the water in your swim spa should be changed every 6-12 months. Upon each change of water it is a good practice to wipe down the swim spa.

If your water quality seems improper, increasing the time the swim spa filters the water (see page 32) may clear up your problem.

Below are some answers to common water chemistry questions.

<b>pH</b>	It is common to have pH fluctuations after adding chemicals to your swim spa or after a party. Let your jets run and give your water time to stabilize. 9 times out of 10, your pH will come back into the 7.2-7.8 range on its own.
<b>MILDEW on cover</b>	Mildew usually grows in the folds and seams of your cover and then drips into your swim spa water causing cloudiness and/or odor. Clean with our special Citra Bright Spray Cleaner and then rinse the inside of your cover with clean warm water.
<b>Foamy water</b>	Foam typically results from soap residue on your skin and hair, or laundry detergent residue on clothing. Take a soapless shower and rinse all clothing in warm water prior to bathing.
<b>CLEAR green or brown water</b>	Your "source water" most likely has dissolved heavy metals. When this is the case, order our special Metal Gon metal remover. Using a pre-filter can remove these contaminants before they get into your swim spa (see page 25).
<b>CLOUDY green water</b>	Algae can be resolved by adding a respected brand of algacide.
<b>CLOUDY white water</b>	Although a normal condition immediately after filling that dissipates after time, with stabilized water this is a visual indication that the total alkalinity or pH or both are at improper levels. Test your water weekly and maintain proper water chemistry (see page 30).
<b>ODOR and/or CLOUDY water</b>	If your water develops an odor and/or cloudiness, clean your cover and filters and try increasing the amount of time the swim spa filters per day by turning your filtration cycle time or duration up.
<b>HEAVY use</b>	After a period of heavy use, your swim spa may cloud. Shock your swim spa with 2 ounces of non chlorine shock and wait 36 hours.

# Specifications

## SWIMMER'S EDGE 18 (MODEL 2030)



Spa Spec	
Spa Model	2030/SE18
Spa Dimension	89"x213"x58"
Spa Dimension	226cm x 541cm x 147cm
Number Of Seats	3
Water Jets	18
Water Capacity (USG/L)	2350/8896
Dry Weight (LBS/KG)	2600/1179
Filled Weight (LBS/KG)	22165/10075
Electrical Rating (VAC/AMP/Hz)	230-240/1x40/60
GFCI (AMP)	50 (Siemens type)

Call-Outs				
Label	Part#	Description	Qty.	Notes
1	73199W	Nozzle wall fitting (Gr)	1	
1A	7818	Wall fitting (Gr)	2	
2D	240-1509DSG-8S, 218-5150,228-1558G	Luxe Glo Cluster storm jet, Directional, Compensator ring, Jet Body	8	
2R	240-1519DSG-8S, 218-5150,228-1558G	Luxe Glo Cluster storm jet, Pulsator, Compensator ring, Jet Body	0	
3D	240-2309DSG-8S, 718-6960,228-0308G	Luxe Glo Mini storm jet, Directional, Compensator ring, Jet Body	0	
3R	240-2329DSG-8S, 718-6960,228-0308G	Luxe Glo Mini storm jet, Twin roto, Compensator ring, Jet Body	0	
4D	240-8309DSG-8S, 218-4010,228-0408G	Luxe Glo Poly storm jet, Directional, Compensator ring, Jet Body	10	
4R	240-8319DSG-8S, 218-4010,228-0408G	Luxe Glo Poly storm jet, Rotational, Compensator ring, Jet Body	0	
5D	240-6109DSG-8S, 218-6680,228-0048G	Luxe Glo Power storm jet, Directional Compensator ring, Jet Body	0	
5M	240-6139DSG-8S, 218-6680,228-0048G	Luxe Glo Power storm jet, MassageCompensator ring, Jet Body	0	
6	25059-101-000, 25090-089-200	1" AIR Control Halo, GP/Sil/IGP with LED bezel	2	
7	25056-111-000, 25030-089-200	1 "on-off valve Halo, GP/Sil/IGP with LED bezel	1	
8	1234(Assy)	River Pool control panel	1	
9	640-3790SGA V	251GPM Super Hi-Flo 2.5" Suction (metal)	3	
10	1219S, 1310A, 1312A, 1315, 1316, 1317	Light Kit 5", LED contr-r, 6-LED spyder, 9-LED light, Cable Assy	3+1+3+3+ 2	
11	53999	Panel ML260 w overlay	1	
12	823690	Pillow tri-curve	1	
13	3034	Sunbed w. pillow	1	
14	510-9109DSG	100 Sq. Filter	1	
15	642-4729DKG-V	12"x12" Grate	14	
16	642-4709DKG-V	9"x9" Grate	6	
17	210-9309S-DSG	Standard Water Feature	2	
18	3126, 3129, 3130	1" FRST lens, nuts, o-rings	18	
19	Recess on shell	Cup Holder	1	
20	1234(Assy)	Flowhead swim machine ss 60/50Hz less grates	1	
21	1234(Assy)	Readout display	1	
22	1266, 1267, 1268	Drain-valve Assy. with adapters	1	
N/A	7136, 6022, 310-1740	2 Speed Motor; 8' Cord ; Wet end 1740;	1	
N/A	6167, 6024, 310-0800	Circulation pump	1	
N/A	55940	Balboa Pack VS500Z	1	
N/A	5071, 7399	Ozonator w/ Cord, Injector	1	
N/A	7068	Swim Spas Owner's Manual	1	
N/A	SS22A	Spa Cover	1	



<b>Spa Spec</b>	
Spa Model	2030-EXSE18-EX
Spa Dimension	89"x213"x58"
Spa Dimension	226cm x 541cm x 147cm
Number Of Seats	3
Water Jets	18
Water Capacity (USG/L)	2350/8896
Dry Weight (LBS/KG)	2600/1179
Filled Weight (LBS/KG)	22165/10075
Electrical Rating (VAC/AMP/HZ)	220-240/3x16/50
RCD (AMP)	IEE Req.

Call-Outs				
Label	Part#	Description	Qty.	Notes
1	73199W	Nozzle wall fitting (Gr)	1	
1A	7818	Wall fitting (Gr)	2	
2D	240-1509DSG-8S, 218-5150,228-1558G	Luxe Glo Cluster storm jet, Directional, Compensator ring, Jet Body	8	
2R	240-1519DSG-8S, 218-5150,228-1558G	Luxe Glo Cluster storm jet, Pulsator, Compensator ring, Jet Body	0	
3D	240-2309DSG-8S, 718-6960,228-0308G	Luxe Glo Mini storm jet, Directional, Compensator ring, Jet Body	0	
3R	240-2329DSG-8S, 718-6960,228-0308G	Luxe Glo Mini storm jet, Twin roto, Compensator ring, Jet Body	0	
4D	240-8309DSG-8S, 218-4010,228-0408G	Luxe Glo Poly storm jet, Directional, Compensator ring, Jet Body	10	
4R	240-8319DSG-8S, 218-4010,228-0408G	Luxe Glo Poly storm jet, Rotational, Compensator ring, Jet Body	0	
5D	240-6109DSG-8S, 218-6680,228-0048G	Luxe Glo Power storm jet, Directional Compensator ring, Jet Body	0	
5M	240-6139DSG-8S, 218-6680,228-0048G	Luxe Glo Power storm jet, MassageCompensator ring, Jet Body	0	
6	25059-101-000, 25090-089-200	1" AIR Control Halo, GP/Sil/GP with LED bezel	2	
7	25056-111-000, 25030-089-200	1 "on-off valve Halo, GP/Sil/GP with LED bezel	1	
8	1234(Assy)	River Pool control panel	1	
9	640-3790SGA V	251GPM Super Hi-Flo 2.5" Suction (metal)	3	
10	1219S, 1310A, 1312A, 1315, 1316, 1317	Light Kit 5", LED contr-r, 6-LED spyder, 9-LED light, Cable Assy	3+1+3+3+ 2	
11	53999	Panel ML260 w.overlay	1	
12	823890	Pillow tri-curve	1	
13	3034	Sunbed w. pillow	1	
14	510-9109DSG	100 Sq. Filter	1	
15	642-4729DKG-V	12"x12" Grate	14	
16	642-4709DKG-V	9"x9" Grate	6	
17	210-9309S-DSG	Standard Water Feature	2	
18	3126, 3129, 3130	1" FRST lens, nuts, o-rings	18	
19	Recess on shell	Cup Holder	1	
20	1234(Assy)	Flowhead swim machine ss 60/50Hz less grates	1	
21	1234(Assy)	Readout display	1	
22	1266, 1267, 1268	Drain-valve Assy. with adapters	1	
N/A	7189, 6022, 310-1750	2 Speed Motor; 8' Cord ; Wet end 1750;	1	
N/A	7794, 6024, 310-0800	Circulation pump	1	
N/A	54509-01	Balboa Pack GS500Z	1	
N/A	5071, 7399	Ozonator w/ Cord, Injector	1	
N/A	7088	Swim Spas Owner's Manual	1	
N/A	SS22A	Spa Cover	1	

# Warranty

## **Lifetime Swim Spa Structural Warranty**

Premium Leisure LLC warrants the swim spa shell structure against the loss of water through the fiberglass laminate of the shell caused by defects in materials and workmanship for as long as the original purchaser owns the swim spa. Contact manufacturer if you have any questions concerning warranty issues.

## **Five (5) Year – Swim Spa Surface Warranty**

Premium Leisure LLC Warrants the interior acrylic swim spa surface against blisters, cracks, or delaminating resulting from a defect in the acrylic surface material for a period of five (5) years from the date of purchase, based on the following formula: Suggested retail price divided by months covered (60), multiplied by months owned plus shipping = replacement cost.

## **Lifetime Manifold Plumbing Parts Warranty**

Premium Leisure LLC warrants the plumbing manifolds, fittings, and parts to be free of defects in materials or workmanship for as long as the original purchaser owns the swim spa.

## **Two (2) Year – Limited Swim Spa Equipment Warranty**

Premium Leisure LLC warrants the electrical equipment and components to be free of defects in materials and workmanship for a period of two (2) years on major swim spa components (electrical system, swim spa controls, motors) and two (2) years authorized field service on these items. Ninety (90) day (Parts ONLY) Limited Warranty on all optional accessory items (optional cabinets, fixtures, trim kits, skirts, CD & MP3 players, all other music and video devices, ozone, waterfall assembly, LED lighting, etc). All perishable, cosmetic or owner serviceable items, swim spa cover, light bulb, light lenses, fuses, headrests, cabinet, filters, cover-lift, swim spa drain, jet inserts, etc are warranted to be free of defects in materials and workmanship at the time of delivery. These items may be covered by a manufacturer's warranty, which may have a longer duration than this Limited Warranty. Premium Leisure LLC may serve as an agent in presenting claims under the manufacturers' warranties, but disclaims any liability there under. In the event Premium Leisure LLC provides parts to replace an alleged defective part under warranty owner will be billed for the cost thereof and credited, minus freight, upon both the defective part being returned to Premium Leisure LLC and the manufacturer of said part accepting warranty claim.

## **Warranty Performance**

In the event of a suspected defect, under the terms of this Limited Warranty, notify manufacturer. Use all reasonable means to protect the swim spa from further damage. A service representative will provide the technical labor only, to affect the repair subject to the terms and conditions contained in this Limited Warranty. The service representative may assess reasonable travel charges. Visits to simply diagnose, troubleshoot, or inspect problems are not covered under this Limited Warranty. If we determine that repairs are not feasible due to functional defect, we reserve the right to provide a replacement part or swim spa in lieu of repair. We will replace with a part of value equal to the original purchase. In such event, owner is responsible for expenses including removal, shipping, and re-installation of the existing or replacement hot tub. The replacement swim spa or part will carry the balance of the original swim spa's warranty, if any. Either party's waiver of any breach or failure to enforce any of the terms or conditions of the warranty shall not in any way affect, limit or waive such party's right at any time to enforce strict compliance with every term and condition thereof.

## **Limitations and Exclusions**

This Limited Warranty applies to swim spas sold after January 1, 2008. This Limited Warranty takes effect from the date the unit was originally purchased or six months from the date of manufacture whichever comes first. This Limited Warranty applies only to the Original Purchaser and terminates with any transfer of ownership. This Limited Warranty does not apply to a swim spa used for any commercial, rental, club purposes or for any swim spa used outside of the United States. The purchaser must establish the date of purchase by dated sales invoice of delivery receipt.

This Limited Warranty does not cover damage resulting from abuse, misuse, or neglect including any installation, operation, maintenance or use of the swim spa other than in accordance with the Owner's Manual of the swim spa. Damage caused by operation of the swim spa at water temperatures outside the range of 32 degrees F. and 120 degrees F., damage caused by dirty, clogged, or calcified filter cartridges, damage to the swim spa surface caused by improper use of chemicals or cleaning agents, allowing un-dissolved water sanitizing chemicals to lie on the surface, damage caused by improper pH balance or other improper water chemistry, damage caused by failure to provide even and sufficient support for the swim spa, are considered abuses and may invalidate this Limited Warranty. Damaged caused by repairs or alterations performed by anyone other than an authorized service representative is not covered. Failure caused by accidents, acts of God, nonstructural normal wear and tear, cosmetic blemishes and other causes beyond our control are excluded.

The warranty is in lieu of all other warranties, expressed or implied, including implied warranties of merchantability and fitness for a particular purpose. In no event shall manufacturer be liable for incidental or consequential damages.

## **DISCLAIMERS**

The swim spa owner is required to provide unencumbered access to the swim spa for any warranty repair or inspection. Manufacturer shall not be liable for loss of use of swim spa or other incidental or consequential costs, expenses or damages, which may include, but are not limited to water damage, or the removal of a permanent deck or other customer fixture. Under no circumstances shall we, or any of our representatives be held liable for injury to any person or damage to any property, however arising. This warranty gives you specific legal rights and you may have other rights. No service company, or other party is authorized to change, modify, or extend the terms of this Limited Warranty in any manner whatsoever. The jurisdiction and venue for any litigation arising with respect to the transaction evidenced by this warranty shall be the Circuit Court in and for Pinellas County, Florida and Buyer hereby agrees to such jurisdiction and venue.

# *Premium Leisure* LLC

6101 45<sup>th</sup> St. N.  
St. Petersburg, FL 33714  
727.573.9611

[www.PremiumLeisure.com](http://www.PremiumLeisure.com)