

Premium Leisure LLC

SWIM SPAS OWNER'S MANUAL



Premium Leisure, LLC
6101 45th St. N.
St. Petersburg, FL 33714
727.573.9611
www.PremiumLeisure.com

Part Number 7068M

Revised 03/2014

Owner's Information

Dealer:

Date Purchased: _____
Company: _____
Address: _____
Telephone: _____

Installer:

Date Installed: _____
Company: _____
Address: _____
Telephone: _____

Swim Spa:

Date Delivered: _____
Model: _____
Color: _____
Serial Number: _____

Your unique swim spa serial number is located on a data plate outside the cabinet at ground level. When calling for service, please have your serial number in hand.



Premium Leisure™ Swim Spas

Owner's Manual

Table of Contents

Introduction	2
Important Safety Information	3
Site Selection and Installation	8
Electrical Specifications.....	10
Electrical Services.....	12
Wiring Diagrams.....	15
Startup	24
Water Balancing.....	29
Topside Controls & Operation	30
Optional Audio and Docking station	46
Cover.....	47
Frequently Asked Questions	48
Troubleshooting	50
Maintenance and Care	52
Specifications	56
Notes.....	88

Important: Premium Leisure is dedicated to offering you the best in customer satisfaction and service. Be sure to read, complete, sign, and **send in the limited warranty card within 30 days of purchase or register online at <http://premiumleisure.com/owners.shtml>** to ensure you understand what you are entitled to in terms of service. If you have any questions, you can call our customer care center at 727.573.9611.

Printed in the U.S.A.

Version 2.0

Revised 03/2014

Part # 7068

Copyright © 2010, Premium Leisure LLC. All rights reserved. No portion of this manual may be reproduced in any manner without express written permission of Premium Leisure LLC. Premium Leisure™ Swim spas and Fitness Trainers are trademarks of Premium Leisure LLC. All other brands, product names, company names, trade names, trademarks, and service marks used are the property of their respective owners. Premium Leisure LLC may make product modifications and enhancements. Specifications may change without notice. International products may be configured differently to meet local electrical requirements. Dimensions are approximate. Patents pending.

Introduction

Your choice of a Premium Leisure™ brand swim spa from Premium Leisure LLC indicates that you are devoted to excellence. The management and staff appreciate your patronage and takes pride in the tradition of quality swim spas that our company represents.

To properly acquaint yourself with your swim spa, we suggest that you take time to read through this manual before hook up and operation. Doing so will familiarize you with important operating and safety procedures, thereby ensuring an enjoyable experience right from the start.

If you need any more information than this manual provides, feel free to visit our Web site at www.PremiumLeisure.com or call our customer care center, at 727.573.9611.

⚠ WARNING: This manual was written to ensure the proper use and installation of your swim spa. Any modifications to the procedures outlined in this manual may result in voiding your warranty.

This manual and its contents are subject to change without notice. Although we have prepared this manual as accurate as possible, we are not liable for errors or omissions; loss, injury, or damages caused by improper installation; or use of swim spa (improper or otherwise).

Your new swim spa is made with quality synthetic cabinet materials. Synthetic materials won't fade and are nearly invulnerable to mold and mildew. Where wood splits, cracks, and stains, synthetic materials stand in timeless perfection.



Figure 1 – Dual Zone 18

NO DIVING

DANGER: DIVING MY RESULT IN SERIOUS INJURY OR DEATH

Important Safety Information

IMPORTANT SAFETY INSTRUCTIONS SAVE THESE INSTRUCTIONS

Your physiological response to hot water depends on subjective factors such as age, health, pregnant women, temperature sensitivities, chemical sensitivities, and medical history. Always consult a physician before using a swim spa to understand your particular tolerance and limitations.





READ AND FOLLOW ALL INSTRUCTIONS

WARNING – To reduce the risk of injury, do not permit children to use this product unless they are closely supervised at all times.

A wire connector is provided on this unit to connect a minimum #6 (AWG) solid copper conductor between this unit and any metal equipment, metal enclosures of electrical equipment, metal water pipe, or conduit within 5 feet (1.5 m) of the unit.

**** For units with GFCI:**  **Warning** – This product is provided with a ground-fault circuit interrupter located in the main panel. The GFCI must be tested before each spa use.

Dangers

-  **RISK OF ACCIDENTAL DROWNING:** Extreme caution must be exercised to prevent unauthorized access by children. To avoid accidents, ensure that children cannot use this spa unless they are supervised at all times. Always cover the swim spa and use safety locks when it is not in use.
-  **RISK OF INJURY:** The suction fittings in this spa are sized to match the specific water flow created by the pump. Should the need arise to replace the suction fittings or the pump, be sure that the flow rates are compatible. Never operate the spa if the suction fittings are broken or missing. Never replace a suction fitting with one rated less than the flow rate marked on the original suction fitting.
-  **RISK OF ELECTRIC SHOCK:** Install at least 5 feet (1.5 m) from all metal surfaces. As an alternative, a spa may be installed within 5 feet of metal surfaces if each metal surface is permanently connected by a minimum #6 (AWG) solid copper conductor to the wire connector on the terminal box that is provided for this purpose.
-  **RISK OF ELECTRIC SHOCK:** Do not permit any electric appliance, such as a light, telephone, radio or television, within 5 feet (1.5 m) of a spa. Do not operate such an appliance from either inside the swim spa or when you are wet, unless such appliances are built-in by the manufacturer.

NO DIVING

DANGER: DIVING MY RESULT IN SERIOUS INJURY OR DEATH

Warnings

⚠ TO REDUCE THE RISK OF INJURY:

- The water in a spa should never exceed 40°C (104°F). Water temperatures between 38°C (100°F) and 40°C (104°F) are considered safe for a healthy adult. Lower water temperatures are recommended for young children and when spa use exceeds 10 minutes.
 - Since excessive water temperatures have a high potential for causing fetal damage during the early months of pregnancy, pregnant or possible pregnant women should limit spa water temperatures to 38°C (100°F).
 - Before entering a spa/swim spa, the user should measure the water temperature since the tolerance of water temperature regulating devices varies.
 - The use of alcohol, drugs or medication before or during spa/swim spa use may lead to unconsciousness with the possibility of drowning.
 - Obese persons and persons with a history of heart disease, low or high blood pressure, circulatory system problems, or diabetes should consult a physician before using a spa.
 - Persons using medication should consult a physician before using a spa/swim spa since some medication may include drowsiness while other medication may affect heart rate, blood pressure and circulation.
- ⚠ Do not connect auxiliary components (such as headphones, cables, and additional speakers) to the stereo (if equipped).
 - ⚠ Do not use a swim spa immediately following strenuous exercise.
 - ⚠ Do not use your swim spa alone.
 - ⚠ Lock the cover on your swim spa when not in use.
 - ⚠ Persons with infectious diseases should not use a swim spa.
 - ⚠ Replace audio components only with identical components.
 - ⚠ Do not leave the CD/Stereo/MP3 access door open on the stereo (if equipped).
 - ⚠ Some types of hair dye can react with the sanitizers in your swim spa water causing your hair to change color. Use at your own risk.
 - ⚠ Water normally splashes out of a swim spa during typical use. Install an adequate perimeter that provides sound footing.
 - ⚠ Do not turn your swim spa on/off from a wall switch, ground fault circuit interrupter, circuit breaker, fuse, or by plugging/unplugging it.
 - ⚠ Remove all jewelry, metal, and watches from your person before entering your swim spa.
 - ⚠ Keep all breakables away from the swim spa area.
 - ⚠ Maintain water balance in accordance with instructions.
 - ⚠ Do not sit on lip of the spa.

NO DIVING

DANGER: DIVING MY RESULT IN SERIOUS INJURY OR DEATH

Warning Sign



Warning Sign Must Be Posted – The red WARNING sign like the one shown is packed with your new swim spa. This sign must be posted in a prominent place in close proximity to the swim spa installation site immediately upon completion of swim spa installation.

Figure 2 – Warning Sign

Important: It is extremely important that this sign be permanently placed in clear view of persons using the swim spa. Occasional swim spa users may not be aware of some of the dangers hot water poses to pregnant women, small children, seniors, and people under the influence of alcohol. If you did not receive a warning sign or your sign has become damaged, please call your local dealer for a replacement.

Hyperthermia

To reduce the risk of injury, the water temperature in a swim spa should never exceed 104°F (40°C). Water temperatures between 100°F (38°C) and 104°F (40°C) are considered safe for a healthy adult. Lower water temperatures are recommended for young children, senior citizens, persons with sensitivities, and when swim spa use exceeds 10 minutes.

WATER TEMPERATURE IN EXCESS OF 100°F (38°C) MAY BE INJURIOUS TO YOUR HEALTH.

Hyperthermia occurs when the internal temperature of the body reaches a level several degrees above the normal body temperature of 98.6°F (37°C). The symptoms of hyperthermia include drowsiness, lethargy, and an increase in the internal temperature of the body. The effects of hyperthermia include:

- ⚠ Unawareness of impending hazard
- ⚠ Failure to perceive heat
- ⚠ Failure to recognize the need to exit swim spa
- ⚠ Physical inability to exit swim spa
- ⚠ Fetal damage in pregnant women
- ⚠ Unconsciousness and danger of drowning

If you sense any of the symptoms of hyperthermia, safely exit the swim spa immediately.

SAVE THESE INSTRUCTIONS

Basic Safety Guidelines

Your hot tub is meant to be enjoyable, healthful, and relaxing. Below are some basic safety guidelines to follow every time you use your hot tub.

- Always check the temperature of your hot tub before entering. High water temperatures can be hazardous to your health.
- Persons suffering from heart disease, diabetes, high or low blood pressure, and pregnant women should consult a doctor before using your hot tub.
- Persons under the influence of medication, drugs, or alcohol should not be allowed into your hot tub.
- Remove all jewelry, metal, and watches from your person before entering your hot tub.
- Do not allow children to use your hot tub without continuous supervision of an adult.
- Do not use your hot tub alone.
- Test the ground fault circuit interrupter (GFCI) breaker prior to using your hot tub each time to ensure it operates properly.
- Any electrical devices near your hot tub must be GFCI protected and out of reach from inside the hot tub.
- Keep all breakables away from the hot tub area.
- Lock the cover on your hot tub when not in use.
- Enter and exit the hot tub slowly. Wet surfaces can be slippery.
- Prolonged immersion can be hazardous to your health.

Maintain water chemistry in accordance with manufacturer's instructions.

- The hot tub is not to be used by persons with reduced physical, sensory or mental capabilities, or lack of experience and knowledge, unless they have been given supervision or instruction
- Do not sit on lip of spa.

NO DIVING

DANGER: DIVING MY RESULT IN SERIOUS INJURY OR DEATH

Basic Water Quality Guidelines

- *During the initial filling of the spa, add a sequestering agent to combat suspended minerals in the water. Allow water to circulate and filter for at least 12 hours before adding any other chemicals.*
- *Test water for PH, total Alkalinity, and Calcium hardness. The PH should be 7.2-7.8 and the total Alkalinity 80-180 PPM. Calcium hardness levels should be maintained between 150 and 400 PPM. Adjust PH and total Alkalinity (TA) utilizing the directions on the chemical bottles. Wait 15-30 minutes, test and adjust if necessary.*
- *Add 2 ounces of concentrated chlorinating granules (sodium Dichlor-s-triazinetreone) on initial start up to begin sanitizing the spa water. It is important not to add the chlorinating granules until the PH, alkalinity and calcium hardness have been adjusted to their proper levels.*
- *Check spa water with test strip for proper sanitation levels and adjust accordingly to the proper levels. Free chlorine should be 2-4 PPM.*
- *We recommend a minimum level of 2 PPM residual chlorine be maintained in spa water. Be sure the pumps are running when adding chlorine or non chlorine shock/oxidizer.*
- *Add 1 ounce of non-chlorine shock/oxidizer or ½ ounce of chlorine to the spa water after each spa use.*

For Swim spas Equipped with Audio Components

Audio components are optional and not available on all models.

 **WARNING: Prevent Electrocuton:** Do not connect any auxiliary components – for example, cable, additional speakers, headphones, etc., – to the system.

 **Caution: Risk of Electric Shock:** Do not leave audio compartment door open. Replace audio components only with identical components.

Site Selection and Installation

Proper planning is an important consideration when installing your new swim spa. Site selection is a critical step and requires serious thought. Planning ahead makes the installation process easier. The following information is provided to assist you in site preparations.

- 1) Always comply with local building codes and obtain any necessary permits. You may also need to consult with an engineer to address your specific design needs.
- 2) Contact an electrician to assess your electrical needs, install wiring, and assure a safe operation.
- 3) Position your swim spa with proper access to water, drainage, and electricity.
- 4) For **external installations**, place your swim spa on a uniform solid, flat surface designed to properly support its weight. For external installations, a level concrete pad or properly constructed deck capable of supporting 200 lbs/ft² (925 kg/m²) should be installed. For best results, we suggest the installation of a level concrete pad. Dig out and level the ground 8-12 inches (20-30 cm) below your desired base level. Install 4-6 inches (10-15 cm) of crushed stone. Next, install 4-6 inches (10-15 cm) of poured concrete and level it with a broom-type finish. Decks constructed flush to the swim spa should slope away for proper run off. In regions where freeze/thaw occurs, or where there will be custom decking abutting the swim spa, we recommend the installation of poured concrete footings extending below the frost line beneath the pad to prevent the possibility of future shifting.
- 5) For **internal installations**, check the load carrying capabilities of the floor on which the swim spa will reside. The ceiling should be more than 10 feet high (for safe entry and use), the floor should have a drain for splash over and the room should have a window or exhaust fan with humidistat for ventilation. If this is not possible, indoor/outdoor carpeting and the use of a dehumidifier while the cover is off should be adequate.
- 6) For **partial in-ground installations** (not recommended), follow these tips: In non-freezing climates it is sufficient to ensure that the base of the hole or cavity created for the swim spa simply has a stable, compacted base. Where the climate permits, should you choose to backfill directly against the swim spa, a clear sand backfill is suggested. Never fill using raw earth and never cover electrical components or plumbing connections. • In climates where freeze/thaw occurs, it is necessary that a proper poured concrete base, complete with concrete footings. • In areas with a high ground water table, the concrete base, as well as a concrete or wood retaining wall to hold back the earth, is suggested. This forms a box or "crib/vault" where the swim spa is placed. After excavating the installation site for your Premium Leisure swim spa, ensure that the soil underlying the foundation is capable of supporting a minimum of 1,000 lbs/ ft² or 12,206 kg/m² • ALWAYS ensure that there is good drainage, via a properly designed (gravel) drain system and/or a sump pump, to prevent ground water flooding damage to the

support equipment or structure. Install protective waterproof conduit to house light, or topside control cables that must be buried. Access for future service must be considered at the time of design and installation. Difficult access can result in supplemental service labor charges not covered by the factory warranty. Consider easily removable deck materials.

- 7) Assure that your swim spa will fit into the space you have chosen and the delivery route will accommodate its large size. In most cases, a crane will be necessary for the delivery.
- 8) Provide adequate ventilation for the humidity created by your swim spa. In most cases, a Swim spa Hard Cover is sufficient.
- 9) Protect the pumps and all equipment from the weather by ensuring the cabinet panels are secure at all times.
- 10) Allow 36 inches (1 meter) of unobstructed access to all sides of your swim spa for normal servicing.
- 11) Contact your local building code department to determine if a building permit is necessary and for information on applicable bylaws (distance from property lines, buildings, fencing requirements, etc). In most cases, the shallow depth of the unit could result in it being classified as a *portable* swim spa by building regulations (as opposed to a *permanent* pool).
- 12) Consider positioning your swim spa out of or adequately protecting it from the wind. Just as people can get cold on cool/windy days, so can your swim spa. Windy environments can significantly increase operating costs.



Figure 3 – A Crane is a Common Delivery Arrangement for Swim Spas

Electrical Specifications

Important – Qualified and licensed electricians must perform all electrical hookups. The following specifications must be followed in order to ensure proper performance and safety.

⚠ WARNING: Starting an incorrectly wired swim spa could cause severe damage to the mechanical equipment or even bodily harm. Have your licensed electrician verify GFCI (or RCD) wiring with the diagrams on pages 12-23 prior to starting the swim spa or call the technical support line at 727.573.9611.

⚠ Caution: Failure to abide by specifications listed may result in damage to the equipment and will void the warranty. All swim spas must be wired with the appropriately sized wiring. Failure to do so will cause equipment damage and will not be covered under your warranty. All swim spas must be over current protected with a built-in GFCI (or RCD) in the service panel.

Model	Service 1 control (controller, spa panel)	Service 2 control (controller, spa panel)	Volts/ Frequency VAC/HZ	GFCI/RCD Required in AMPS Service1/ Service2	Wire size required Service1/ Service 2
DZ 18 (2022)	PEL2SWIM, ML700	VS500Z/ MVP260	240/120/60	60/40	4 Wire #6 / 4 Wire #8
S18 (2028)	PEL2SWIM, ML900, AX20	N/A	240/120/60	60	4 Wire #6
AQ X14 (1208D), AQ14 (1208)	PEL2SWIM, ML900, AX20	N/A	240/120/60	60	4 Wire #6
AQ X12 (1209D), AQ12 (1209)	PEL2SWIM, ML700, AX20	N/A	240/120/60	60	4 Wire #6
AQ X11 (1214D), AQ11 (1214)	PEL2SWIM, ML700, AX20	N/A	240/120/60	60	4 Wire #6
AQ X10 (1210D)	PEL2P3S2, ML700	N/A	240/120/60	60	4 Wire#6
AQ X16 (1211D), AQ16 (1211)	PEL2SWIM, ML900, AX20	VS500Z/ MVP260	240/120/60	60/40	4Wire#6/ 4 Wire#8

ES14(1303)	VS515Z VL260	N/A	240/120/60	50	4 Wire#8
DZ18-EX (2022-EX)	PGL2P3P4, ML700	GS500Z, MVP260	220-240/50	1x32 or 3x16/1x32	3x4mm ² or 5x1.5mm ² / 3x4mm ²
S18-EX (2028-EX)	PGL2P3P4, ML900, AX20	N/A	220-240/50	1x32 or 3x16	3x4mm ² or 5x1.5mm ²
AQ X14-EX (1208D-EX), AQ14 (1208-EX)	PGL2P3P4 ML900, AX20	N/A	220-240/50	1x32 or 3x16	3x4mm ² or 5x1.5mm ²
AQ X12-EX (1209D-EX), AQ12 (1209-EX)	PGL2P3P4 ML700, AX20	N/A	220-240/50	1x32 or 3x16	3x4mm ² or 5x1.5mm ²
AQ X10-EX (1210D-EX),	PGK2P3P4, ML700	N/A	220-240/50	1x32 or 3x16	3x4mm ² or 5x1.5mm ²
AQ X16-EX (1211D-EX), AQ16(1211-EX)	PGL2P3P4, ML900, AX20	GS500Z, MVP260	220-240/50	1x32 or 3x16/1x32	3x4mm ² or 5x1.5mm ² / 3x4mm ²
AQ X11-EX (1214D-EX), AQ11(1214-EX)	PGL2P3P4, ML700, AX20	N/A	220-240/50	1x32 or 3x16	3x4mm ² or 5x1.5mm ²
ES14-EX (1303-EX)	GS510SZ, VL600S	N/A	220-240/50	1x32	3x4mm ²

Table 1 – Domestic/Export (in Gray) Electrical Specification Chart

NOTE: The Service 1 and the Service 2 will need to be wired independently.

⚠ WARNING: Disconnect electrical power before servicing. Before obtaining access to terminals, all supply circuits must be disconnected.

⚠ WARNING: Test the GFCI (or RCD) before each use.



Our swim spas are certified by Intertek Testing, SNAa Ltd. Ontario, Canada to CSA-C22.2 No. 218.1-M89 and ANSI/UL 1563 standards.



Wiring Diagrams

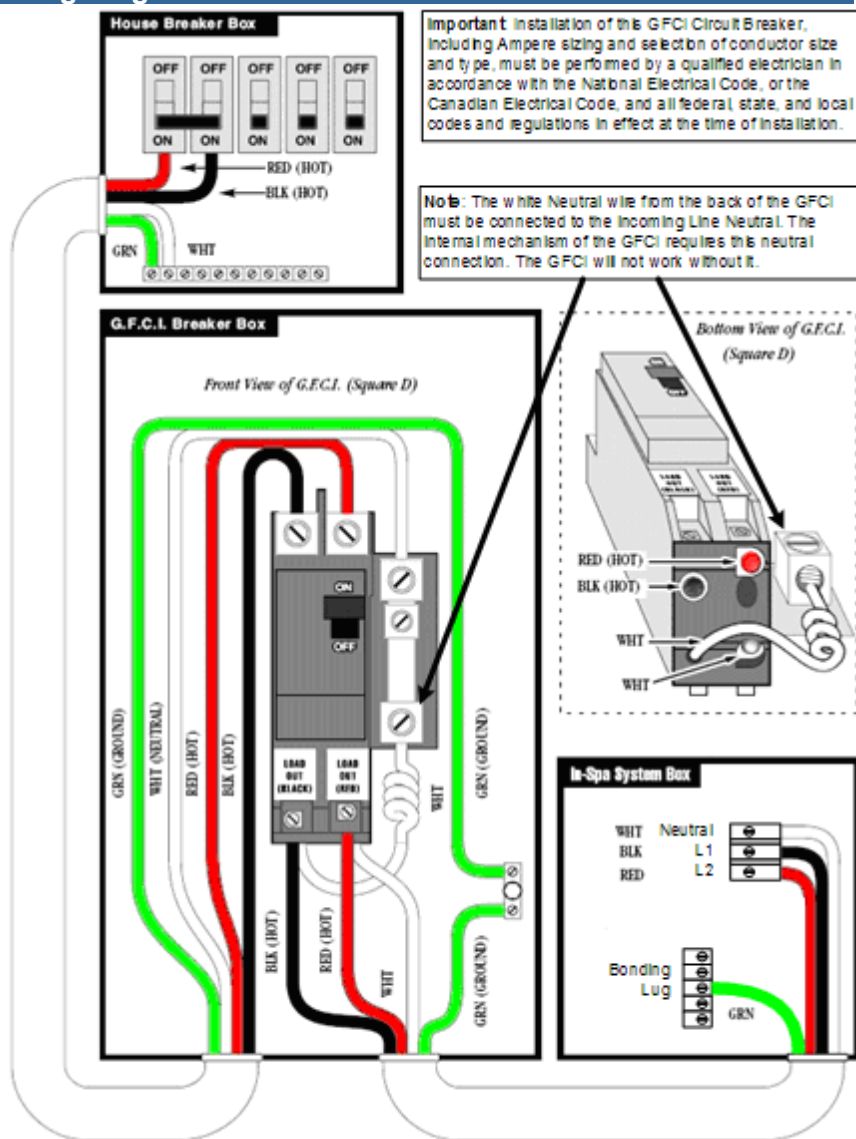

Figure 4 – Electrical Service for all domestic Single-phase 240vac models

See wire size chart on page 10-11

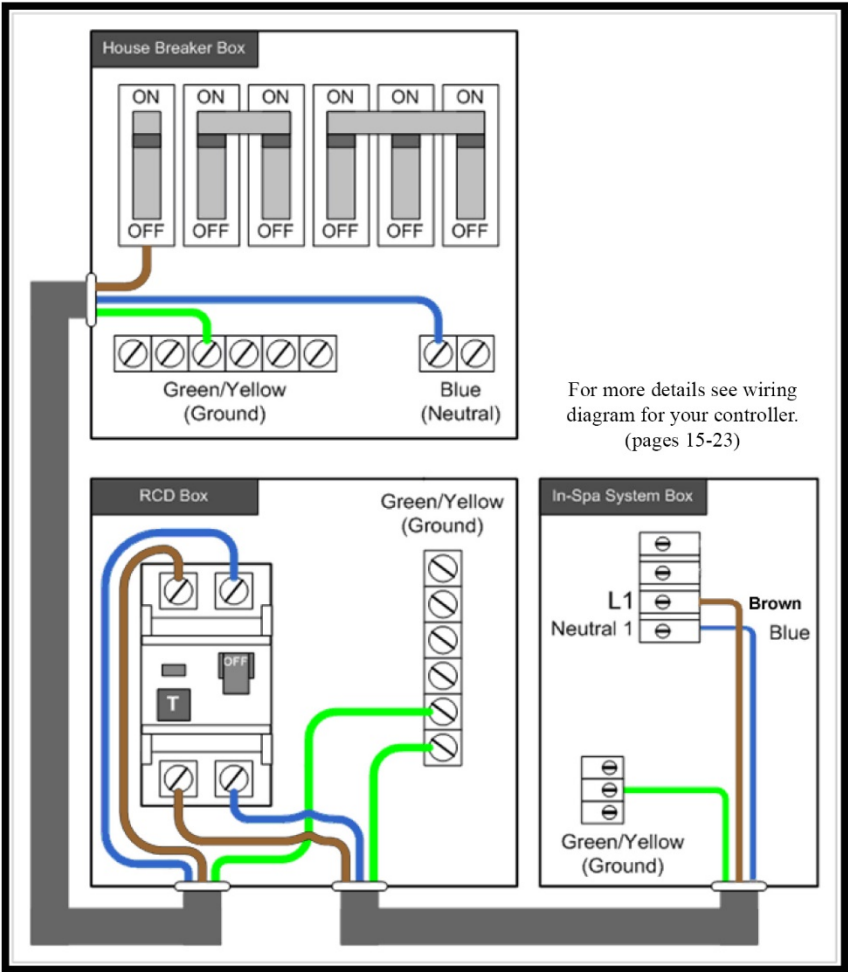

Figure 5 – Electrical Service for export models, single service 1x32A, applications.

All wiring is 3x4 mm², solid copper
See wire size chart on page 11

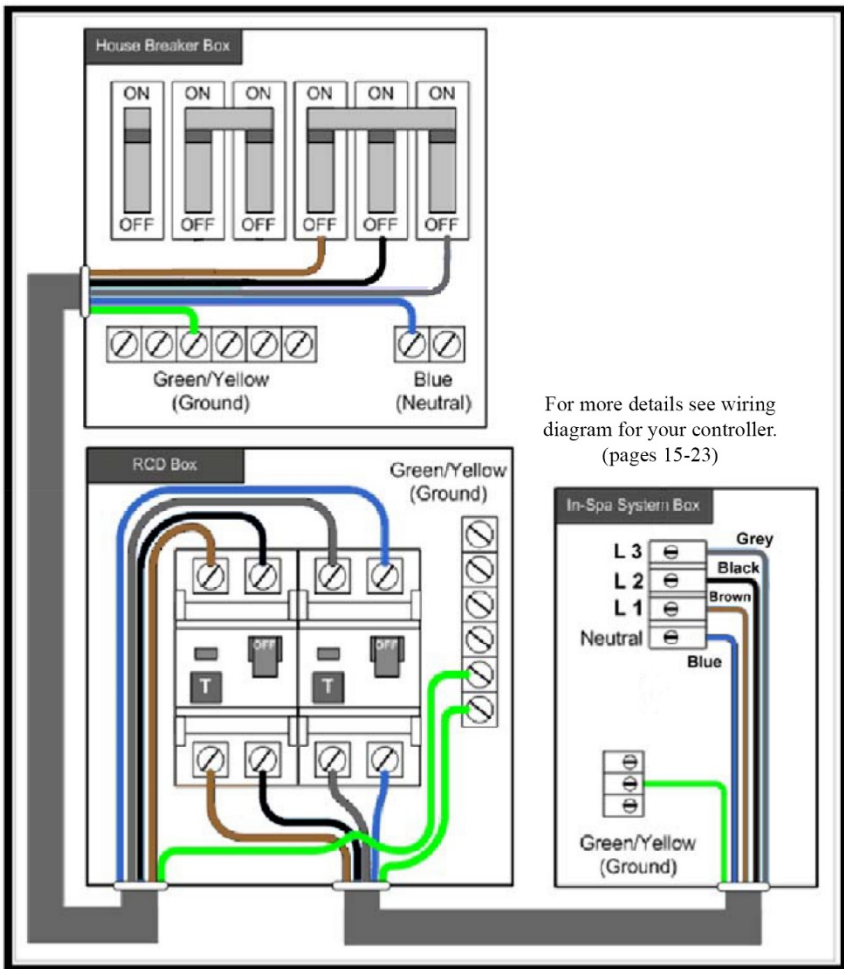

Figure 6 – Electrical Service for three phase, 3x16A applications.

All wiring is 5x1.5 mm², solid copper
See wire size chart on page 11

Wiring Diagrams

PEL2SWIM — PN 56261-01

ML (MAIN) PANELS
J70, J71 or J72

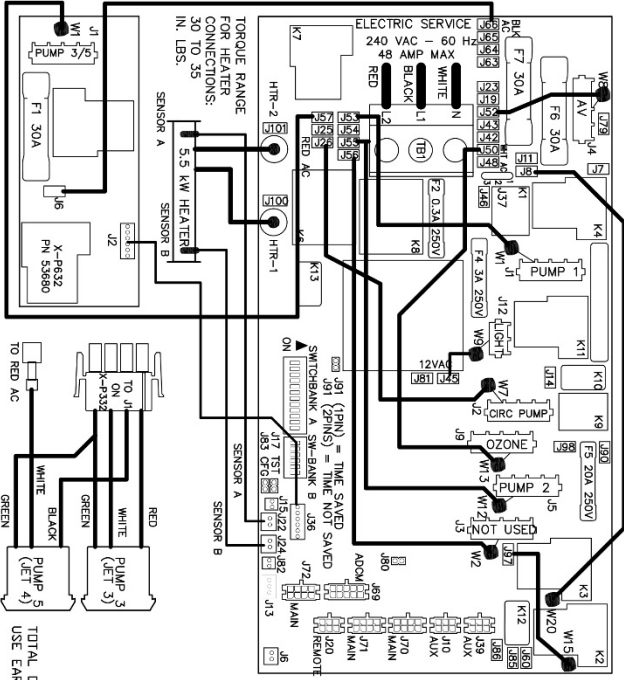

J83 ON 2 PINS

SWITCHBANK A OFF (DOWN) SWITCHBANK A ON (UP)

TEST MODE	OFF	A1	A2	A3	A4	A5	A6	A7	A8	A9	A10	A11	A12
DNRT ADD 1 HS PUMP V/HTH	▲	▲	▲	▲	▲	▲	▲	▲	▲	▲	▲	▲	▲
DNRT ADD 2 HS PUMPS V/HTH	▲	▲	▲	▲	▲	▲	▲	▲	▲	▲	▲	▲	▲
DNRT ADD 4 HS PUMPS V/HTH	▲	▲	▲	▲	▲	▲	▲	▲	▲	▲	▲	▲	▲
MUST BE OFF	▲	▲	▲	▲	▲	▲	▲	▲	▲	▲	▲	▲	▲
BLOWER DISABLED	▲	▲	▲	▲	▲	▲	▲	▲	▲	▲	▲	▲	▲
NOT ASSIGNED	▲	▲	▲	▲	▲	▲	▲	▲	▲	▲	▲	▲	▲
NOT ASSIGNED	▲	▲	▲	▲	▲	▲	▲	▲	▲	▲	▲	▲	▲
ND EDIT	▲	▲	▲	▲	▲	▲	▲	▲	▲	▲	▲	▲	▲
SPECIAL APE RULE DISABLED	▲	▲	▲	▲	▲	▲	▲	▲	▲	▲	▲	▲	▲
STORE SETTINGS	▲	▲	▲	▲	▲	▲	▲	▲	▲	▲	▲	▲	▲
	▲	▲	▲	▲	▲	▲	▲	▲	▲	▲	▲	▲	▲

SWITCHBANK B OFF (DOWN)	SWITCHBANK B ON (UP)
NOT ASSIGNED	▲ B1
NOT ASSIGNED	▲ B2
NOT ASSIGNED	▲ B3
NOT ASSIGNED	▲ B4
NOT ASSIGNED	▲ B5
NOT ASSIGNED	▲ B6

ALL UNUSED SWITCHES SHOULD BE OFF

LOCATION	DEVICE	VOLTS	AMPS	FRM	TO
J1	2 SPD P1	240V	12A	W7	RED AC
J2	CIRC PUMP	240V	4A	W7	RED AC
J3	NDT USED	240V	8A	W2	RED AC
J4	A V	120V	2A	W8	WHT AC
J5	1 SPD P2	240V	12A	W12	RED AC
J6	DZINE	120V	1A	W13	WHT AC
J9	LIGHT	120V**	2A	W9	JH5
J12	HEATER	240V	5.5KW	HTR TERM	HTR 1/2

**J37 MUST ALSO BE SET ON PINS 2 AND 3 FOR A 12V SPA LIGHT
TOTAL OUTPUT AMP DRAW NOT TO EXCEED MAX INPUT RATING OF SPA
USE EARTH GROUND CONNECTIONS AS INDICATED INSIDE THE SYSTEM ENCLOSURE

LOCATION	DEVICE	VOLTS	AMPS	FROM	TO
J1 ON EXPANDER	1 SPD PUMP 3/5	240V	12A	W1 ON EXPANDER	RED AC

CONNECT ONLY TO CIRCUITS PROTECTED BY A CLASS A GFCI.
A DISCONNECT MEANS MUST BE INSTALLED WITHIN SIGHT FROM THE EQUIPMENT AND AT LEAST 5 FEET (1.52 M) FROM THE INSIDE WALLS OF THE POOL, SPA, OR HOT TUB.
FOR SUPPLY CONNECTIONS, USE CONDUCTORS SIZED ON THE BASIS OF 60°C AMPACITY BUT RATED MINIMUM OF 75°C.

TORQUE RANGE FOR MAIN TERMINAL BLOCK (TR):
DES CONDUCTORS USE COPPER CONDUCTORS ONLY.
EMPLOYER UNIFORMMENT USE CONDUCTORS OF 75 CUIVARE.
DES AND MIN. WIRE-DE.

Figure 7

PEL2P3S2 — PN 56424

M(L/MAN)PANELS
J70, J71 or J72

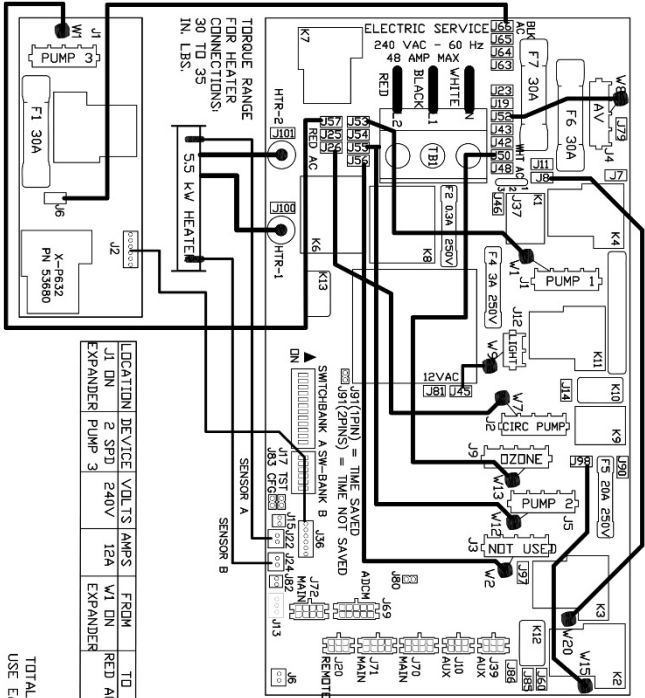

LOCATION	DEVICE	VOLTS	AMPS	FROM	TO
J1 DN	2 SPD	240V	12A	RED AC	EXPANDER
J2	PUMP 3	240V	12A	RED AC	EXPANDER

J83 ON 2 PINS SWITCHBANK A OFF (DOWN) SWITCHBANK A ON (UP)

TEST MODE OFF	TEST MODE ON
▶ A1	▶ A1
▶ A2	▶ A2
▶ A3	▶ A3
▶ A4	▶ A4
▶ A5	▶ A5
▶ A6	▶ A6
▶ A7	▶ A7
▶ A8	▶ A8
▶ A9	▶ A9
▶ A10	▶ A10
▶ A11	▶ A11
▶ A12	▶ A12

SWITCHBANK B OFF (DOWN)	SWITCHBANK B ON (UP)
▶ B1	▶ B1
▶ B2	▶ B2
▶ B3	▶ B3
▶ B4	▶ B4
▶ B5	▶ B5
▶ B6	▶ B6

ALL UNUSED SWITCHES SHOULD BE OFF

LOCATION	DEVICE	VOLTS	AMPS	FROM	TO
J1	2 SPD	240V	12A	V1	RED AC
J2	CIRC PUMP	240V	4A	V7	RED AC
J3	NOT USED	240V	8A	V2	RED AC
J4	AV	120V	2A	V8	WHIT AC
J5	2 SPD P2	240V	12A	V12	RED AC
J9	DZONE	120V	1A	V13	WHIT AC
J12	HEATER	240V	5.5KW	V9	WHIT AC
	HTR	240V	5.5KW	V9	HTR 1/2

***J37 MUST ALSO BE SET ON PINS 2 AND 3 FOR A 12V SPA LIGHT

TOTAL OUTPUT AMP DRAW NOT TO EXCEED MAX INPUT RATING OF SPA
USE EARTH GROUND CONNECTIONS AS INDICATED INSIDE THE SYSTEM ENCLOSURE

CONNECT ONLY TO CIRCUITS PROTECTED BY A CLASS A GFCI.

A DISCONNECTING MEANS MUST BE INSTALLED WITHIN SIGHT FROM THE EQUIPMENT AND AT LEAST 5 FEET (1.52 M) FROM THE INSIDE WALLS OF THE PDU, SPA, OR HOT TUB.

TORQUE RANGE FOR MAIN TERMINAL BLOCK (TB):
27—30 IN. LBS.

USE COPPER CONDUCTORS ONLY.

EMPLOYER UNREQUIREMENT?
DES CONDUCTEURS DE CUIVRE.
#6 AWG MIN. WIRE = 75°

FDR SUPPLY CONNECTIONS.
USE CONDUCTORS SIZED ON THE BASIS OF 60% CAPACITY BUT RATED MINIMUM OF 75%.

Figure 8

VS 510SZ/HS200VS-PN 55098-02

CONTROL PANEL TO J1

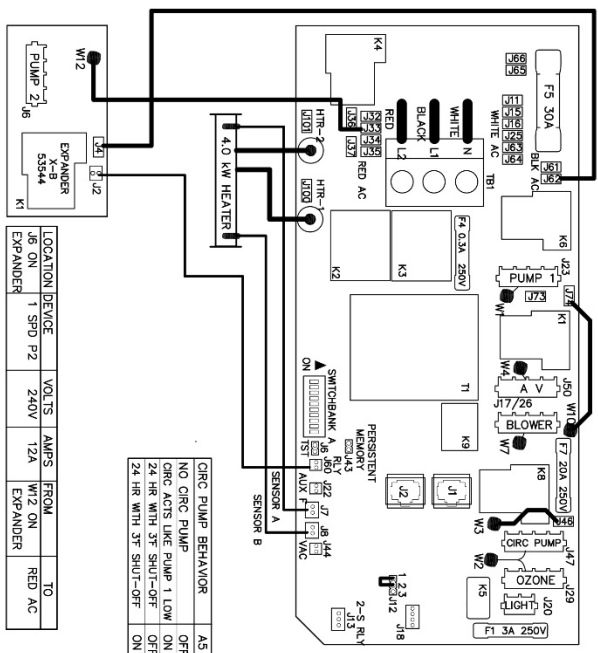

CIRC PUMP BEHAVIOR	A5	A6	PUMP 1 SPEEDS
NO CIRC PUMP	OFF	OFF	2-SPEED
CIRC ACTS LIKE PUMP 1 LOW	ON	OFF	1-SPEED
24 HR WHT 3T SHUT-OFF	ON	ON	2-SPEED
24 HR WHT 3T SHUT-OFF	ON	ON	2-SPEED

TEST MODE OFF	A1	TEST MODE ON	A2	TEST MODE ON
SEE TABLE 1	A2	SEE TABLE 1	A3	SEE TABLE 1
EXT RELAY BOARD DISABLED	A3	EXT RELAY BOARD ENABLED	A4	EXT RELAY BOARD ENABLED
AUX FREEZE MUST BE OFF	A4	AUX FREEZE MUST BE OFF	A5	AUX FREEZE MUST BE OFF
SEE CIRC PUMP BEHAVIOR	A5	SEE CIRC PUMP BEHAVIOR	A6	SEE CIRC PUMP BEHAVIOR
60HZ	A6	50HZ	A7	50HZ
J17/26 DISABLED	A7	J17/26 ENABLED	A8	J17/26 ENABLED
DEGREES F	A8	DEGREES C	A9	DEGREES C
SEE CIRC PUMP BEHAVIOR	A9	SEE CIRC PUMP BEHAVIOR	A10	SEE CIRC PUMP BEHAVIOR
SEE TABLE 1	A10	SEE TABLE 1		

ALL UNUSED SWITCHES SHOULD BE OFF

TABLE 1	A1	A2	A10
# OF HIGH-SPEED PUMPS AND/OR BLOWER WITH HEATER	0	OFF	OFF
0 HIGH-SPEED PUMP OR BLOWER	1	ON	OFF
1 HIGH-SPEED PUMP OR BLOWER	2	ON	OFF
2 HIGH-SPEED PUMPS OR 1 HIGH-SPEED PUMP AND BLOWER	3	ON	ON
3 HIGH-SPEED PUMPS OR 2 HIGH-SPEED PUMPS AND BLOWER			

LOCATION	DEVICE	VOLTS	AMPS	FROM	TO
J23	2 SPD P1	240V	12A	W1	RED AC
J47	CIRC PUMP	240V	4A	W2	RED AC
J17/26	BLOWER	120V	12A	W7	WHT AC
J50	AV	120V	2A	W4	WHT AC
J29	OZONE	120V	1A	W2	WHT AC
J20	LIGHT	12V	12W		
J20	HEATER	240V	4.0KW	HR TERM	HR 1/2

TOTAL OUTPUT AMP DRAW NOT TO EXCEED MAX INPUT RATING OF SPA
CIRC PUMP IS AN OPTIONAL DEVICE. SEE CIRC PUMP BEHAVIOR TABLE.

CONNECT ONLY TO CIRCUITS PROTECTED BY A CLASS A GFCI.
A DISCONNECTING MEANS MUST BE INSTALLED WITHIN SIGHT FROM THE EQUIPMENT AND AT LEAST 5 FEET (1.52 M) FROM THE INSIDE WALLS OF THE POOL, SPA, OR HOT TUB.
USE COPPER CONDUCTORS ONLY.
#6 AWG MIN. WIRE= 90°
FOR SUPPLY CONNECTIONS.
USE CONDUCTORS SIZED ON THE BASIS OF 60°C AMPACITY BUT USE EARTH GROUND CONNECTIONS AS INDICATED INSIDE THE SYSTEM ENCLOSURE.

TORQUE RANGE FOR MAIN TERMINAL BLOCK:
7-30 IN. LBS.
7-30 IN. LBS.
FOR HEATER CONNECTIONS:
30 TO 35 IN. LBS.

Figure 9

PVS500Z — PN 55940 240VAC ONLY DEVICES

CONTROL PANEL
TO J1

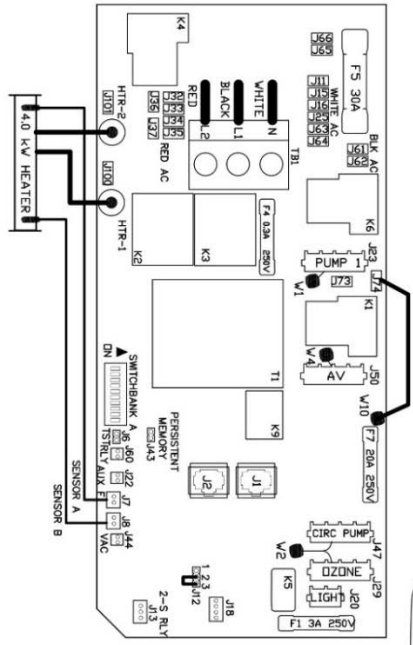

A DISCONNECTING MEANS MUST BE INSTALLED WITHIN SIGHT FROM THE EQUIPMENT AND AT LEAST 5 FEET (1.52 M) FROM THE INSIDE WALLS OF THE POOL SPA, OR HOT TUB.
USE COPPER CONDUCTORS ONLY.
EMULDER UNDERMENT
DES CONDUCTEURS DE CUIVRE.
#6 AVG MIN. WIRE—90°
FOR SUPPLY CONNECTIONS.
USE CONDUCTORS SIZED ON THE BASIS OF 60% AMPACITY BUT RATED MINIMUM OF 90%.
USE EARTH GROUND CONNECTIONS AS INDICATED INSIDE THE SYSTEM ENCLOSURE

TORQUE RANGE FOR MAIN TERMINAL BLOCKS: 27-30 IN. LBS.
TORQUE RANGE FOR HEATER CONNECTIONS: 30 TO 35 IN. LBS.

ALL UNUSED SWITCHES SHOULD BE OFF

CIRC PUMP BEHAVIOR	A5	A9	PUMP 1 SPEED
NO CIRC PUMP	OFF	OFF	2-SPEED
CIRC ACTS LIKE PUMP 1 LOW	DN	DN	1-SPEED
24 HR WITH 3% SHUT-OFF	OFF	DN	1-SPEED
24 HR WITH 9% SHUT-OFF	DN	DN	2-SPEED

SWITCHBANK A OFF (DOWN)	SWITCHBANK A ON (UP)	
TEST MODE OFF	▲ A1	TEST MODE ON
UNISEP/RET/TEMP/LIGHT	▲ A2	JET/LIGHT/DOWN/UP
DISC DR. LT. DRYEX PANEL	▲ A3	MINI PANEL
AUX FREEZE (CHST BE OFF)	▲ A4	AUX FREEZE (CHST BE OFF)
SEE CIRC PUMP BEHAVIOR	▲ A5	SEE CIRC PUMP BEHAVIOR
60-HZ	▲ A6	50HZ
STD/ECV/SLEEP MODE	▲ A7	STANDARD MODE ONLY
DEGREES F	▲ A8	DEGREES C
SEE CIRC PUMP BEHAVIOR	▲ A9	SEE CIRC PUMP BEHAVIOR
HIGH AMP MODE	▲ A10	LOW AMP MODE

240V ONLY DEVICES

LOCATION/DEVICE	VOLTS	AMPS	FROM	TO
J23	2-SP	240V	V1	RED AC
J47	CIRC PUMP	240V	V2	RED AC
J50	AV	240V	V4	RED AC
J29	2ZONE	240V	V2	RED AC
J20	LIGHT	16V	V1	RED AC
J20	LIGHT	16V	V2	RED AC
HTR	HEATER	240V	HTR TERM	HTR 1/2

TOTAL OUTPUT AMP DRAW NOT TO EXCEED MAX INPUT RATING OF SPA. CIRC PUMP IS AN OPTIONAL DEVICE. SEE CIRC PUMP BEHAVIOR TABLE.

Figure 10

PVS515Z — PN 55584

CONTROL PANEL
TO J1

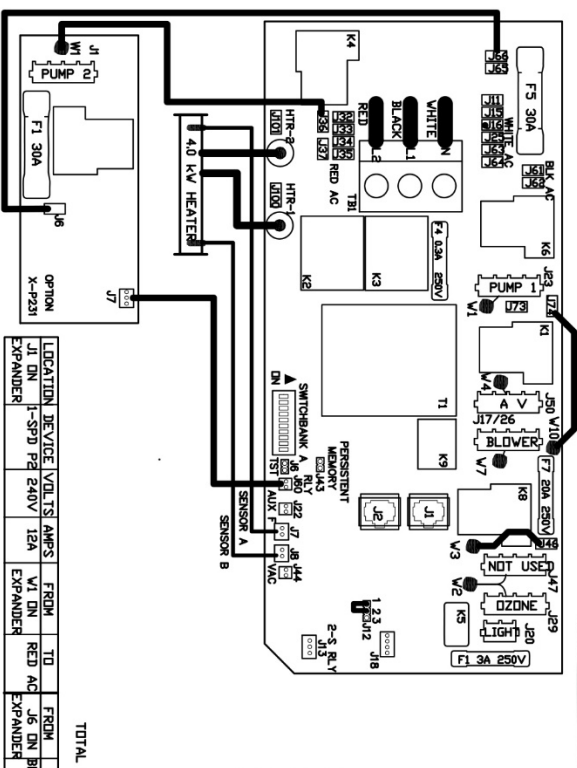

LOCATION	DEVICE	VOLT'S	AMPS	FROM	TO
J1 DN	1-SPD P2	240V	12A	EXPANDER	EXPANDER

TOTAL OUTPUT APP DRAW NOT TO EXCEED MAX INPUT RATING OF SPA
MCRIC PUMP IS NOT ALLOWED ON THIS MODEL.

LOCATION	DEVICE	VOLT'S	AMPS	FROM	TO
J3	2 SPD P1	240V	12A	V1	RED AC
J4	NET USED	120V	4A	V2	WHI AC
J17/26	BLOWER	240V	12A	V7	RED AC
J50	HTV	120V	2A	V4	WHI AC
J29	DLONE	120V	1A	V2	WHI AC
J29	LIGHT	12V	1A	V2	WHI AC
J18	HEATER	240V	4.0KW	HTR TERM	TR 1/2

TEST MODE OFF	MODES	STANDARD MODE ONLY
▲ A1	▲ A1	TEST MODE DN
▲ A2	▲ A2	STANDARD MODE ONLY
▲ A3	▲ A3	MINI PANEL
▲ A4	▲ A4	AUX FREEZE (ONST BE OFF)
▲ A5	▲ A5	EXT RELAY BOARD DISABLED
▲ A6	▲ A6	50HZ
▲ A7	▲ A7	SEE TABLE 1
▲ A8	▲ A8	DEGREGS F
▲ A9	▲ A9	J17/26 DISABLED
▲ A10	▲ A10	J17/26 ENABLED

TEST MODE OFF	MODES	STANDARD MODE ONLY
▲ A1	▲ A1	TEST MODE DN
▲ A2	▲ A2	STANDARD MODE ONLY
▲ A3	▲ A3	MINI PANEL
▲ A4	▲ A4	AUX FREEZE (ONST BE OFF)
▲ A5	▲ A5	EXT RELAY BOARD DISABLED
▲ A6	▲ A6	50HZ
▲ A7	▲ A7	SEE TABLE 1
▲ A8	▲ A8	DEGREGS F
▲ A9	▲ A9	J17/26 DISABLED
▲ A10	▲ A10	J17/26 ENABLED

CONNECT ONLY TO CIRCUITS PROTECTED BY A CLASS A GFCI.
A DISCONNECT MEANS MUST BE INSTALLED WITHIN SIGHT FROM THE EQUIPMENT AND AT LEAST 5 FEET AWAY FROM THE INSIDE WALLS OF THE POOL, SPA, OR HOT TUB.
USE COPPER CONDUCTORS ONLY.
EMPLOYER UNIFORMS
JES CONDUCTORS DIE CALVEE.
#6 AVG MIN. WIRE = 90'
FOR SUPPLY CONNECTIONS,
USE CONDUCTORS SIZED ON THE BASIS OF 60°C AMPACITY BUT RATED MINIMUM OF 90°C.
USE EARTH GROUND CONNECTIONS AS INDICATED INSIDE THE SYSTEM ENCLOSURE

TORQUE RANGE FOR MAIN TERMINAL BLOCK:
27-30 IN. LBS.
TORQUE RANGE FOR HEATER CONNECTIONS:
30 TO 35 IN. LBS.

Figure 11

PGL2P3P4 - PN 56502 (PAGE 1)

ML (MAIN) PANELS
J70, J71 or J72

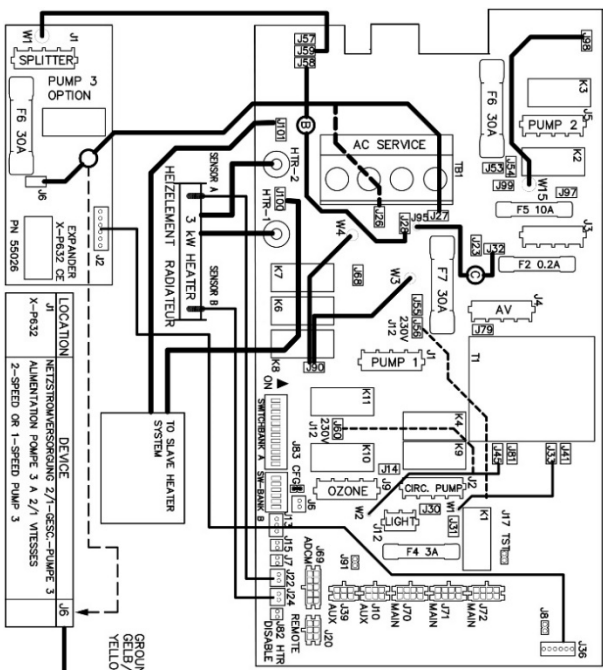

GROUND - TERRE - ERDE
GELB/GRÜN - JAUNE/VERT
YELLOW/GREEN

CIRC PUMP BEHAVIOR	A6	A7
NO CIRC PUMP	OFF	OFF
24-HR CIRC	OFF	ON
3- SHUT-OFF	ON	OFF
FILTERS/POOLS ONLY	ON	OFF

PUMP 2 BEHAVIOR	A8	A9
NO PUMP 2	OFF	OFF
ON / OFF WITH 2-SPEED	ON	OFF

PUMP 5 BEHAVIOR (JETS 4)	B4	B5
NO PUMP 5	OFF	OFF
ON / OFF WITH X-F632 PIN 2	ON	ON

* WITH SPECIAL AMPERAGE RULE ON, BLOWER WILL SHUT OFF WHEN 2ND HIGH SPEED PUMP IS ON.

ALL UNUSED SWITCHES SHOULD BE OFF

SWITCHBANK A OFF (DOWN)			SWITCHBANK A ON (UP)		
TEST MODE OFF	A1	A2	TEST MODE ON	A1	A2
POINT ADD 1 HS PUMP W/HR	▲ A1	▲ A2	ADD 1 HS PUMP WITH HEAT	▲ A1	▲ A2
DONT ADD 2 HS PUMPS W/HR	▲ A3	▲ A3	ADD 2 HS PUMPS WITH HEAT	▲ A3	▲ A3
DONT ADD 4 HS PUMPS W/HR	▲ A4	▲ A4	ADD 4 HS PUMPS WITH HEAT	▲ A4	▲ A4
M100 SPRINGING OFF	▲ A5	▲ A5	M100 SPRINGING ON	▲ A5	▲ A5
SEE CIRC PUMP BEHAVIOR	▲ A6	▲ A6	SEE CIRC PUMP BEHAVIOR	▲ A6	▲ A6
SEE CIRC PUMP BEHAVIOR	▲ A7	▲ A7	SEE CIRC PUMP BEHAVIOR	▲ A7	▲ A7
SEE CIRC PUMP BEHAVIOR	▲ A8	▲ A8	SEE CIRC PUMP BEHAVIOR	▲ A8	▲ A8
SEE PUMP 2 BEHAVIOR	▲ A9	▲ A9	SEE PUMP 2 BEHAVIOR	▲ A9	▲ A9
SEE PUMP 2 BEHAVIOR	▲ A10	▲ A10	EDIT MENU (NORMALLY OFF)	▲ A10	▲ A10
SPECIAL AMPERAGE RULE OFF	▲ A11	▲ A11	SPECIAL AMPERAGE RULE ON*	▲ A11	▲ A11
STORE SETTINGS	▲ A12	▲ A12	MEMORY RESET	▲ A12	▲ A12

SWITCHBANK B OFF (DOWN)			SWITCHBANK B ON (UP)		
SEE PUMP 3 BEHAVIOR	B1	B1	SEE PUMP 3 BEHAVIOR	B1	B1
SEE PUMP 3 BEHAVIOR	▲ B2	▲ B2	SEE PUMP 3 BEHAVIOR	▲ B2	▲ B2
SEE PUMP 3 BEHAVIOR	▲ B3	▲ B3	SEE PUMP 3 BEHAVIOR	▲ B3	▲ B3
SEE PUMP 5 BEHAVIOR	▲ B4	▲ B4	SEE PUMP 5 BEHAVIOR	▲ B4	▲ B4
SEE PUMP 5 BEHAVIOR	▲ B5	▲ B5	SEE PUMP 5 BEHAVIOR	▲ B5	▲ B5
NOT ASSIGNED	▲ B6	▲ B6	NOT ASSIGNED	▲ B6	▲ B6

PUMP 3 BEHAVIOR			
NO PUMP 3	B1	B2	B3
DN / BFR (ON BEMO)	OFF	OFF	OFF
DN / BFR (OFF BEMO)	OFF	ON	ON
DN / BFR (OFF BEMO)	ON	OFF	OFF
2-SPEED (X-F632)	ON	OFF	OFF

AC SERVICE				
230V 3P / 1x40A	WIRE (V) (WHT) (B) (BLK) (W) (GRN)	TO J23	TO J28	TO J28
400V 3P / 3x16A	REMOVE	REMOVE	REMOVE	REMOVE

Figure 12-A

3 X 16A

L1 (BR)|L2 (BR)|L3 (BR)|N (BL)

L1 _____ 230VAC 32A _____ N

BROWN BLUE
 BRAUN BLAU
 BRUN BLEU

Settings (Software Configured)

LOCATION	DEVICE
J1	NETZSTROMVERSORGUNG 2-DESCHN-PUMPE 1 ALIMENTATION PUMPE 1 A 2 VITESSES 2-SPEED PUMP 1
J2	VERSTÄRKER PUMPE 2-DESCHN-PUMPE 2 CIRCULATION CIRC PUMP
J4	TV / AV HEIZER STRÖHLER/CELSIUS BELEUCHT
J5	NETZSTROMVERSORGUNG 1/2-DES-PUMPE & ALIMENTATION PUMPE & A 1/2 VITESSES 1/2-SPEED P2
J9	DOZENERGIEKONVERTER GENERATORBROZENE ZONE GENERATOR
J12	BELEUCHTUNG EQUIPAGE BAIN HYDRO SPA LIGHT

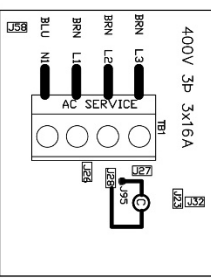
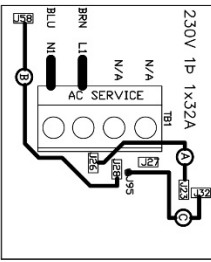
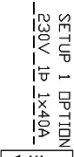
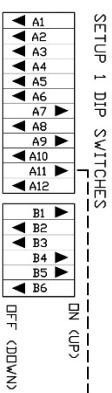

2-SPEED PUMP 1, 2-SPEED PUMP 2, 1-SPEED PUMP 3,
 1-SPEED PUMP 5, JETS 4, CIRC PUMP, DZINE, LIGHT, A/V HEATER,
 30 KW HEATER, ML900 MAIN PANEL, AX20A144 AUXILIARY PANEL

SETUP 2 DIP SWITCHES

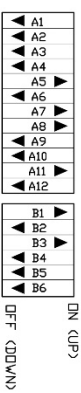

2-SPEED PUMP 1, 2-SPEED PUMP 2, 2-SPEED PUMP 3,
 CIRC PUMP, DZINE, LIGHT, A/V HEATER, 30 KW HEATER,
 ML700 MAIN PANEL, AX20A144 AUXILIARY PANEL

SETUP 3 DIP SWITCHES

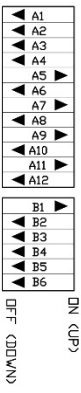

2-SPEED PUMP 1, 1-SPEED PUMP 2, 1-SPEED PUMP 3,
 CIRC PUMP, DZINE, LIGHT, A/V HEATER, 30 KW HEATER,
 ML700 MAIN PANEL

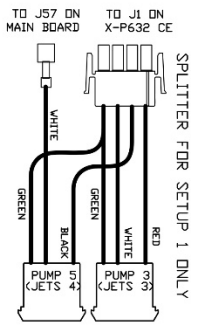

FOR SUPPLY CONNECTIONS, USE COPPER CONDUCTORS ONLY. CONDUCTORS SIZED ON THE BASIS OF 60°C AMPACITY. RATED MINIMUM OF 90°C.

USE COPPER CONDUCTORS ONLY. EMPLOYER UNDOUBTEDLY DES CONDUCTEURS DE CUIVRE. TORQUE RANGE FOR MAIN TERMINAL BLOCK (TB1): (31.1–34.5 kg cm)

Figure 12 – B

PGS510SZ — PN 55942-01

CONTROL PANEL
TO J1

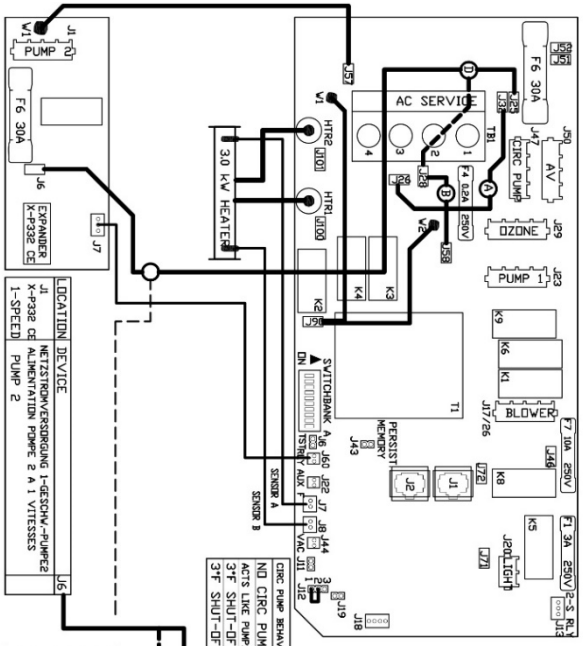

CIRC. PUMP BEHAVIOR	A5	A9	PUMP 1 SPEED
NO. CIRC. PUMP	OFF	OFF	2 SPEED
ACT. LINE PUMP	DN	DN	1 SPEED
3/F. SHUT-OFF	OFF	DN	1 SPEED
3/F. SHUT-OFF	DN	DN	2 SPEED

TABLE 1 - # OF HIGH-SPEED PUMPS AND/OR BLOWERS WITH HEATER	A2	A10
0 HIGH-SPEED PUMP OR BLOWER	OFF	OFF
1 HIGH-SPEED PUMP OR BLOWER	DN	DN
2 HIGH-SPEED PUMPS OR 1 HIGH-SPEED PUMP AND BLOWER	OFF	DN
3 HIGH-SPEED PUMPS OR 2 HIGH-SPEED PUMPS AND BLOWER	DN	DN

AC SERVICE	WIRE 1 (RED)	WIRE 2 (BLUE)	WIRE 3 (YELLOW)	WIRE 4 (GREEN)
230V 1P / 2416A-32A	J26 TO J32	J59 TO J28	T0 J25**	T0 J25**
230V 3P / 2416A	REMOVE	REMOVE	REMOVE	REMOVE
400V 3P / 2416A	REMOVE	REMOVE	REMOVE	REMOVE

** WIRE ORIGINATES FROM AN OPTIONAL EXPANDER BOARD

LOCATION	DEVICE
J29	NETZSTROMVERSORGUNG 2-DESCHU-PUMPE 1 ALIMENTATION PUMPE 1 A 2 VITESSES & SPEED PUMP 1
J17/76	WECHSELSTROM-STRUHLER-GEBLAUE BLOWER
J50	AV
J29	GENERATOR
J29	GENERATOR
J20	BELEUCHTUNG ECLAIRAGE BAIN HYDRO SPA LIGHT

USE COPPER CONDUCTORS ONLY.
EXPLOITER UNDERNET
CONDUCTEURS EN
#6 AWG MIN. WIRE = 90°
FOR SUPPLY CONNECTIONS.
USE CONDUCTORS SIZED ON THE
BASIS OF 60°C AMPACITY BUT
RATED MINIMUM OF 90°C.
GROUNDING TERMINAL VERT
YELLOW/GREEN

TORQUE RANGE
FOR HEATERS
CONNECTIONS:
1 BS
(34.5-40.3 kg cm)
TORQUE RANGE FOR
MAIN TERMINAL BLOCK (TB1)
27-30 IN. LBS.
(31.1-34.5 kg cm)

SWITCHBANK A OFF (DOWN) SWITCHBANK A ON (UP)

TEST MODE OFF	A1	TEST MODE ON
SEE TABLE 1	A2	SEE TABLE 1
EXT. RELAY BOARD DISABLED	A3	EXT. RELAY BOARD ENABLED
EXT. FREEZE STAT. BE OFF	A4	EXT. FREEZE STAT. BE ON
SEE CIRC. PUMP TABLE	A5	SEE CIRC. PUMP TABLE
SEE CIRC. PUMP TABLE	A6	SEE CIRC. PUMP TABLE
J17/76 BLOWER DISABLED	A8	J17/76 BLOWER ENABLED
DEGREES F	A9	DEGREES C
SEE CIRC. PUMP TABLE	A9	SEE CIRC. PUMP TABLE
SEE TABLE 1	A10	SEE TABLE 1

ALL UNUSED SWITCHES SHOULD BE OFF

Figure 13

GS500Z — PN 54509-01

CONTROL PANEL
TO J1

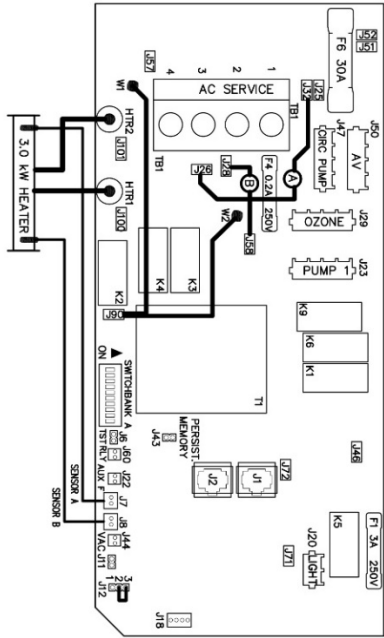

USE COPPER CONDUCTORS ONLY.
FOR HEATER
EMPILOYER UNCOULMENT
DES CONDUCTEURS DE CUIVRE.
#6 AWG MIN. WIRE= 90°
FOR SUPPLY CONNECTIONS,
USE CONDUCTORS SIZED ON THE
BASIS OF 60°C AMPACITY BUT
GROUND — TERRE — ERDE
GELB/GRÜN — JAUNE/VERT
YELLOW/GREEN

TORQUE RANGE
FOR HEATER
CONNECTIONS:
30 TO 35 N. LBS.
(34.5–40.3 kg cm)
TORQUE RANGE FOR
MAIN TERMINAL BLOCK (TB1):
27–30 IN. LBS.
(31.1–34.3 kg cm)

SWITCHBANK A OFF (DOWN)	SWITCHBANK A ON (UP)
TEST MODE OFF	▲ A1 TEST MODE ON
UNUSED/JE1/TEMP/LT	▲ A2 SET/LOHT/TEMP DOWN/TEMP UP
DDUP/LTDUP PANEL	▲ A3 MINI PANEL
MUST BE OFF	▲ A4 AUX FREEZE
SEE CIRC PUMP BEHAVIOR	▲ A5 SEE CIRC PUMP BEHAVIOR
60 Hz	▲ A6 50 Hz
STD./FCU/SLP MODES	▲ A7 STANDARD ONLY MODE
DEGREES F	▲ A8 DEGREES C
SEE CIRC PUMP BEHAVIOR	▲ A9 SEE CIRC PUMP BEHAVIOR
HIGH AMP MODE	▲ A10 LOW AMP MODE

ALL UNUSED SWITCHES SHOULD BE OFF

PUMP BEHAVIOR	A5	A9	PUMP 1 SPEED
ND CIRC PUMP	OFF	OFF	2 SPEEDS
FILTER/ROLLS ONLY	DN	DN	1 SPEED
24HR 3F SHUT-OFF	OFF	DN	1 SPEED
24HR 3F SHUT-OFF	DN	DN	2 SPEEDS

POWER CONNECTION	AC SERVICE	WIRE (A) WHITE	WIRE (B) BLUE	WIRE (C) BLACK
L1 to 3, N1 to 4	230V 1φ / 1x16A-32A	J26 TO J32	J58 TO J68	TO J25*
L1 to 3, N1 to 4, L2 to 1, N2 to 2	230V 1φ / 1x16A-32A	REMOVE	J58 TO J68	TO J25*
N to 4, L1 to 3, L2 to 2, L3 to 1	400V 3φ / 3x16A	REMOVE	REMOVE	TO J25*

* WIRE ORIGINATION FROM AN OPTIONAL EXPANDER BOARD
** ONLY WITH OPTIONAL EXPANDER BOARD

LOCATION	DEVICE
J23	NETZSTROMWENIGUNG 2-GESCHW.-PUMPE 1 ALIMENTATION PUMPE 1 A 2 VITESSES 2-SPEED PUMP 1
J47	AV
J50	KREISLAUF PUMPE POMPE DE CIRCULATION CIRC PUMP
J29	OZONGENERATOR GENERATOROZONE OZONE GENERATOR
J20	BELEUCHTUNG ECLAIRAGE BAIN HYDRO SPA LIGHT

Figure 14

Startup

Important – Read these step-by-step startup procedures before starting your swim spa. Failure to follow any of these steps listed may result in damage to the equipment and may void your warranty.

Note: If you are unsure of any of the above startup procedures, please call our customer care center at 727.573.9611. For best results, read each step in its entirety before proceeding.

⚠ Caution: Running the swim spa pump dry (without water running through it) can cause IMMEDIATE damage and will void the warranty! Be sure that the swim spa is installed properly in accordance with the instructions in this manual.

Refer to the following picture for an explanation of your swim spa's controls, components, and technical terms. Note that not all models have all features and components.

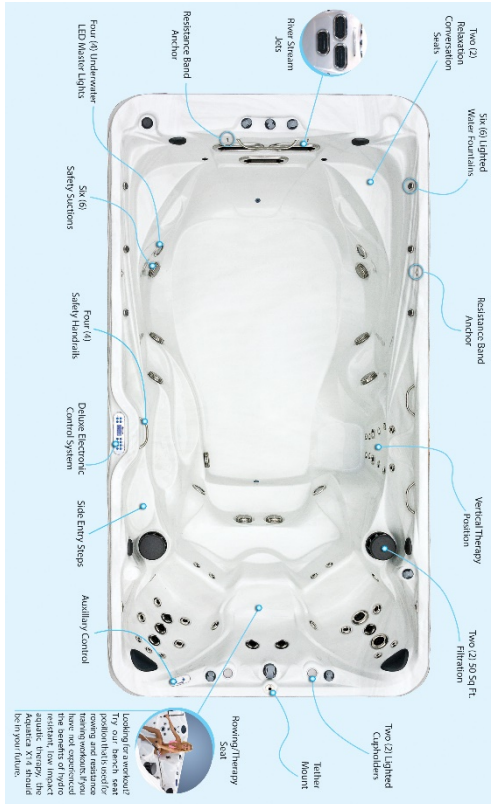

Figure 15 – Swim spa Callouts (AQ 14 Shown)

Before Adding Water

Before adding water, go through these simple steps now to prevent common issues when setting up your swim spa for the first time. Verify that the following have all been rechecked.

1. Turn off all power to the swim spa at the main breaker panel.
2. Open the side panels to access the internal components.
3. Check that all slide valves are opened (T-handles pulled out) to the heater and all pumps.
4. Check that there are no obvious signs of loose wires or broken pipes.

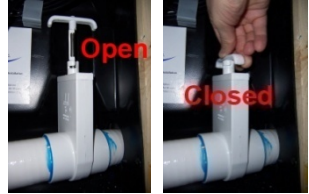

Figure 16 - Valve Open/Closed

5. Check that the two heater unions are hand tight.



Caution: Do not use a wrench. Over-tightening may cause damage to unions and gaskets, which will not be covered under warranty.



Figure 17 - Unions Tight

6. Check that the unions on all pumps are tight.
7. Clean out any foreign debris from within the service access area or inside of the swim spa itself.
8. With the drain open and filters removed, thoroughly rinse out the swim spa with warm water until the drained water runs clear. Run water through the filtration canister and jet lines to remove any incidental dust, dirt, and debris that may have accumulated during shipment or installation. Drain all water completely.
9. Make sure that the swim spa drain valve is closed and the cap is on tight (see page 51).
10. Install the filter(s) in the filtration canister.
11. Check that all of the swim spa jets are open (turned full counter-clockwise).
12. Now is the best time to clean and polish the surfaces of your swim spa (see page 53).

Filling Your Swim spa

Now it's time to fill your swim spa with water. Do not turn on the electricity yet until the swim spa is completely filled. To properly fill your swim spa:

1. Make sure that the filters (in the filtration canister) are gently screwed into place. Turn them clockwise until they stop being careful not to over-tighten them (this avoids cracking the filter).
2. Connect a standard garden hose to a faucet with regular cold tap water (not softened water or hot water).



Figure 18 – Filtration Canister

⚠ Caution: The water from your hot water tank should not be used to fill the swim spa.

3. Put the pre-filter (if equipped*) on the other end of the hose, point the pre-filter into a suitable drain, turn on the water, and allow any sediment to be flushed down the drain. Once the water stream runs clear, turn off the hose.
4. Put the pre-filter (if equipped) into the filtration canister and turn on the hose.
5. **Fill slowly.** If too much water pressure is used, foaming water can force air into the pipes and cause startup problems.

Important: To assure that the pump is properly primed, **fill the swim spa through the filter area only.**

6. Fill the swim spa until the water level is about 1" above all jets (or about ½" below the pillow). Do not over fill.

Note: Every person entering a swim spa displaces a given volume of water, so adjust water level to the number of people regularly using the swim spa. Turn off the hose and check again for any small leaks.

7. On dual zone swim spa it is recommended that swim side be filled first and then the spa side.

See balanced water chart on page 29.

Draining Your Swim Spa

We recommend draining your water every 6-12 months.

1. When draining the dual zone swim spa always drain the spa side before the swim side.
2. Locate nearest drain facility (laundry tub, floor drain, lawn, shower, etc).
3. Turn off the breaker(s) to swim spa and disconnect electrical power to all equipment.

* Pre-filters are available by calling 877.530.PARTS

4. Remove the filter cartridge(s) from swim spa filters.
5. Locate the drain valve at the side of your swim spa cabinet.
6. Attach a garden hose to the drain-valve(s), open the drain-valve and drain swim spa.
7. Monitor the swim spa while it drains.
8. Use another garden hose to wash down interior surface as the swim spa continues to drain.
9. Completely flush the old water from plumbing lines, allow fresh water to fill into foot well area while the old water continues to be drained. When the water from the drain hose turns clear close drain-valve.

Note: For faster draining, you may use a sump pump or siphon.

Operational Checking Your Swim Spa

 **Caution:** Do not turn on any pump until your swim spa is properly filled with water. Running any pump without water in your swim spa can cause IMMEDIATE damage, which is not covered under warranty!

By now you have rechecked your swim spa's mechanical connections and filled it with water to about 1" above all jets by adding cold tap water through the pre-filter (if equipped). Turn on power to the swim spa at the main breaker panel and test the operation of the electrical system. If you encounter a problem, please reference the troubleshooting guide on page 49.

Before applying voltage to power-up your swim spa, it is very important that you understand the sequence of events that occur when the system is activated in order that pumps can be primed efficiently and damage can be avoided.

1. Turn on the breaker and test the swim side operation of the Ground-Fault Circuit Interrupter (GFCI) breaker by pushing the small button. This should automatically trip the swim spa's circuit breaker.

 **DANGER:** If this breaker does not trip, immediately call your electrician. Do not use your swim spa!

Only if pushing this button successfully trips this circuit breaker should you reset this breaker and proceed to the next step.

For swim spas with two electrical services to make sure to test both GFCIs.

2. Turn on power to the swim spa. If your spa is equipped with two electrical supplies, make sure that they are both turned on.
3. The swim spa will go through its priming mode. Go to the topside control panel and follow the control instructions for your particular model swim spa to activate the pumps. All swim spa first goes into a 6-minute Priming mode, indicated by "Pr" message on display. Water heating is disabled during priming. The purpose of the priming mode is to help insure that jet pumps have been primed with water and ready to operate. It may be necessary in some instances to bleed air from the jet pumps in your swim spa if after priming mode the swim spa pumps run but do not move water. The pump may have an air lock. To exit Priming mode and begin normal swim spa operation, press "Up" or "Down" button. The circulation pump starts and

water flows through the jet returns.

4. After energized each of swim spa pump (see for details Topside controls and Operation of each Spa model) you should hear the pump turn on high speed and water circulating through one of River jet of swim spa.

⚠ Caution: If water is not flowing from the jets after 2 minutes, turn the power off at the main panel and bleed air from the system (page 47). Turn the power on again. Sometimes momentarily turning the pump off/on will help to prime. Only do this no more than 4 times.

5. If the water is running smoothly through the lines, open the air control valve to the jets and you should see an increase in jet pressure. Check and adjust the water and airflow of every river jet if necessary.

An air mixture intensifies the level of your current. Turn the air control valve counterclockwise to increase the air mixture and clockwise to turn it off.

To minimize heat loss, close the air control valve when the swim spa is not in use.

6. Repeat same procedure with the therapy pump located on spa side (see for details Topside controls and Operation of each Spa model).

7. You should hear the pump turn on low speed and water start circulating through therapy jets of spa.

8. If the water is running smoothly through the lines, open the air control valve to the jets and you should see an increase in jet pressure. Check and adjust the water and airflow of every river jet if necessary.

An air mixture intensifies the level of your current. Turn the air control valve counterclockwise to increase the air mixture and clockwise to turn it off.

To minimize heat loss, close the air control valve when the swim spa is not in use.

9. Turn therapy pump on high speed (see for details Topside controls and Operation of each Spa model). Verify the water flow circulating through the therapy jets of spa. If the water is running smoothly through the lines, open the air control valve to the jets and you should see an increase in jet pressure. Check and adjust the water and airflow of every jet if necessary.

Each hydrotherapy jet in the spa side can be adjusted for massage intensity and directional flow. Turn the outer jet dial counterclockwise to increase the water volume and clockwise to turn it off. Pivot the angle of a jet to achieve an optimal massage.

An air mixture intensifies the level of your massage. Turn the air control valve counterclockwise to increase the air mixture and clockwise to turn it off.

To minimize heat loss, close the air control valve when the swim spa is not in use.

10. Your swim spa water will heat approximately 1° per hour, on average. Times may vary.
11. Adjust water chemistry according to the Water balancing section

Water Balancing

Once your swim spa reaches 95°F, use our *Bromine Test Strips* (not included) and add the necessary chemicals (not included) to stabilize your water chemistry. Turn Pump 1 on high speed before starting your tests to distribute chemicals evenly. Wait 5 minutes between measurements to allow added chemicals to mix thoroughly.

Important: Test the condition of your water in the following order:

1. **Total Alkalinity** (80-120 ppm) – Use our *Alkalinity Increaser* to raise total alkalinity and *Alkalinity Decreaser* to lower it. Low total alkalinity has little buffering capacity making the pH erratic. High total alkalinity has too much buffering capacity making the pH difficult to change.
2. **pH** (7.2-7.8) – Use *Spa Up* to raise the pH level and *Spa Down* to lower it.
 **Caution:** A pH lower than 7.2 can harm the metal surfaces of your swim spa and irritate your eyes and skin. A pH higher than 7.8 can create calcium deposits (scaling) on the shell and equipment.
3. **Hardness** (150-400 ppm) – Add *Increase Calcium* until the proper level is achieved. Unfortunately, there is no practical way to lower the native water hardness other than using a different source of water when filling your swim spa. Low hardness causes equipment corrosion and water foaming.
4. **Sanitizer** (3.0-5.0 ppm) – Use our *Deluxe Bromine Kit* to add Bromine until the proper level is achieved. Neglected swim spa water can breed bacteria and algae causing bather discomfort, skin rashes, and/or irritation.

Test	Range
Total Alkalinity	80-120 ppm
pH	7.2-7.8
Calcium Hardness	150-400 ppm
Sanitizer	3.0-5.0 ppm

Table 2 - Recommended Ranges for Balanced Water

Note: Perform water balancing weekly and whenever you change water (or when the swim spa is first filled) to ensure proper water condition.

Topside Controls & Operation



ML900 Topside Control Panel

US/Canada: used with controller PEL2SWIM (wiring diagram, page 15)

Export: used with controller PGL2P3P4 (wiring diagram, pages 20, 21)

The topside control panel operates and programs your swim spa. Basic button functions are described next.

When your swim spa is first time actuated, it will go into Priming mode, indicated by "Pr". The Priming mode will last for less than 6 minutes (press "Warm" or "Cool" button to skip Priming Mode. And then the swim spa will begin to heat and maintain the water temperature in the Standard mode.

Main Control Panel ML900

Legend:

 Heat icon: Indicates different stages of heating

 Jets icon: Spins fast on high speed; spins slow on low speed

 Light icon: Light is on/off

F1, F2 indicators: Filter cycle 1 or 2 will be illuminated

PL, TL indicators: Locking Panel or Set Temperature will be illuminated

Temperature Up/Down Buttons

Press the Arrow "Warm" or Arrow "Cool" buttons once to display the set temperature. Each time either button is pressed again, the set temperature will increase or decrease depending on which button is pressed. After three seconds, the LCD display will automatically display the current temperature the hot tub water.

Mode Button

This button is used to switch between **Standard**, **Economy** and **Sleep** modes. Press "Mode" to enter mode programming, press "Cool" through to desired mode (LCD flashes until confirmed), then press "Mode" to confirm selection.

Standard mode maintains the spa water to the set temperature. The “Std” icon will display until the mode is changed.

Economy mode heats the spa water to the set temperature only during filter cycles. The “Ecn” icon will display until mode is changed. Press “Jets 1” button while in Economy mode to place the spa in “Standard-In-Economy mode,” which operates the same as Standard mode, and then reverts to Economy mode automatically after one hour. During this time, a press of the “Mode” button will revert to Economy mode immediately.

Sleep Mode heats the spa to within 20°F (11° C) of the set temperature only during filter cycles. “SLP” will display until mode is changed.

Standby Mode: Pressing “Warm Arrow Up” or “Cool Arrow Down” then “Jets2” button will turn off all spa functions temporarily. This is helpful when changing filter cartridges. Press any button to exit Standby mode.

Jets 1/Swim 1 Button

Press the “Jets 1”/“Swim 1 ” button once to turn pump 1 on or off, and to shift between low and high speeds. If left running, the low speed turns off after two hours and high speed turns off after 15 minutes.

Jets 2-4/Swim 2-4 Buttons (If Equipped)

Press the “Jets 2-4”/“Swim 2-4” buttons once to turn each of pumps 2-4 on or off. If left running, the pumps 2-4 turns off after 15 minutes.

Stir/Swim All Button

Press the “Stir”/“Swim All” button once to turn pumps 2-4 on or off together. If left running, the pumps 2-4 turns off after 15 minutes.

“Aux”/“Option” Button (if Equipped)

Press the “Aux” button once to turn blower on or off (if equipped). If left running, the blower turns off after 15 minutes.

“Lights” Button

Press the “Lights” button to turn the spa light system on and off. The LED light system is preprogrammed with an assortment of lighting effects. When you turn Lights off and turn on again within five (5) seconds, it advances to the next effect. When you turn Light off for more than five (5) seconds, it remembers that last effect you selected. The next time you turn on the Light will display the same effect. The Light will automatically turn off after approximately four (4) hours.

Setting the Time

Once your spa has been properly connected the first time the “Time” icon appearing on the screen and flashing. Press “Time” pad, then “Mode.” Select the hour by pressing “Warm” or “Cool” (each press changes time by 1 hour). Press “Mode” pad again and select minutes by pressing “Warm” or “Cool” (each press changes time by 1minute). Press “Mode” pad to exit the time setting procedure and enter the optional filter cycle programming. Press “Time” pad to exit programming. The Time setting on this system is preserved in the event of power

loss.

Invert Display

Press “Invert” button to change the direction of information on the display.

Circulation Pump Operation (if equipped)

Your system is equipped with a circulation pump. The circulation pump provides 24-hour continuous water circulation and filtration. The circulation pump turns over the entire spa water capacity at a minimum of one time every hour (depending on water capacity). It works like this: a dedicated, energy efficient circulation pump constantly draws water from the spa, runs it through the filter 1 and the heater (heating only when necessary), then back to the spa. The ozone output is on whenever the circulation pump is running. The Circulation pump will turn off for 30 minutes at a time when the water temperature reaches 3°F (1.5°C) above the set temperature (most likely this will happen in a very hot climate or during summer).

Heater Operation

Your spa is equipped with an electrical heater. By setting your thermostat to the desired temperature, your heater will automatically turn on and off as needed. The temperature set point (set temperature) can be adjusted from 70°F to 104°F/21°C-40°C. To raise the set temperature press the “Warm Arrow Up” button. To lower the set temperature, press the “Cool Arrow Down” button. The startup temperature is set at 100°F/37.5°C. The last measured temperature is constantly displayed on the LCD. In Economy mode the heater heats the spa water only during filter cycles. In sleep mode the heater heats the spa water to within 20°F (11°C) of set temperature only during filter cycles.

Filter Cycle Programming

Additional water circulation, filtration and ozonation (filter 2) added to spa system. Two speeds pump 1(Low) running during pre-programmed filtration cycles.

At the start of each filter cycle the blower (if equipped) will run for 30 seconds; and the pump 1 (low) and, if equipped, pumps 2-4 (high) will run for 30 seconds to prevent the spa water from becoming stagnant in the plumbing and air lines and improve skimming action to remove debris and suspensions from the water surface.

Your spa came programmed from the factory with these defaults. The first filter cycle is automatically activated at 8 a.m. and operates the pump 1 until 10 a.m. The filter indicator icon on display will light when filter 1 cycle is running.

The second filter cycle is automatically activated at 8 p.m. and operates the pump 1 until 10 p.m.. The filter indicator icon will light when filter 2 cycle is running. To program custom filter cycle setting, press “Time”+“Mode/Prog” button+“Mode/Prog”+“Mode/Prog” within 3 seconds. The Program, Filter 1, Filter 2, and Start Time icons will appear on the display. Press “Warm” or “Cool” button to choose the Filter 1 start time hour. Each press changes the start time by 5 minutes. Press “Mode/Prog” button to enter minutes. Press “Mode/Prog” to see the Program, Filter 1, and End time icons. Adjust time as done above.

Press "Mode/Prog" button to see the Program, Filter 2, and Start time icons. Proceeds as above. Press "Mode/Prog" button to see the Program, Filter 2, and End time icons. Adjust time as previously stated.. Press "Mode/Prog" button again to enter the new filter time setting in system and display the current water temperature. Press "Time" button at any time during this programming sequence to save the values entered up to that point and exit programming.

Ozone System

Your spa is equipped with two ozone purification systems (only Deluxe models). You will find that your spa water stays fresh and clear with significantly less chemical sanitizer usage. You will be able to go longer between complete spa draining. The ozone generator 1 operates in conjunction with the circulation pump and ozone generator 2 running with two speeds pump 1 at low speed in programming filtration cycles. Ozone generator 1 is on any time the circulation pump is running.

Freeze Protection

If the temperature sensor detects a temperature drop to 44°F (6.7°C) within the heater, then the pump automatically activates to provide freeze protection. The equipment stays on until four (4) minutes after the sensors detect that the spa water temperature has risen to 45°F (7.2°C) or higher. In colder climates, an optional additional freeze sensor may be added to protect against freeze condition that may not be sensed by the standard sensors. Auxiliary Freeze sensor protection acts similarly except with the temperature thresholds determined by the switch and without a four (4) minute delay in turnoff. See your dealer for details.

Locking the Panel

Press "Time", "Jets 1" then "Warm Arrow Up" buttons within three (3) seconds. When locked, the "PL" indicator light will light. All buttons are frozen except the "Time" button. To unlock the panel, press "Time", "Jets 1" then "Cool Arrow Down."

Locking the Temperature Setting

Press "Warm Arrow Up" or "Cool Arrow Down" then "Time," "Jets 1," and "Warm Arrow Up" buttons within three (3) seconds to activate lock. When locked, the "TL" indicator light will light when the set temperature is locked. To unlock the set temperature, press "Warm Arrow Up" or "Cool Arrow Down" then "Time", "Jets 1," and "Cool Arrow Down."

Swim spa control power limitations

The swim spa and spa protected 60A GFCI (maximum spa load should not exceed 48A).

The swim spa control deactivate heater if any High speed pump is running.

The swim spa control allows only three High speed pumps running at same time.

Auxiliary panel AX20 (only if equipped)

Auxiliary panel AX20 typically installed on spa side. Press the “Jets” button once to turn pump 1 on or off, and to shift between low and high speeds. If left running, the low speed turns off after two hours and high speed turns off after 15 minutes.

Press the “Light” button to turn the spa light system on and off.



ML700 Top Side Control Panel

US/Canada: used with controller PEL2SWIM (wiring diagram, page 15)

US/Canada: used with controller PEL2P3S2 (wiring diagram, page 16)

Export: used with controller PGL2P3P4 (wiring diagram, pages 20, 21)

The topside control panel operates and programs your swim spa. Basic button functions are described next.

When your swim spa is first time actuated, it will go into Priming mode, indicated by “Pr”. The Priming mode will last for less than 6 minutes (press “Warm” or “Cool” button to skip Priming Mode. And then the swim spa will begin to heat and maintain the water temperature in the Standard mode.

Jets 1 Button

Press the “Jets 1” button once to turn pump 1 on or off, and to shift between low and high speeds. If left running, the low speed turns off after two hours and high speed turns off after 15 minutes.

Jets 2-3 Buttons

Press the “Jets 2, 3” buttons once to turn each of pumps 2,3 on or off and shift between low and high speeds. If left running, the low speed turns off after two hours and high speed turns off after 15 minutes.

Light Button

Press the “Light” button to turn the spa light system on and off. The LED light

system is preprogrammed with an assortment of lighting effects. When you turn Light off and turn on again within five (5) seconds, it advances to the next effect. When you turn Light off for more than five (5) seconds, it remembers that last effect you selected. The next time you turn on the Light will display the same effect. The Light will automatically turn off after approximately four (4) hours.

Circulation Pump Operation (if equipped)

Your system is equipped with a circulation pump. The circulation pump provides 24-hour continuous water circulation and filtration. The circulation pump turns over the entire spa water capacity at a minimum of one time every hour (depending on water capacity). It works like this: a dedicated, energy efficient circulation pump constantly draws water from the spa, runs it through the filter 1 and the heater (heating only when necessary), then back to the spa. The ozone output is on whenever the circulation pump is running. The Circulation pump will turn off for 30 minutes at a time when the water temperature reaches 3°F (1.5°C) above the set temperature (most likely this will happen in a very hot climate or during summer).

Heater Operation

Your spa is equipped with an electrical heater. By setting your thermostat to the desired temperature, your heater will automatically turn on and off as needed. The temperature set point (set temperature) can be adjusted from 70°F to 104°F/21°C-40°C. To raise the set temperature press the “Warm Arrow Up” button. To lower the set temperature, press the “Cool Arrow Down” button. The start up temperature is set at 100°F/37.5°C. The last measured temperature is constantly displayed on the LCD. In Economy mode the heater heats the spa water only during filter cycles. In sleep mode the heater heats the spa water to within 20°F (11°C) of set temperature only during filter cycles.

Filter Cycle Programming

Additional water circulation, filtration and ozonation (filter 2) added to spa system. Two speeds pump 1(Low) running during pre-programmed filtration cycles.

At the start of each filter cycle the blower (if equipped) will run for 30 seconds; and the pump 1 (low) and, if equipped, pumps 2-4 (high) will run for 30 seconds to prevent the spa water from becoming stagnant in the plumbing and air lines and improve skimming action to remove debris and suspensions from the water surface.

Your spa came programmed from the factory with these defaults. The first filter cycle is automatically activated at 8 a.m. and operates the pump 1 until 10 a.m. The filter indicator icon on display will light when filter 1 cycle is running.

The second filter cycle is automatically activated at 8 p.m. and operates the pump 1 until 10 p.m.. The filter indicator icon will light when filter 2 cycle is running. To program custom filter cycle setting, press “Time+”Mode/Prog” button+”Mode/Prog”+”Mode/Prog” within 3 seconds. The Program, Filter 1, Filter 2, and Start Time icons will appear on the display. Press “Warm” or “Cool” button to choose the Filter 1 start time hour. Each press changes the start time by 5 minutes. Press ”Mode/Prog” button to enter minutes. Press “Mode/Prog” to see the Program, Filter 1, and End time icons. Adjust time as done above.

Press "Mode/Prog" button to see the Program, Filter 2, and Start time icons. Proceeds as above. Press "Mode/Prog" button to see the Program, Filter 2, and End time icons. Adjust time as previously stated.. Press "Mode/Prog" button again to enter the new filter time setting in system and display the current water temperature. Press "Time" button at any time during this programming sequence to save the values entered up to that point and exit programming.

Ozone System

Your spa is equipped with two ozone purification systems (only Deluxe models). You will find that your spa water stays fresh and clear with significantly less chemical sanitizer usage. You will be able to go longer between complete spa draining. The ozone generator 1 operates in conjunction with the circulation pump and ozone generator 2 running with two speeds pump 1 at low speed in programming filtration cycles. Ozone generator 1 is on any time the circulation pump is running.

Freeze Protection

If the temperature sensor detects a temperature drop to 44°F (6.7°C) within the heater, then the pump automatically activates to provide freeze protection. The equipment stays on until four (4) minutes after the sensors detect that the spa water temperature has risen to 45°F (7.2°C) or higher. In colder climates, an optional additional freeze sensor may be added to protect against freeze condition that may not be sensed by the standard sensors. Auxiliary Freeze sensor protection acts similarly except with the temperature thresholds determined by the switch and without a four (4) minute delay in turnoff. See your dealer for details.

Locking the Panel

Press "Time", "Jets 1" then "Warm Arrow Up" buttons within three (3) seconds. When locked, the "PL" indicator light will light. All buttons are frozen except the "Time" button. To unlock the panel, press "Time", "Jets 1" then "Cool Arrow Down."

Locking the Temperature Setting

Press "Warm Arrow Up" or "Cool Arrow Down" then "Time," "Jets 1," and "Warm Arrow Up" buttons within three (3) seconds to activate lock. When locked, the "TL" indicator light will light when the set temperature is locked. To unlock the set temperature, press "Warm Arrow Up" or "Cool Arrow Down" then "Time", "Jets 1," and "Cool Arrow Down."

Swim spa control power limitations

The swim spa and spa protected 60A GFCI (maximum spa load should not exceed 48A).

The swim spa control deactivate heater if any High speed pump is running.

The swim spa control allows only three High speed pumps running at same time.

Auxiliary panel AX20 (only if equipped)

Auxiliary panel AX20 typically installed on spa side. Press the “Jets” button once to turn pump 1 on or off, and to shift between low and high speeds. If left running, the low speed turns off after two hours and high speed turns off after 15 minutes.

Press the “Light” button to turn the spa light system on and off.

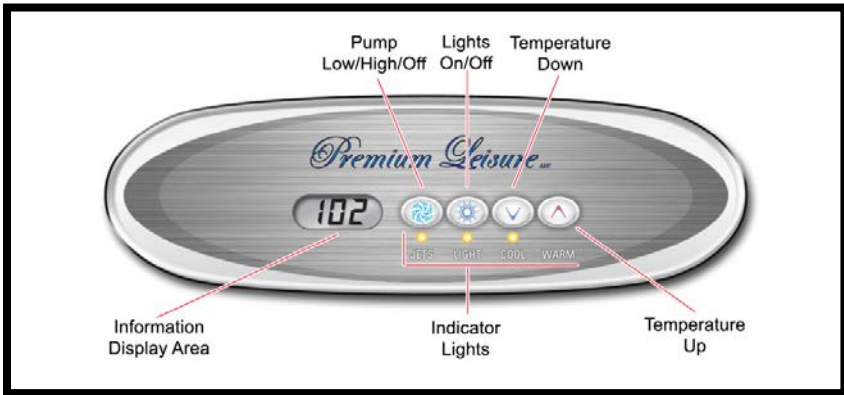

MVP 260 Top Side Control Panel

US/Canada: used with controller VS500Z (wiring diagram, page 18),
controller VS515Z (wiring diagram, page 19).

Export: used with controller GS500Z (wiring diagram, page 23).

The topside control panel operates and programs your swim spa.

Basic button functions are described next.

When your swim spa is first time actuated, it will go into Priming mode, indicated by “Pr.” The Priming mode will last for less than 6 minutes (press “Warm” or “Cool” button to skip Priming Mode). And then the swim spa will begin to heat and maintain the water temperature in the Standard mode.

Initial Start Up

When your swim spa is first actuated, it will go into Priming mode, indicated by “Pr.” The priming mode will last for less than five minutes. Press “WARM” or “COOL” to skip Priming Mode and then the swim spa will begin to heat and maintain the temperature in “Standard Mode.”

Warm/Cool Buttons (Set Temperatures between 80°F - 104°F / 26°C - 40°C)

The startup temperature is set at 100°F/37°C. The last measured temperature is constantly displayed on the LCD and is current only when the pump has been running for at least two minutes. To **display** the set temperature, press the “WARM” or “COOL” button once. To **change** the set temperature, press the “WARM” or “COOL” button a second time before the LCD stops flashing. Each press of the “WARM” or “COOL” button will continue to raise/lower the set

temperature. After three seconds, the LCD will stop flashing and display the current swim spa temperature.

Jets Button

Press the "JETS" button once to activate the low speed of Pump 1. Press it a second time to activate the high speed of Pump 1. Press it a third time to turn off Pump 1. If left running, the high speed of Pump 1 automatically will turn off after 15 minutes and the low speed of Pump 1 automatically will turn off after 4 hours.

The low speed of Pump 1 may be active for at least two minutes every half hour to detect the swim spa temperature and then to heat to the set temperature if needed (depending on mode). When the low speed turns on automatically, it cannot be deactivated from the panel, however the high speed may be activated.

Light

Press the "LIGHT" button once to turn on your swim spa lights. Press the LIGHT button multiple times to cycle through the many available color patterns. Press the LIGHT button again to turn off the LED light system. If left on, the lights automatically turn off after 4 hours.

Mode

Your swim spa operating mode is changed by first pressing the "WARM" or "COLD" button, then pressing the "LIGHT" button.

- **Standard Mode** is programmed to constantly maintain the desired temperature. "St" will be displayed momentarily when you switch into standard mode.
- **Economy Mode** heats the spa to the set temperature *only* during filter cycles. "Ec" will display solid when temperature is not current and will alternate with temperature when temperature is current.
- **Sleep Mode** heats the swim spa to within 20°F/10°C of the set temperature *only* during filter cycles. "SL" will display solid when temperature is not current and will alternate with temperature when temperature is current.

Preset Filter Cycles

The first filter cycle begins six minutes after the swim spa is energized. The second filter cycle begins 12 hours later. Filter duration is programmable for 2, 4, 6 or 8 hours – or for continuous filtration indicated by "FC". The default filter time is two hours.

To program filter cycles, press "WARM" or "COOL" and then "JETS." Press "WARM" or "COOL" again to adjust to your desired setting. Press "JETS" again to exit filter cycle programming.

The low speed of the 2-speed pump runs during filtration and the ozonator will be enabled.

For 24 hour circulation systems the circulation pump and ozone generator run 24 hours. In hot environments the circulation pump will turn off for 30 minute periods, except during filter cycles.

Smart Winter Mode



If the system (sensor located inside heater) detects ambient conditions below 44°F/6.7°C, it automatically enters the Smart Winter Mode for period of four minutes after it detects the swim spa temperature has risen to 45°F/7.2°C.

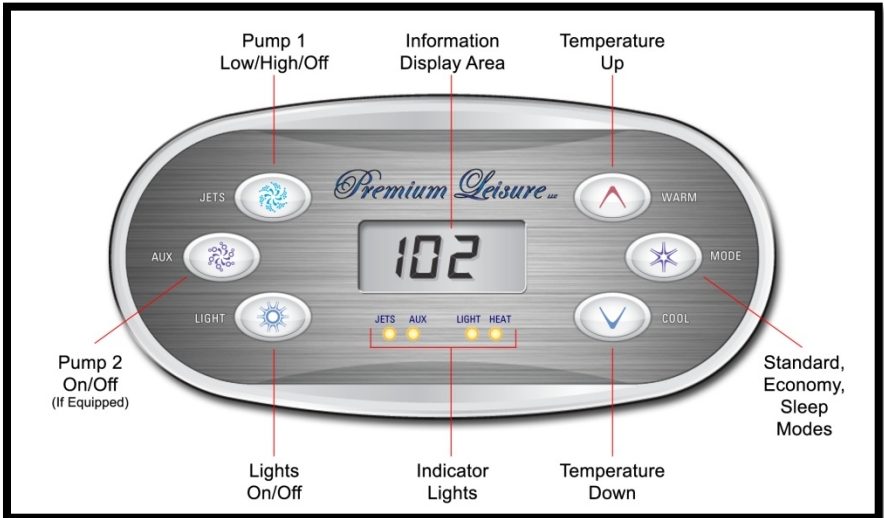

VL 600S Top Side Control Panel

US/Canada: used with controller VS510SZ-AQ 10(wiring diagram, page 17),

Export: used with controller GS510SZ (wiring diagram page 22).

The topside control panel operates and programs your swim spa. Basic button functions are described next.

When your swim spa is first time actuated, it will go into Priming mode, indicated by "Pr." The Priming mode will last for less than 6 minutes(press "Warm" or "Cool" button to skip Priming Mode. And then the swim spa will begin to heat and maintain the water temperature in the Standard mode.

Initial Start Up

When your swim spa is first actuated, it will go into Priming mode, indicated by "Pr." The priming mode will last for less than five minutes. Press "WARM" or "COOL" to skip Priming Mode and then the swim spa will begin to heat and maintain the temperature in "Standard Mode."

Warm/Cool Buttons (Set Temperatures between 80°F - 104°F / 26°C - 40°C)

The startup temperature is set at 100°F/37°C. The last measured temperature is constantly displayed on the LCD and is current only when the pump has been running for at least two minutes. To **display** the set temperature, press the “WARM” or “COOL” button once. To **change** the set temperature, press the “WARM” or “COOL” button a second time before the LCD stops flashing. Each press of the “WARM” or “COOL” button will continue to raise/lower the set temperature. After three seconds, the LCD will stop flashing and display the current swim spa temperature.

Jets Button

Press the “JETS” button once to activate the low speed of Pump 1. Press it a second time to activate the high speed of Pump 1. Press it a third time to turn off Pump 1. If left running, the high speed of Pump 1 automatically will turn off after 15 minutes and the low speed of Pump 1 automatically will turn off after 4 hours.

The low speed of Pump 1 runs when the “AUX” Pump 2 (if equipped) is on. It may also active for at least two minutes every half hour to detect the swim spa temperature and then to heat to the set temperature if needed (depending on mode). When the low speed turns on automatically, it cannot be deactivated from the panel, however the high speed may be activated.

Aux Button

Press the “AUX” button once to turn on Pump 2 (if equipped). Press it a second time to turn off Pump 2. If left running, Pump 2 automatically will turn off after 15 minutes.

Light

Press the “LIGHT” button once to turn on your swim spa lights. Press the LIGHT button multiple times to cycle through the many available color patterns. Press the LIGHT button again to turn off the LED light system. If left on, the lights automatically turn off after 4 hours.

Mode

Your swim spa operating mode is changed by first pressing the “WARM” or “COLD” button, then pressing the “MODE” button.

- **Standard Mode** is programmed to constantly maintain the desired temperature. “*Std*” will be displayed momentarily when you switch into standard mode.
- **Economy Mode** heats the spa to the set temperature *only* during filter cycles. “*Ecn*” will display solid when temperature is not current and will alternate with temperature when temperature is current.
- **Sleep Mode** heats the swim spa to within 20°F/10°C of the set temperature *only* during filter cycles. “*SLP*” will display solid when temperature is not current and will alternate with temperature when temperature is current.
-

Preset Filter Cycles

The first filter cycle begins six minutes after the swim spa is energized. The second filter cycle begins 12 hours later. Filter duration is programmable for 2, 4, 6 or 8 hours – or for continuous filtration indicated by “*FLC*.” The default filter time is two hours.

To program filter cycles, press “WARM” or “COOL” and then “JETS.” Press “WARM” or “COOL” again to adjust to your desired setting. Press “JETS” again to exit filter cycle programming.

The low speed of the 2-speed pump runs during filtration and the ozonator will be enabled.

For 24 hour circulation systems the circulation pump and ozone generator run 24 hours. In hot environments the circulation pump will turn off for 30 minute periods, except during filter cycles.

Smart Winter Mode



If the system (sensor located inside heater) detects ambient conditions below 44°F/6.7°C, it automatically enters the Smart Winter Mode for period of four minutes after it detects the swim spa temperature has risen to 45°F/7.2°C.

Programming Summary

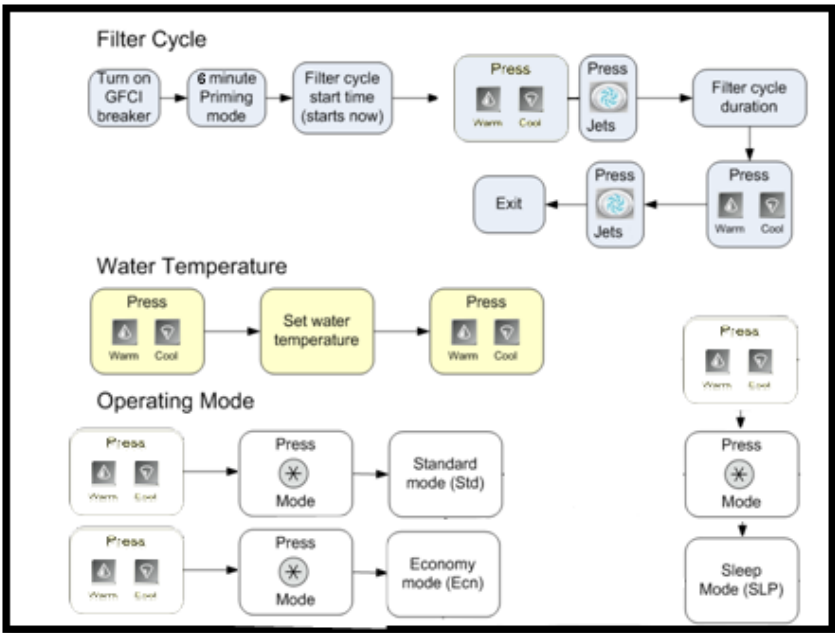

Figure 19 – VL600S Programming Summary

NOTE: FOR ALL SWIM SIDE EQUIPPED WITH MVP 260 PANEL:

- Follow the above steps to set the filter cycle and water temperature.
- To set the operating modes, follow the steps above *except* instead of pressing "Mode" – press "LIGHT."

Error Codes (All Spa Panels)

MESSAGE	MEANING	ACTION REQUIRED
<i>(none)</i>	No message on display. Power has been cut off to hot tub.	The control panel is disabled until power returns. Hot tub settings are preserved.
OHH HH	The hot tub has shut down from high heat detection. One of the sensors detected 118°F (48°C) at the heater.	Do not enter the water. Remove the cover and allow the water to cool. Once cool, push any button. If the hot tub does not reset, turn off the GFCI and call service.
OHS OH	The hot tub has overheated and shut down. One of the sensors detected that the hot tub water is 110°F (43°C).	Do not enter the water. Remove the cover and allow the water to cool. At 107°F (42°C), the hot tub resets automatically. If the hot tub does not reset, turn off the GFCI and call service.
ICE IC	Potential freeze condition detected (Ice)	No action required. The pump will automatically operate regardless of the hot tub status.
SnA SA	Sensor A is not working correctly. Hot tub is shut down.	Check the sensor "A" plug connection to circuit board. The problem may appear temporarily in an overheat situation and disappear when the heater cools. If the problem persists, contact service.
SnB SB	Sensor B is not working correctly. Hot tub is shut down.	Check the sensor "B" plug connection to circuit board. The problem may appear temporarily in an overheat situation and disappear when the heater cools. If the problem persists, contact service.
SnS Sn	Sensors are out of balance.	If this alternates with the temperature, it may be temporary. If the display shows only this message (periodically blinking), the hot tub is shut down. If the problem persists, contact service.
HFL HL	A substantial difference between sensors was detected (possible flow problem).	Check water level in hot tub and add water if necessary. Be sure that slide-valves are open. Make sure the pump is primed and has power. If the problem persists, contact service.

MESSAGE	MEANING	ACTION REQUIRED
LF	<i>Low Flow</i> – persistent problem. Displays after the fifth occurrence of the "HL" message within 24 hours. Heater shuts down but other hot tub functions run normally.	Heating ability of the hot tub will not reset automatically; press any button to reset.
dr	Inadequate water, poor flow, or air bubbles detected in the heater. Hot tub is shut down for 15 minutes.	Check the water level and add water if necessary. Be sure that slide-valves are open. Make sure the pump is primed and has power. Press any button to reset (automatically reset within 15 minutes). If the problem persists, contact service.
drY dy	Inadequate water detected in heater. Displays on third occurrence of "dr" message. Hot tub is shut down.	Check water level in hot tub. Add water if necessary. Be sure that slide-valves are open. Make sure the pump is primed and has power. Press any button to reset.
Pr	When the hot tub is first activated, it goes into Priming mode.	The Priming mode runs for up to four minutes and then the hot tub begins to heat and maintain the water temperature in Standard mode.
-- F	Temperature unknown	After the pump has been running for two minutes, the temperature will be displayed.
-- C	Temperature unknown	After the pump runs for two minutes, the temperature displays
---	Temperature not current	The hot tub is in either Economy or Sleep modes and the pump has not run for a while. To view the current temperature, switch to Standard mode or operate Jets 1 for at least one minute.
SbY	Hot tub is in standby mode	Press any button except Jets 1 to leave Standby mode.
PHL	pH is low	Add pH increaser (pH up)
PHH	pH is high	Add pH decreaser (pH down)
SAL	Sanitizer is low	Add sanitizer
SAH	Sanitizer is high	Remove hot tub cover and allow sanitizer to evaporate
drn	Pump is on during Standby mode to assist in draining the water	Press Jets 1 to turn off pump once the water has drained out
rtC	Hardware failure	Contact customer service
PSt	Hardware failure	Contact customer service

MESSAGE	MEANING	ACTION REQUIRED
CrC	Firmware install problem	Contact customer service if this message appears on more than one power up
CFE	Configuration error. Hot tub cannot start up	Contact customer service
9FI	Could not trip GFCI	Contact customer service and do not use the hot tub.
StU	Pump appears to be stuck on	Contact customer service and do not use the hot tub
HOt	Pump was stuck on the last time it was powered on	Contact customer service and do not use the hot tub

Reminder Messages (Only for ML700, ML900 panels)

Message	Frequency	Action Required
rPH	7 days	Test and adjust pH chemical levels.
rSA	7 days	Test and adjust sanitizer chemical levels.
rCL	30 days	Remove, clean, and reinstall filter.
rt9	30 days	Test & reset GFCI breaker.
rdr	90 days	Drain and refill hot tub.
rCO	180 days	Clean and condition cover.
rtr	180 days	Clean and condition exterior surfaces.
rCH	365 days	Install new filter.
rCA	As needed	Install new Mineral cartridge.

Special Operating Instructions

For swim spa equipped with waterfall features.

Turn on waterfall features by pressing “Jets” or “Spa” button on top side panel to energize one or two speed pump running this feature, turn “on-off” valve located on top side of the swim spa and adjust water flow as you desire. Be sure you adjust the water flow when pump running on highest speed to prevent water splashing. With some swim spas the water feature is available only if the diverter valve is set to position when swim spa water diverted to the water features. The diverter valve also located on top side of swim spa.

For swim spa equipped with River Jets (swim jets).

To turn on each jet press Swim1, 2, 3 or Jets 1, 2, 3 buttons. Each jets moves 300-350 GPM of water. To adjust water flow direction move 8” horizontal eyeball nozzle up or down.

Optional Audio and Docking station

MRD85i AM/FM with internal DMD Dock/Stereo Sirius Satellite Ready Marine stereo

MRD85i features DMD Dock, Bluetooth and is an AM/FM/Sirius Satellite Ready stereo with internal docking station for your digital music devices (DMD) like i-Pod, MP3 or Smartphone. Insert your digital music devices and play your music. MRD85i is full featured waterproof marine stereo, waterproof designed, engineered and optimized for spa use. With adjustable backlight display type with flip down face design. SD Card Reader available at the front. USB input available to play your music from a USB Flash drive. Additional AUX Input available at the back. Wireless Remote. Selectable EQ setup so you can select best audio setting for particular speakers. Bluetooth enable.

NOTE: For instructions on how to operate your AM/FM audio system, capabilities and features, see the manufacturer's Operational Manuals (provided).



Figure 20 – Optional MRD85i Stereo

Cover

Place the insulated cover on your swim spa. Keeping the cover in place anytime the swim spa is not in use reduces the heating time and minimizes operating costs. The time required for initial heat-up varies depending on the starting water temperature, ambient temperature, and the capacity of your swim spa.

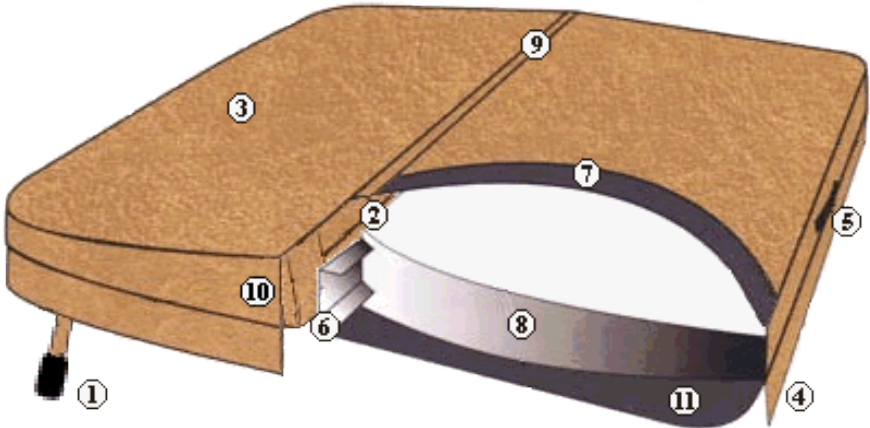

Figure 21 - Cover Callouts

- | | |
|--------------------------------|-------------------------------------|
| 1. Lock-down tab | 7. Heat-sealed insulation |
| 2. Double-stitched seams | 8. Chemical-resistant vapor barrier |
| 3. Marine-grade cover material | 9. Polystyrene seam stoppers |
| 4. Edge overlap material | 10. Reinforced edges |
| 5. Grip handle | 11. Breathable underside material |
| 6. Aluminum channel | |

Use the lock-down tabs to prevent access to the swim spa by children and to prevent the wind from lifting the cover off.



**Figure 22 -
Lockdown Tabs**

Sitting, standing, and snow buildup on the cover will break the cover. Dragging it over rough surfaces will scuff or tear the fabric. Always lift by the handles or use the optional cover lift device.



Figure 23 – Swim Spa Cover Sections for “18” Models

Frequently Asked Questions

Who do I call for warranty information or service?

Call our customer care center between 8 a.m. and 5 p.m. EST Monday through Friday at 727.573.9611. Our representatives are eager to assist or you can get parts and information online at www.HotTubParts.com.

How do I bleed air from my system?

When draining and refilling your swim spa, the pump may become air locked. Air-locked pumps stop water from flowing in your swim spa and is easily resolved by bleeding off the trapped air. To do this:

1. Turn off the GFCI breaker
2. Open the access panel below the topside control panel
3. Loosen a heater union until you hear the trapped air escape
4. Once water drips out in a continuous stream, hand tighten the union until the water stops leaking
5. Loosen the discharge union on Pump (if equipped)
6. Once water drips out in a continuous stream, hand tighten the union until the water stops leaking
7. Turn on all pumps to make sure that there are no leaks
8. Put the access panels back on
9. Turn on the GFCI breaker



Figure 24 - Bleeding Air

What happens when my warranty expires?

Premium Leisure will continue to provide service for your swim spa after your warranty has expired via our customer care center at 727.573.9611.

Where can I get more Chemicals or other accessories?

Visit www.hottubparts.com or call 877.530.PARTS.

How should I clean my swim spa?

Use non-sudsing cleaners and non-oily polishes (Call). Our Citra Bright Spray Cleaner and our Tub Rub cleaning pad quickly removes scum lines and helps restore your shell's original beauty. Rinse all filters, covers, pillows, and surfaces thoroughly with warm tap water. Our Filter Clean concentrated cleanser is a safe, effective way to clean and re-use your filters and our Jet Clean plumbing cleanser cleans the inside of all plumbing in your swim spa. Call 727.573.9611 to order these easy-to-use cleaning products.

How often should I drain my swim spa?

You should drain and refill your swim spa every 6-12 months depending on usage. Every other time you drain and refill, you should also replace the filters and wipe down the swim spa (Call).

How do I adjust my spa jets?

Simply turn the jets counterclockwise to open and clockwise to close. Be careful not to overturn the jets, as damage can occur.

⚠ Caution: Do not turn off too many jets at the same time. This can create backflow and possible damage to your swim spa! Do not attempt to adjust the oval jets on the swim side of the unit.

Are the spa jets removable? Interchangeable? Replaceable?

Most spa jets are made removable and adjustable for customized hydrotherapy. Do not attempt to remove the oval jets on the swim side of the unit.

Troubleshooting

If a problem arises, you can check this list for a quick solution. If this does not resolve your problem, please call our customer care center, at 727.573.9611. Additional information is also available at www.PremiumLeisure.com. You will need your serial number to access this site.

Important – Most problems can be quickly resolved by resetting the GFCI breaker. Try this first before proceeding.

Spa Side Troubleshooting

PROBLEM	CAUSE	SOLUTION
Breaker trips	Wiring error	Load Neutral wire not connected to GFCI (connected to Neutral bus)
	Wrong GFCI	GFCI breaker is wrong size
	Ozonator wet	Remove tube from ozonator and allow 2 days to dry out
Foamy water	Soaps, skin oils, or undissolved sanitizer particles	Close the air control valves and allow filtration cycle to run Add defoamer Drain and clean your swim spa Clean or change filters Rinse all bathing suits before bathing
Leak	Loose connection	Check and hand-tighten unions at heater & pumps, or clamps on jets
	Drain open	Close drain valve or replace cap
Light doesn't Work	LED burnt out	Replace bulb
	Loose wire	Check wiring harness to LED
	Loose plug	Reseat J20 plug on swim spa pack
Low/no jet pressure	Air lock	Bleed air from the system (page 47-48)
	Dirty filter	Check and clean or replace filter
	Closed jets	Open all jets by turning CCW
	Closed valves	Open all T-handle shutoff valves on heater and pumps
	ACV open	Close air control valves
Moved my swim spa and now it doesn't work	Low water	Fill swim spa 1" above all jets
	Wiring error at GFCI	Check Neutral wiring of GFCI (see diagrams on pages 12)
	No power to swim spa	Reset circuit breakers on GFCI panel and main circuit breaker panel
Nothing works	Breaker has tripped	Check and reset breaker. If problem persists, check for loose electrical connections. Check for Neutral wiring error at GFCI.
Pump not running	Fuse blown	Check for blown fuses inside of spa pack.
	No power to swim spa	Reset circuit breakers on GFCI panel and main circuit breaker panel

PROBLEM	CAUSE	SOLUTION
Water does not flow	Air lock Closed jets ACV open	Bleed air from the system (page 47-48) Open all jets by turning counterclockwise Close air control valves
Water too hot	High set temperature High ambient temperature	Turn down set temperature on topside control panel Remove the cover
Water will not heat	Thermostat is set too low Air open Dirty filter Blown fuse Slide valve closed Cover off Swim spa in Economy mode	Check and reset to desired temperature Close air control valve Check and clean filter Check and replace fuse Check and open all valves Put the cover back on Press the Standby button and take out of Economy

Table 5

Maintenance and Care

Important – The warranty on your swim spa and equipment depends on proper sanitation (see page 29). In addition, the following maintenance procedures must be followed periodically.

Cabinets

Your cabinet is made from a polymer that combines the durability of plastic with the beauty of simulated wood. To clean the cabinet, a mild soap and water solution easily removes residue.

Cover

The 5-inch thick tapered cover on your swim spa is made from a weatherproof marine-grade vinyl. It comes in two or three pieces, two that fold in half and one small section for the middle. See page 42 for cover installation information. Your cover will last much longer if you heed the following suggestions:

- 1) Don't drag the cover on the ground; wearing of the vinyl could easily develop into a tear.
- 2) The insulating foam in your cover is not designed to hold the weight of a person or an animal.

Important – Cracked foam in the cover is not covered under warranty! Do not stand on it.

- 3) Occasionally clean the inside of your cover with our special All Purpose Cleaner rinsed with warm water. (Using soap or vinyl cleaners on the inside of your cover causes foamy water.) Call our order line at 727.573.9611 to order our All Purpose Cleaner.
- 4) Our special Vinyl Cover Cleaner applied to the outside of the cover and stitching once yearly will keep your cover looking better longer. Call our order line at 727.573.9611 to order our special Vinyl Cover Cleaner.
- 5) Do not lift the cover by the safety straps, they are made to secure the tub to the cabinet and may tear.

Draining and Refilling



Figure 25 - Drain Operation

- 1) Turn off the GFCI breaker.
- 2) Remove swim spa cover and allow water to cool down.

- 3) Select a safe, suitable drainage area capable of safely assimilating approximately 2,000 gallons of water (7,571 liters) that may contain unsanitary contaminants and chemical residue that could cause harm to plants or grass.
- 4) Locate drain valve at base of the swim spa. Hold the rear body to prevent it from turning, then loosen and remove the front cap.
- 5) Attach a garden hose to the exposed threads and route the hose downhill to your drainage area.
- 6) Twist the drain fitting 1/3 turn counterclockwise to unlock the drain valve and pull it outward to open completely. The water will drain by gravitational flow.
- 7) After the swim spa drains, perform steps 3-5 in reverse order to close the drain prior to refilling swim spa.
- 8) Attach the garden hose to a thoroughly-flushed pre-filter (not included, rinsed of all residual sediment) and refill your swim spa through the filtration canister.
- 9) After refilling, turn on the GFCI breaker to the swim spa.

If the pump runs but no water flows, see page 47-48 to see how to bleed air from the system.

Filters

The filters in your swim spa should be removed and cleaned every 2 weeks with our special Filter Clean concentrated cleanser and typically replaced every 4-6 months (depending upon use). You can clean your filters with the water pressure from the end of a garden hose then rinsed with warm water. This ensures that the water is being filtered properly.

DO NOT USE BLEACH. We recommend having replacement filters on hand that can be swapped between cleanings. Doing so enables you to quickly exchange the dirty filters with clean ones and immediately start your swim spa again. Call our order line at 727.573.9611 to order replacement filters and our special Filter Clean concentrated cleanser.

Spa Jets

Remove and clean the spa jets as needed using our special our Jet Clean plumbing cleanser, water, and a cloth or soft-bristled brush. Call our order line at 727.573.9611 to order our special our Jet Clean plumbing cleanser.

Light

Drain the swim spa and clean the light lens as needed using an optical cloth and an eyewear cleaning product specifically designed not to scratch optical surfaces. If the back side of the lens is also dirty remove the rear panel, remove the light from the holder, and clean in this same manner.

Pillows

Remove and clean the headrest pillows as needed using our Citra Bright Spray Cleaner and our Tub Rub cleaning pad and rinsed thoroughly with warm water. Call our order line at 727.573.9611 to order our Citra Bright Spray Cleaner and our Tub Rub cleaning pad.

Sanitation

Sanitation level is influenced by two factors:

1. Filter Cycle (filtration) time
2. How much you use your swim spa each week

If your water chemistry and water clarity are all proper and your sanitation level is still too low/high, you can adjust the sanitation intensity up/down by adding more/less sanitizer a little at a time and testing the water again after two days.

Shutdown / Winterizing



Your Premium Leisure swim spa is designed to operate year round. If you plan to leave your swim spa unused for long periods of time in severely cold weather, you should winterize your swim spa to avoid accidental freezing due to a power or equipment failure.

We highly recommend that you have a swim spa professional winterize and restart your swim spa.

⚠ WARNING: Damage from improperly winterizing or restarting your swim spa is not covered under your warranty. You can call our customer care center, at 727.573.9611 for recommended service organizations to assist you in properly winterizing your swim spa.

Surface

The acrylic surface of your swim spa should be cleaned with our Citra Bright Spray Cleaner and our Tub Rub cleaning pad and thoroughly rinsed with warm (not cold) water before refilling. Call our order line at 727.573.9611 to order cleaners.

⚠ WARNING: NEVER use paint solvents, acids, acetone, benzene, lacquer thinner, toluene, xylene, or similar chemicals to clean your swim spa shell.

Water Management

Our chemical water purification system is a perfect match for your swim spa.

Depending on usage, the water in your swim spa should be changed every 6-12 months. Upon each change of water it is a good practice to wipe down the swim spa.

If your water quality seems improper, increasing the time the swim spa filters the water (see page 32) may clear up your problem.

Below are some answers to common water chemistry questions.

pH	It is common to have pH fluctuations after adding chemicals to your swim spa or after a party. Let your jets run and give your water time to stabilize. 9 times out of 10, your pH will come back into the 7.2-7.8 range on its own.
MILDEW on cover	Mildew usually grows in the folds and seams of your cover and then drips into your swim spa water causing cloudiness and/or odor. Clean with our special Citra Bright Spray Cleaner and then rinse the inside of your cover with clean warm water.
Foamy water	Foam typically results from soap residue on your skin and hair, or laundry detergent residue on clothing. Take a soapless shower and rinse all clothing in warm water prior to bathing.
CLEAR green or brown water	Your "source water" most likely has dissolved heavy metals. When this is the case, order our special Metal Gon metal remover. Using a pre-filter can remove these contaminants before they get into your swim spa (see page 25).
CLOUDY green water	Algae can be resolved by adding a respected brand of algaecide.
CLOUDY white water	Although a normal condition immediately after filling that dissipates after time, with stabilized water this is a visual indication that the total alkalinity or pH or both are at improper levels. Test your water weekly and maintain proper water chemistry (see page 30).
ODOR and/or CLOUDY water	If your water develops an odor and/or cloudiness, clean your cover and filters and try increasing the amount of time the swim spa filters per day by turning your filtration cycle time or duration up.
HEAVY use	After a period of heavy use, your swim spa may cloud. Shock your swim spa with 2 ounces of non chlorine shock and wait 36 hours.

Specifications

Aquatic 14/X14 (1208/1208D)

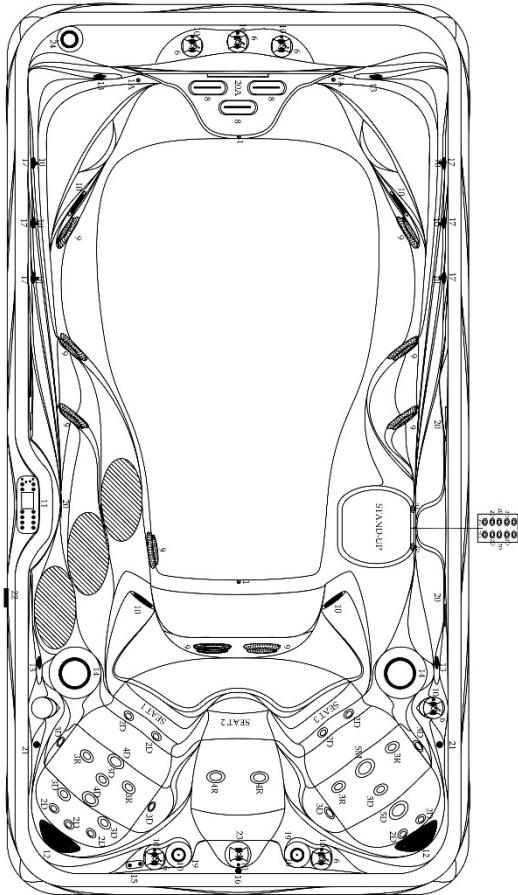

Spa Spec	
Spa Model	1208D/AQ X14, 1208/AQ 14
Spa Dimension	89"x172"x51"
Number Of Seats	4
Water Jets	39
Air Jets	0
Water Capacity (USG/L)	1500/5678
Dry Weight (LBS/KG)	2300/1043
Filled Weight (LBS/KG)	14818/6721
Electrical Rating (VAC/AMP/HZ)	240/48/60
GFCI (AMP)	60

Call-Outs				
Label	Part#	Description	Qty.	Notes
1	73199W	Nozzle wall fitting (Gr)	2	
1A	7818	Wall fitting (Gr)	2	
2D	240-1509DSG-8S, 218-5150,228-1558G	Luxe Glo Cluster storm jet, Directional, Compensator ring, Jet Body	21	
2R	240-1519DSG-8S, 218-5150,228-1558G	Luxe Glo Cluster storm jet, Pulsator, Compensator ring, Jet Body	0	
3D	240-2309DSG-8S, 718-6960,228-0308G	Luxe Glo Mini storm jet, Directional, Compensator ring, Jet Body	8	
3R	240-2329DSG-8S, 718-6960,228-0308G	Luxe Glo Mini storm jet, Twin roto, Compensator ring, Jet Body	4	
4D	240-8309DSG-8S, 218-4010,228-0408G	Luxe Glo Poly storm jet, Directional, Compensator ring, Jet Body	2	
4R	240-8319DSG-8S, 218-4010,228-0408G	Luxe Glo Poly storm jet, Rotational, Compensator ring, Jet Body	2	
5D	240-6109DSG-8S, 218-6680,228-0048G	Luxe Glo Power storm jet, Directional Compensator ring, Jet Body	1	
5M	240-6139DSG-8S, 218-6680,228-0048G	Luxe Glo Power storm jet, MassageCompensator ring, Jet Body	1	
6	25059-101-000, 25090-089-200	1"AIR Control Halo, GP/Sil/GP with LED bezel	6	
7	25056-111-000, 25030-089-200	1 "on-off valve Halo, GP/Sil/GP with LED bezel	0	
8	210-5109-DSGS	River Jet Assembly	3	
9	640-3790SGA V	251GPM Super Hi-Flo 2.5" Suction (metal)	9	
10	1219S, 1310A, 1312A, 1318A, 1315, 1317, 1338	Light Kit 5", LED contr-r, 6-LED spyder, 2-LED spyder, 9-LED light, Cables Assy	4+1+3+1+ 4+1+1	
11	52797-03, 12644	Topside panel ML900, overlay	1+1	
12	823690	Pillow tri-curve	2	
13	1144	Speaker oval, 2.5" PP (Graphite)	4	OPTION
14	1298	Elite skim Filter Assy.(Gr)	2	
15	52747, 12703	Aux. panel AX20, overlay	1+1	
16	7017, 7018	Tether, 3 holes plate	1+1	OPTION
17	210-9309S-DSG	Standard Water Feature	6	
18	3126, 3129, 3130	FRST lens, nuts, o-rings	0	
19	630-0038	Cup Holder LED	2	
20	5456	9" Hand rail ss	3	
20A	5457	12" Hand rail ss	1	
21	1307	Row machine w. hardware	1	OPTION
22	1266, 1267, 1268	Drain-valve Assy. with adapters	1	
23	25058-101-000, 25048-089-200	2 "Diverter valve Halo, GP/Sil/GP with LED bezel	1	
24	600-4609DSG	1.5" ON-OFF Valve	1	
N/A	7136, 6023, 310-0140	2 Speed Motor; 8' Cord ; Wet end 0140;	1	
N/A	7135, 300050168, 310-0140	1 Speed Motor; 14' Cord ; Wet end 0140;	3	
N/A	6167, 6024, 310-0800	Circ. pump motor; 8' Cord ; Wet end 0800;	1	
N/A	56261-01	Balboa Pack PEL2SWIM	1	
N/A	480044	Splitter 2-speed pump to ozone-pump	1	
N/A	5071, 7399	Ozonator w/ Cord, Injector	2+2	
N/A	7068	Swim Spas Owner's Manual	1	
N/A	SS21A	Spa Cover	1	
N/A	1143, 1145, 1146, 1142, 1147	MRD85i Audio system, Subwoofer -4, harness WH-205, power supply 100-240vac, remote control	1	OPTION

Aquatic 14/X14 (1208-EX/1208D-EX) Export

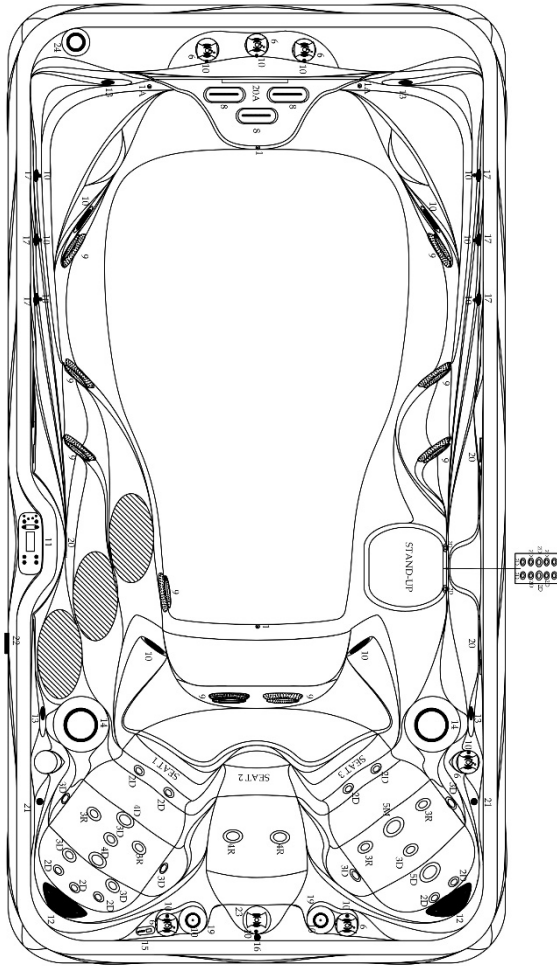

Spa Spec	
Spa Model	1208D-EX/AQ X14-EX, 1208-EX/AQ 14-EX
Spa Dimension	89"x172"x51"
Number Of Seats	4
Water Jets	39
Air Jets	0
Water Capacity (USG/L)	1500/5678
Dry Weight (LBS/KG)	2300/1043
Filled Weight (LBS/KG)	14818/6721
Electrical Rating (VAC/AMP/HZ)	220-240/3x16/50
RCD (AMP)	IEE REQ.

Call-Outs				
Label	Part#	Description	Qty.	Notes
1	73199W	Nozzle wall fitting (Gr)	2	
1A	7818	Wall fitting (Gr)	2	
2D	240-1509DSG-8S, 218-5150,228-1558G	Luxe Glo Cluster storm jet, Directional, Compensator ring, Jet Body	21	
2R	240-1519DSG-8S, 218-5150,228-1558G	Luxe Glo Cluster storm jet, Pulsator, Compensator ring, Jet Body	0	
3D	240-2309DSG-8S, 718-6960,228-0308G	Luxe Glo Mini storm jet, Directional, Compensator ring, Jet Body	8	
3R	240-2329DSG-8S, 718-6960,228-0308G	Luxe Glo Mini storm jet, Twin roto, Compensator ring, Jet Body	4	
4D	240-8309DSG-8S, 218-4010,228-0408G	Luxe Glo Poly storm jet, Directional, Compensator ring, Jet Body	2	
4R	240-8319DSG-8S, 218-4010,228-0408G	Luxe Glo Poly storm jet, Rotational, Compensator ring, Jet Body	2	
5D	240-6109DSG-8S, 218-6680,228-0048G	Luxe Glo Power storm jet, Directional Compensator ring, Jet Body	1	
5M	240-6139DSG-8S, 218-6680,228-0048G	Luxe Glo Power storm jet, MassageCompensator ring, Jet Body	1	
6	25059-101-000, 25090-089-200	1"Air Control Halo, GP/Sil/GP with LED bezel	6	
7	25056-111-000, 25030-089-200	1 "on-off valve Halo, GP/Sil/GP with LED bezel	0	
8	210-5109-DSGS	River Jet Assembly	3	
9	640-3790SGAV	251GPM Super Hi-Flo 2.5" Suction (metal)	9	
10	1219S, 1310A, 1312A, 1318A, 1315, 1317, 1338,	Light Kit 5", LED contr-r, 6-LED spyder, 2-LED spyder, 9-LED light, Cables Assy	4+1+3+1+ 4+1+1	
11	52797-03, 12644	Topside panel ML900 w. overlay	1	
12	823690	Pillow tri-curve	2	
13	1144	Speaker oval, 2.5" PP (Graphite)	4	option
14	1298	Elite skim Filter Assy.(Gr)	2	
15	52747, 12703	Panel AX20 w. overlay	1+1	
16	7017, 7018	Tether, 3 holes plate	1+1	option
17	210-9309S-DSG	Standard Water Feature	6	
18	3126, 3129, 3130	1" FRST lens, nuts, o-rings	0	
19	630-0038	Cup Holder LED	2	
20	5456	9" Hand rail ss	3	
20A	5457	12" Hand rail ss	1	
21	1307	Row machine w. hardware	1	option
22	1266, 1267, 1268	Drain-valve Assy. with adapters	1	
23	25058-101-000, 25048-089-200	2 "Diverter valve Halo, GP/Sil/GP with LED bezel	1	
24	600-4609DSG	1.5" ON-OFF Valve	1	
N/A	7789, 6022, 310-0180	2 Speed Motor; 8' Cord ; Wet end 0180;	1	Spa side,
N/A	7788, 300050168, 310-0180	1 Speed Motor; 14' Cord ; Wet end 0180;	3	Swim side
N/A	7794, 6024, 310-0800	Circ. pump motor; 8' Cord ; Wet end 0800;	1	
N/A	56502	Balboa Pack PGL2P3P4	1	Setting 1
N/A	54509-01	Balboa Pack GS500Z	0	
N/A	480044	Splitter 2-speed pump to ozone-pump	1	
N/A	5071, 7399	Ozonator w/ Cord, Injector	2+2	
N/A	7068	Swim Spas Owner's Manual	1	
N/A	SS21A	Spa Cover	1	
N/A	1143, 1145, 1146, 1142, 1147	MRD85i Audio system, Subwoofer -4, harness WH-205, power supply 100-240vac, remote control	1	option

Aquatic 12/X12 (1209/1209D)

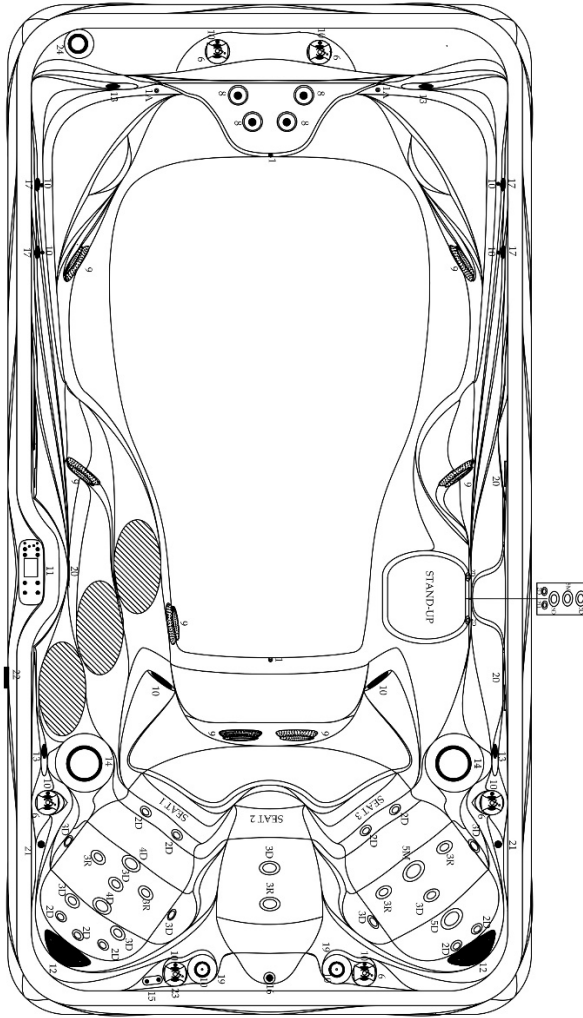

Spa Spec

Spa Model	1209D/AQ X12, 1209/AQ 12
Spa Dimension	89"x148"x51"
Number Of Seats	4
Water Jets	34
Air Jets	0
Water Capacity (USG/L)	1300/4920
Dry Weight (LBS/KG)	2100/953
Filled Weight (LBS/KG)	12947/5873
Electrical Rating (VAC/AMP/HZ)	240/48/60
GFCI (AMP)	60

Call-Outs				
Label	Part#	Description	Qty.	Notes
1	73199W	Nozzle wall fitting (Gr)	2	
1A	7818	Wall fitting (Gr)	2	
2D	240-1509DSG-8S, 218-5150,228-1558G	Luxe Glo Cluster storm jet, Directional, Compensator ring, Jet Body	13	
2R	240-1519DSG-8S, 218-5150,228-1558G	Luxe Glo Cluster storm jet, Pulsator, Compensator ring, Jet Body	0	
3D	240-2309DSG-8S, 718-6960,228-0308G	Luxe Glo Mini storm jet, Directional, Compensator ring, Jet Body	9	
3R	240-2329DSG-8S, 718-6960,228-0308G	Luxe Glo Mini storm jet, Twin roto, Compensator ring, Jet Body	5	
4D	240-8309DSG-8S, 218-4010,228-0408G	Luxe Glo Poly storm jet, Directional, Compensator ring, Jet Body	2	
4R	240-8319DSG-8S, 218-4010,228-0408G	Luxe Glo Poly storm jet, Rotational, Compensator ring, Jet Body	0	
5D	240-6109DSG-8S, 218-6680,228-0048G	Luxe Glo Power storm jet, Directional Compensator ring, Jet Body	3	
5M	240-6139DSG-8S, 218-6680,228-0048G	Luxe Glo Power storm jet, MassageCompensator ring, Jet Body	2	
6	25059-101-000,	1"Air Control Halo, GP/Sil/GP with LED bezel	5	
7	25056-111-000,	1 "on-off valve Halo, GP/Sil/GP with LED bezel	0	
8	210-7269-DSGS	Swim Spas Jets Assy.	4	
9	640-3790SGA V	251GPM Super Hi-Flow 2.5" Suction (metal)	7	
10	1219S, 1310A, 1312A, 1318A, 1315, 1317, 1338	Light Kit 5", LED contr-r, 6-LED spyder, 2-LED spyder, 9-LED light, Cables Assy	2+1+2+1+ 2+1	
11	52798, 12701	Topside panel ML700, overlay	1	
12	823690	Pillow tri-curve	2	
13	1144	Speaker oval, 2.5" PP (Graphite)	4	OPTION
14	1298	Elite skim Filter Assy.(Gr)	2	
15	52747, 12703	Aux panel AX20, overlay	1+1	
16	7017, 7018	Tether, 3 holes plate	1+1	OPTION
17	210-9309S-DSG	Standard Water Feature	4	
18	3126, 3129, 3130	FRST lens, nuts, o-rings	0	
19	630-0038	Cup Holder LED	2	
20	5456	9" Hand rail ss	3	
21	1307	Row machine w. hardware	1	OPTION
22	1266, 1267, 1268	Drain-valve Assy. with adapters	1	
23	25058-101-000, 25048-089-200	2" Diverter valve, Halo, GP/SIL/GP	1	
24	600-4609DSG	1.5" ON-OFF Valve	1	
N/A	7136, 6023, 310-0140	2 Speed Motor; 8' Cord ; Wet end 0140;	1	Spa side
N/A	7135, 300050168, 310-0140	1 Speed Motor; 14' Cord ; Wet end 0140;	2	Swim side
N/A	6167, 6024, 310-0800	Circ. pump motor; 8' Cord ; Wet end 0800;	1	
N/A	56261-01	Balboa Pack PEL2SWIM	1	
N/A	480044	Splitter 2-speed pump to ozone-pump	1	
N/A	5071, 7399	Ozonator w/ Cord, Injector	2+2	
N/A	7068, 7068A	Swim Spas Owner's Manual	1	
N/A	SS22A	Spa Cover	1	
N/A	1143, 1145, 1146, 1142, 1147	MRD85i Audio system, Subwoofer -4, harness WH-205, power supply 100-240vac, remote control	1	OPTION

Aquatic 12/X12 (1209-EX/1209D-EX) Export

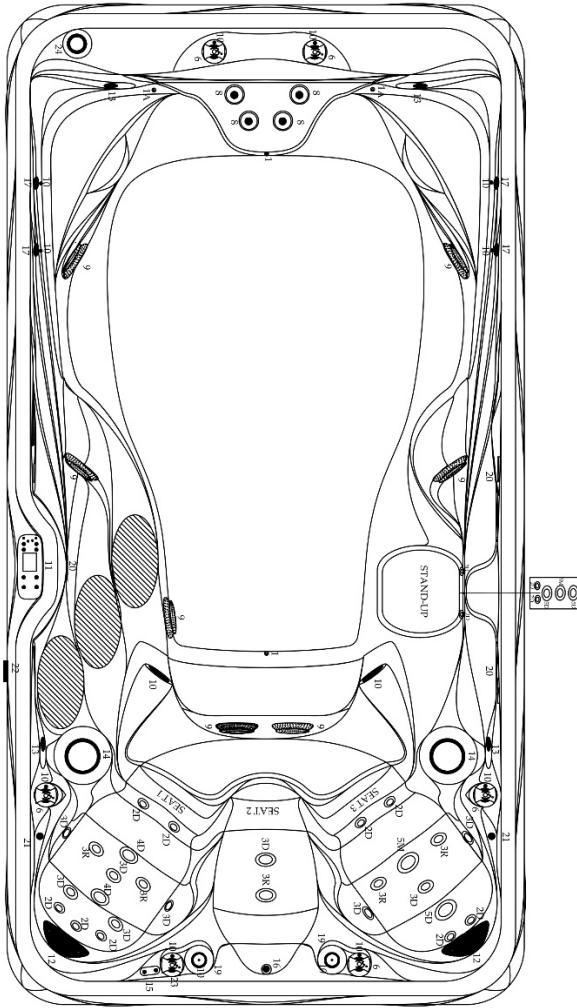

Spa Spec	
Spa Model	1209D-EX/1209-EX/Aquatic12-EX
Spa Dimension	89"x148"x51"
Number Of Seats	4
Water Jets	34
Air Jets	0
Water Capacity (USG/L)	1300/4920
Dry Weight (LBS/KG)	2100/953
Filled Weight (LBS/KG)	12947/5873
Electrical Rating (VAC/AMP/HZ)	220-240/3x16/50
RCD (AMP)	IEE REQ.

Call-Outs				
Label	Part#	Description	Qty.	Notes
1	73199W	Nozzle wall fitting (Gr)	2	
1A	7818	Wall fitting (Gr)	2	
2D	240-1509DSG-8S, 218-5150,228-1558G	Luxe Glo Cluster storm jet, Directional, Compensator ring, Jet Body	13	
2R	240-1519DSG-8S, 218-5150,228-1558G	Luxe Glo Cluster storm jet, Pulsator, Compensator ring, Jet Body	0	
3D	240-2309DSG-8S, 718-6960,228-0308G	Luxe Glo Mini storm jet, Directional, Compensator ring, Jet Body	9	
3R	240-2329DSG-8S, 718-6960,228-0308G	Luxe Glo Mini storm jet, Twin roto, Compensator ring, Jet Body	5	
4D	240-8309DSG-8S, 218-4010,228-0408G	Luxe Glo Poly storm jet, Directional, Compensator ring, Jet Body	2	
4R	240-8319DSG-8S, 218-4010,228-0408G	Luxe Glo Poly storm jet, Rotational, Compensator ring, Jet Body	0	
5D	240-6109DSG-8S, 218-6680,228-0048G	Luxe Glo Power storm jet, Directional Compensator ring, Jet Body	3	
5M	240-6139DSG-8S, 218-6680,228-0048G	Luxe Glo Power storm jet, MassageCompensator ring, Jet Body	2	
6	25059-101-000,	1" AIR Control Halo, GP/Sil/GP with LED bezel	5	
7	25056-111-000,	1 "on-off valve Halo, GP/Sil/GP with LED bezel	0	
8	210-7269-DSGS	Swim Spas Jets Assy.	4	
9	640-3790SGA V	251GPM Super Hi-Flo 2.5" Suction (metal)	7	
10	1219S, 1310A, 1312A, 1318A, 1315, 1317, 1338	Light Kit 5", LED contr-r, 6-LED spyder, 2-LED spyder, 9-LED light, Cables Assy	2+1+2+2+ 1+2+1	
11	52798, 12701	Topside panel ML700, overlay	1	
12	823690	Pillow tri-curve	2	
13	1144	Speaker oval, 2.5" PP (Graphite)	4	OPTION
14	1298	Elite skim Filter Assy.(Gr)	2	
15	52747, 12703	Panel AX20 w. overlay	1+1	
16	7017, 7018	Tether, 3 holes plate	1+1	OPTION
17	210-9309S-DSG	Standard Water Feature	4	
18	3126, 3129, 3130	FRST lens, nuts, o-rings	0	
19	630-0038	Cup Holder LED	2	
20	5456	9" Hand rail ss	3	
21	1307	Row machine w. hardware	1	OPTION
22	1266, 1267, 1268	Drain-valve Assy. with adapters	1	
23	25058-101-000, 25048-089-200	2" Diverter valve, Halo, GP/SIL/GP	1	
24	600-4609DSG	1.5" ON-OFF Valve	1	
N/A	7789, 6023, 310-0180	2 Speed Motor; 8' Cord ; Wet end 0140;	1	Spa side
N/A	7788, 300050168, 310-0180	1 Speed Motor; 14' Cord ; Wet end 0140;	2	Swim side
N/A	7794, 6024, 310-0800	Circ. pump motor, 8' Cord ; Wet end 0800;	1	
N/A	56502	Balboa Pack PGL2P3P4	1	Setup 3
N/A	54509-01	GS500Z Pack	0	
N/A	480044	Splitter 2-speed pump to ozone-pump	1	
N/A	5071, 7399	Ozonator w/ Cord, Injector	2+2	
N/A	7068, 7068A	Swim Spas Owner's Manual	1	
N/A	SS22A	Spa Cover	1	
N/A	1143, 1145, 1146, 1142, 1147	MRD85i Audio system, Subwoofer -4, harness WH-205, power supply 100-240vac, remote control	1	OPTION

Aquatic X10 (1210D)

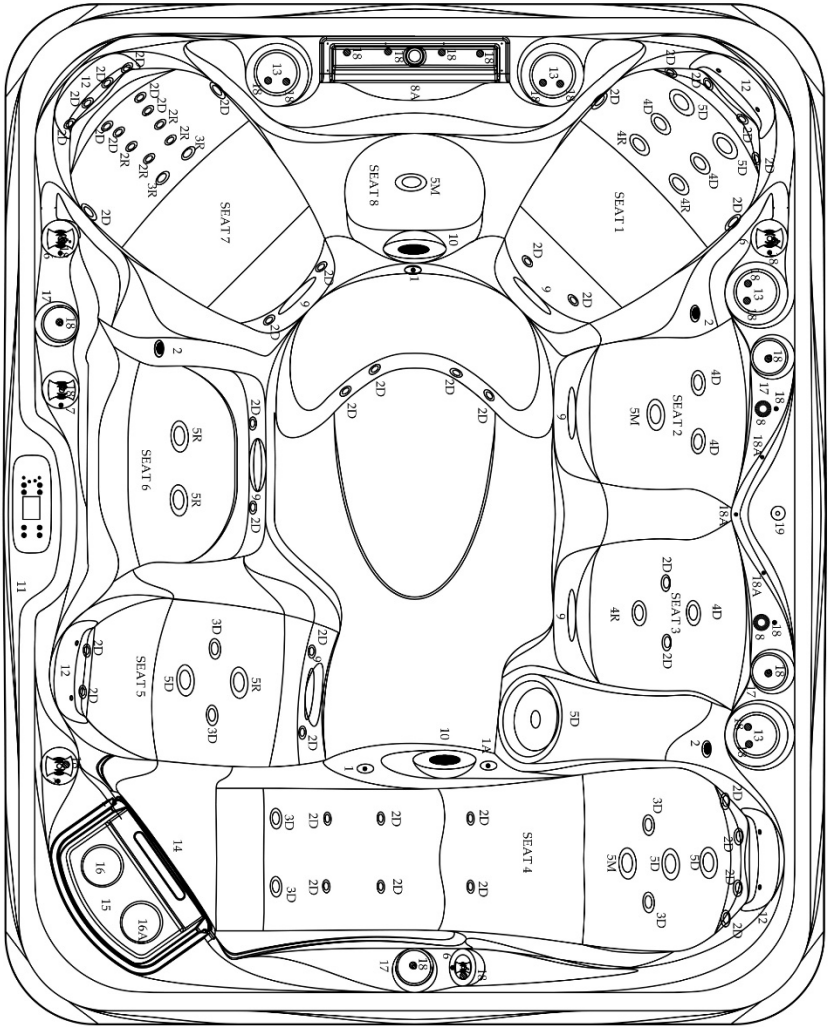

Spa Spec	
Spa Model	1210D/AQ X10
Spa Dimension	91"x 114"x 38"
Number Of Seats	8
Water Jets	77
Water Capacity (USG/L)	575/2177
Dry Weight (LBS/KG)	1146/520
Filled Weight (LBS/KG)	5946/2697
Electrical Rating (VAC/AMP/HZ)	240/48/60
GFCI (AMP)	60

Call-Outs				
Label	Part#	Description	Qty.	Notes
1	73199W	Nozzle wall fitting (Gr)	2	
1A	7818	Wall fitting (Gr)	1	
2	240-1509DSG-8S, 218-5150, 228-1558G	Luxe Glo Cluster storm jet, Directional, No adj. Compensator ring, Jet Body	3	
2D	240-1509DSG-8S, 218-5150, 228-1558G	Luxe Glo Cluster storm jet, Directional, Compensator ring, Jet Body	42	
2R	240-1519DSG-8S, 218-5150, 228-1558G	Luxe Glo Cluster storm jet, Pulsator, Compensator ring, Jet Body	4	
3D	240-2309DSG-8S, 718-6960, 228-0308G	Luxe Glo Mini storm jet, Directional, Compensator ring, Jet Body	6	
3R	240-2329DSG-8S, 718-6960, 228-0308G	Luxe Glo Mini storm jet, Twin roto, Compensator ring, Jet Body	2	
4D	240-8309DSG-8S, 218-4010, 228-0408G	Luxe Glo Poly storm jet, Directional, Compensator ring, Jet Body	5	
4R	240-8319DSG-8S, 218-4010, 228-0408G	Luxe Glo Poly storm jet, Rotational, Compensator ring, Jet Body	3	
5D	240-6109DSG-8S, 218-6680, 228-0048G	Luxe Glo Power storm jet, Directional Compensator ring, Jet Body	6	
5R	240-6129DSG-8S, 218-6680, 228-0048G	Luxe Glo Power storm jet, Dual swirlCompensator ring, Jet Body	3	
5M	240-6139DSG-8S, 218-6680, 228-0048G	Luxe Glo Power storm jet, MassageCompensator ring, Jet Body	3	
5MM	240-6149DSG-8S, 218-6680, 228-0048G	Luxe Glo Power storm jet, Multi-Massage, Compensator ring, Jet Body	0	
6	25059-101-000,	1"Air Control Halo, GP/Sil/GP with LED bezel	3	
7	25056-111-000,	1"on-off valve Halo, GP/Sil/GP with LED bezel	2	
8	210-9209DSG	Standard water feature	2	
8A	675-5308L	18" LED Spillway waterfall with valve	1	
9	640-3790SGAV	251GPM Super Hi-Flo 2.5" Suction (metal)	6	
10	1219S	Light Kit 5", ,SS	2	
11	52798, 12701	Topside panel ML700, overlay	1+1	
12	3133	Small rounded Pillow	4	
13	675-2010L	Speaker Magna Tune pop-up rot. LED(Graphite)	4	Optional
14	822817	Weir door(Gr/Silver)	1	
15	1238	Filter Lid(Gr)	1	
16, 16A	822070, 61368	Cartridge Filter	1+1	1-1/2"NPT, 2"NPT
17	630-0038	Cup Holder LED	4	
18	1310A, 1312A, 1318A, 1315, 1317, 1338	LED contr-r, 6-LED spyder, 2-LED spyder, 9-LED light, Cables Assy	1+4+1+2+ 1+1+24	
18A	400372-N	Small lens with gasket, nut	3	
19	670-2009-DSG, 219-5910	Water nozzle wall fitting, graphite w. retainer	1+1	
N/A	7136, 6023, 310-0140	2 Speed Motor; 8' Cord ; Wet end 0140;	3	
N/A	7135, 6024, 310-0140	1 Speed Motor; 8' Cord ; Wet end 0140;	0	
N/A	6167, 6024, 310-0800	Circ. pump motor; 8' Cord ; Wet end 0800;	1	
N/A	56424	Balboa Pack PEL2P3S2	1	
N/A	5071, 7399	Ozonator w/ Cord, Injector	2+2	
N/A	7068, 7068A	Swim Spa Owner's Manual	1	
N/A	XXXX	Spa Cover	1	
N/A	MRD80i, RM-14, 1145, 1146, 1142	MRD80i; Housing, Subwoofer, harness WH-205, power supply 100-240vac	1	Optional

Aquatic X10 (1210D-EX) Export

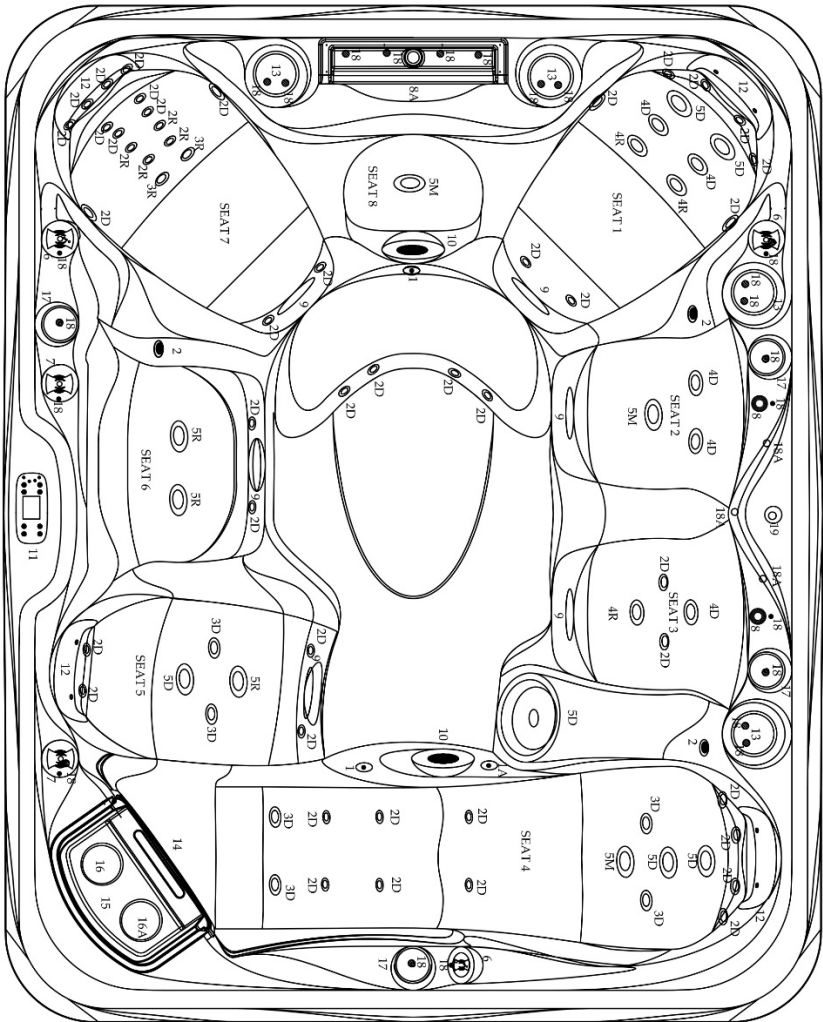

Spa Spec	
Spa Model	1210D-EX/AQ X10-EX
Spa Dimension	91"x 114"x 38"
Number Of Seats	8
Water Jets	77
Water Capacity (USG/L)	575/2177
Dry Weight (LBS/KG)	1146/520
Filled Weight (LBS/KG)	5946/2697
Electrical Rating (VAC/AMP/HZ)	220-240/3x16/50
RCD(AMP)	IEE REQ.

Call-Outs				
Label	Part#	Description	Qty.	Notes
1	73199W	Nozzle wall fitting (Gr)	2	
1A	7818	Wall fitting (Gr)	1	
2	240-1509DSG-8S, 218-5150, 228-1558G	Luxe Glo Cluster storm jet, Directional, No adj. Compensator ring, Jet Body	3	
2D	240-1509DSG-8S, 218-5150, 228-1558G	Luxe Glo Cluster storm jet, Directional, Compensator ring, Jet Body	42	
2R	240-1519DSG-8S, 218-5150, 228-1558G	Luxe Glo Cluster storm jet, Pulsator, Compensator ring, Jet Body	4	
3D	240-2309DSG-8S, 718-6960, 228-0308G	Luxe Glo Mini storm jet, Directional, Compensator ring, Jet Body	6	
3R	240-2329DSG-8S, 718-6960, 228-0308G	Luxe Glo Mini storm jet, Twin roto, Compensator ring, Jet Body	2	
4D	240-8309DSG-8S, 218-4010, 228-0408G	Luxe Glo Poly storm jet, Directional, Compensator ring, Jet Body	5	
4R	240-8319DSG-8S, 218-4010, 228-0408G	Luxe Glo Poly storm jet, Rotational, Compensator ring, Jet Body	3	
5D	240-6109DSG-8S, 218-6680, 228-0048G	Luxe Glo Power storm jet, Directional Compensator ring, Jet Body	6	
5R	240-6129DSG-8S, 218-6680, 228-0048G	Luxe Glo Power storm jet, Dual swirlCompensator ring, Jet Body	3	
5M	240-6139DSG-8S, 218-6680, 228-0048G	Luxe Glo Power storm jet, MassageCompensator ring, Jet Body	3	
5MM	240-6149DSG-8S, 218-6680, 228-0048G	Luxe Glo Power storm jet, Multi-Massage, Compensator ring, Jet Body	0	
6	25059-101-000,	1" AIR Control Halo, GP/Sil/GP with LED bezel	3	
7	25056-111-000,	1" on-off valve Halo, GP/Sil/GP with LED bezel	2	
8	210-9209DSG	Standard water feature	2	
8A	675-5308L	18" LED Spillway waterfall with valve	1	
9	640-3790SGA V	251GPM Super Hi-Flo 2.5" Suction (metal)	6	
10	1219S	Light Kit 5", SS	2	
11	52798, 12701	Topside panel ML700, overlay	1+1	
12	3133	Small rounded Pillow	4	
13	675-2010L	Speaker Magna Tune pop-up rot. LED(Graphite)	4	Optional
14	822817	Weir door(Gr/Silver)	1	
15	1238	Filter Lid(Gr)	1	
16, 16A	822070, 61368	Cartridge Filter	1+1	1-1/2"NPT, 2"NPT
17	630-0038	Cup Holder LED	4	
18	1310A, 1312A, 1318A, 1315, 1317, 1338	LED contr-r, 6-LED spyder, 2-LED spyder, 9-LED light, Cables Assy	1+4+1+2+ 1+1+24	
18A	400372-N	Small lens with gasket, nut	3	
19	670-2009-DSG, 219-5910	Water nozzle wall fitting, graphite w. retainer	1+1	
N/A	7789, 6023, 310-0180	2 Speed Motor; 8' Cord ; Wet end 0180;	3	P1, P2, P3
N/A	7788, 6024, 310-0180	1 Speed Motor; 8' Cord ; Wet end 0180;	0	
N/A	7794, 6024, 310-0800	Circ. pump motor; 8' Cord ; Wet end 0800;	1	CP
N/A	56502	Balboa Pack PGL2P3P4	1	Setup 2
N/A	5071, 7399	Ozonator w/ Cord, Injector	1+1	
N/A	7068, 7068A	Swim Spa Owner's Manual	1	
N/A	XXXX	Spa Cover	1	
N/A	MRD80i, RM-14, 1145, 1146, 1142	MRD80i, Housing, Subwoofer, harness WH-205, power supply 100-240vac	1	Optional

Aquatic 16/X16 (1211/1211D)

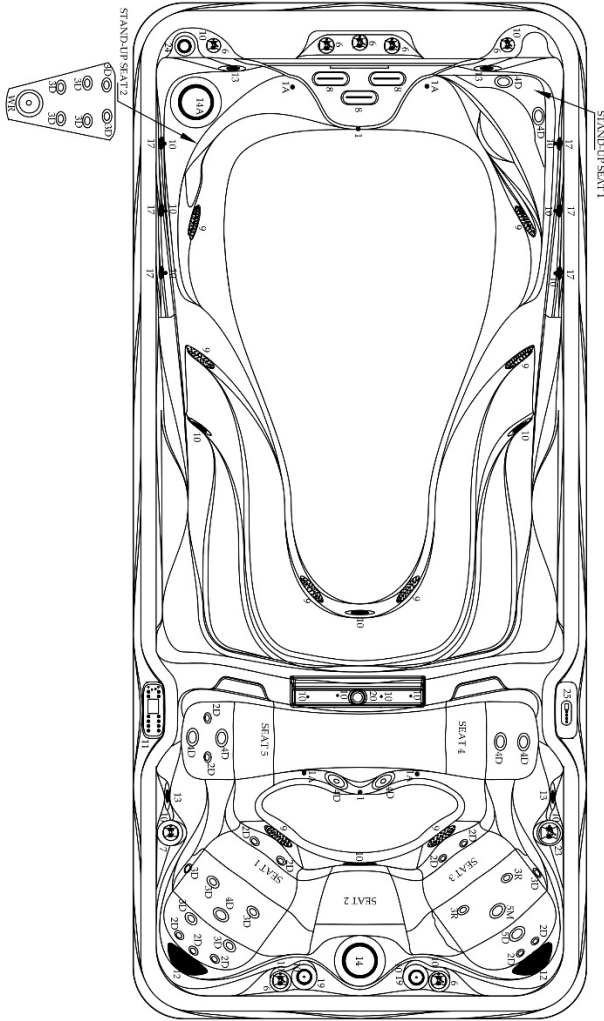

Spa Spec	
Spa Model	1211D/AQ X16, 1211/AQ 16
Spa Dimension	89"x198"x51"
Number Of Seats	7
Water Therapy Jets	37
Swim Jets	3
Water Capacity (US/G/L)	1710/6473
Dry Weight (LBS/KG)	2480/1124
Filled Weight (LBS/KG)	16750/7597
Electrical Rating, GFCI (VAC/AMP/HZ/AMP)	Service 1: 240/48/60/60
Electrical Rating, GFCI (VAC/AMP/HZ/AMP)	Service 2: 240/32/60/40

Call-Outs				
Label	Part#	Description	Qty.	Notes
1	73199W	Nozzle wall fitting (Gr)	2	
1A	7818	Wall fitting (Gr)	4	
2D	240-1509DSG-8S, 218-5150,228-1558G	Luxe Glo Cluster storm jet, Directional, Compensator ring, Jet Body	11	
2R	240-1519DSG-8S, 218-5150,228-1558G	Luxe Glo Cluster storm jet, Pulsator, Compensator ring, Jet Body	0	
3D	240-2309DSG-8S, 718-6960,228-0308G	Luxe Glo Mini storm jet, Directional, Compensator ring, Jet Body	12	
3R	240-2329DSG-8S, 718-6960,228-0308G	Luxe Glo Mini storm jet, Twin roto, Compensator ring, Jet Body	2	
4D	240-8309DSG-8S, 218-4010,228-0408G	Luxe Glo Poly storm jet, Directional, Compensator ring, Jet Body	9	
4R	240-8319DSG-8S, 218-4010,228-0408G	Luxe Glo Poly storm jet, Rotational, Compensator ring, Jet Body	0	
5D	240-6109DSG-8S, 218-6680,228-0048G	Luxe Glo Power storm jet, Directional Compensator ring, Jet Body	1	
5M	240-6139DSG-8S, 218-6680,228-0048G	Luxe Glo Power storm jet, MassageCompensator ring, Jet Body	1	
WR	239-0029S-DSG, 228-2000G	Thread-In Whirlpool Jet, Thread -in body w.grommet gasket	1	WR-adj.(3/4")
6	25059-101-000, 25090-089-200	1"Air Control Halo, GP/Sil/JP with LED bezel	7	
7	25056-111-000, 25030-089-200	1 "on-off valve Halo, GP/Sil/JP with LED bezel	1	
8	210-5109-DSGS	River Jet Assembly	3	
9	640-3790SGA V	251GPM Super Hi-Flo 2.5" Suction (metal)	8	
10	1219S, 1310A, 1312A, 1318A, 1315, 1317, 1338	Light Kit 5", LED contr-r, 6-LED spyder, 2-LED spyder, 9-LED light, Cables Assy	4+1+4+1+1 4+1+1	
11	52797-03, 12644	Topside panel ML907, overlay	1+1	
12	823690	Pillow tri-curve	2	
13	1144	Speaker oval, 2.5" PP (Graphite)	4	OPTION
14	1298	50 Sq.Ft Elite skim Filter Assy.(Gr)	1	
14A	25359-097-000	100Sq.Ft Elite skim filter Assy.(Gr)	1	
15	52747, 12703	Aux. panel AX20, overlay	0	
16	7017, 7018	Tether, 3 holes plate	0	OPTION
17	210-9309S-DSG	Standard Water Feature	6	
18	3126, 3129, 3130	FRST lens, nuts, o-rings	0	
19	630-0038	Cup Holder LED	3	
20	765-5308L	18" LED Spillway waterfall w. valve	1	
20A	5457	12" Hand rail ss	1	
21	1307	Row machine w. hardware	0	OPTION
22	1266, 1267, 1268	Drain-valve Assy. with adapters	1	
23	25058-101-000, 25048-089-200	2 "Diverter valve Halo, GP/Sil/JP with LED bezel	1	
24	600-4609DSG	1.5" ON-OFF Valve	1	
25	53999	Top side panel MMP 260	1	
N/A	7136, 6023, 310-0140	2 Speed Motor; 8' Cord ; Wet end 0140;	1	
N/A	3420620-10, 6023	2 Speed Pump (Motor BN34,Wet end 1140SD); 8' cord	1	
N/A	7135, 300050168, 310-0140	1 Speed Motor; 14' Cord ; Wet end 0140;	3	
N/A	6167, 6024, 310-0800	Circ. pump motor; 8' Cord ; Wet end 0800;	2	
N/A	56261-01	Balboa Pack PEL2SWIM	1	
N/A	55940	Balboa Pack VS500Z	1	
N/A	5071, 7399	Ozonator w/ Cord, Injector	2+2	
N/A	7068	Swim Spas Owner's Manual	1	
N/A	SS21A	Spa Cover	1	
N/A	1143, 1145, 1146, 1142, 1147	MRD85i Audio system, Subwoofer -4, harness WH-205, power supply 100-240vac, remote control	0	OPTION

Aquatic 16/X16 (1211-EX /1211D-EX) Export

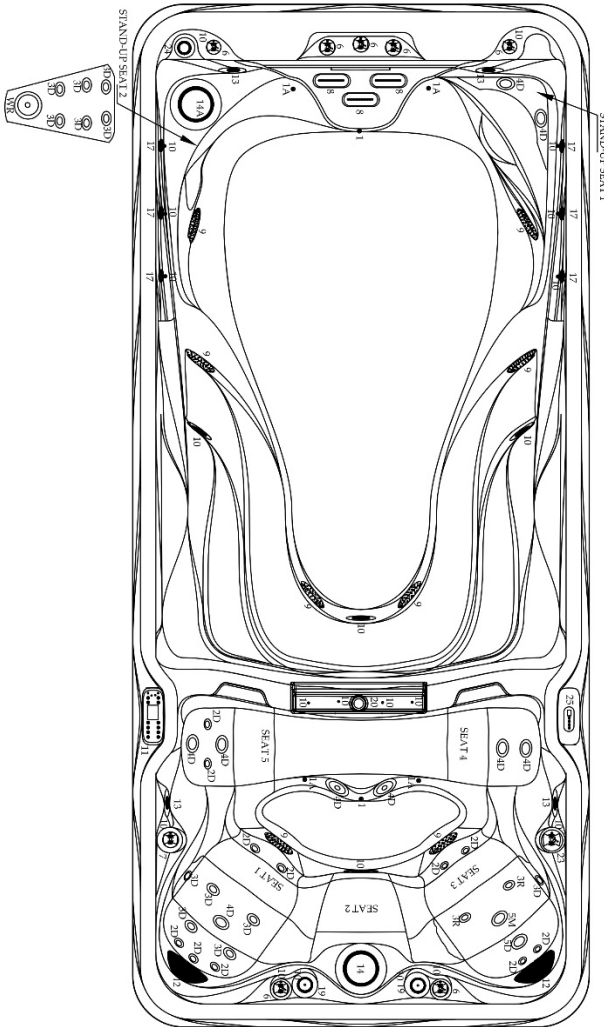

Spa Spec

Spa Model	1211D-EX/AQ X16-EX, 1211-EX/AQ 16-EX
Spa Dimension	89" x 198" x 51"
Number Of Seats	7
Water Therapy Jets	37
Swim Jets	3
Water Capacity (USG/L)	1710/6473
Dry Weight (LBS/KG)	2480/1124
Filled Weight (LBS/KG)	16750/7597
Electrical Rating (VAC/AMP/HZ)	Service 1: 220-240/3x16/50
Electrical Rating (VAC/AMP/HZ)	Service 2: 220-240/1x32/50

Call-Outs				
Label	Part#	Description	Qty.	Notes
1	73199W	Nozzle wall fitting (Gr)	2	
1A	7818	Wall fitting (Gr)	4	
2D	240-1509DSG-8S, 218-5150,228-1558G	Luxe Glo Cluster storm jet, Directional, Compensator ring, Jet Body	11	
2R	240-1519DSG-8S, 218-5150,228-1558G	Luxe Glo Cluster storm jet, Pulsator, Compensator ring, Jet Body	0	
3D	240-2309DSG-8S, 718-6960,228-0308G	Luxe Glo Mini storm jet, Directional, Compensator ring, Jet Body	12	
3R	240-2329DSG-8S, 718-6960,228-0308G	Luxe Glo Mini storm jet, Twin roto, Compensator ring, Jet Body	2	
4D	240-8309DSG-8S, 218-4010,228-0408G	Luxe Glo Poly storm jet, Directional, Compensator ring, Jet Body	9	
4R	240-8319DSG-8S, 218-4010,228-0408G	Luxe Glo Poly storm jet, Rotational, Compensator ring, Jet Body	0	
5D	240-6109DSG-8S, 218-6680,228-0048G	Luxe Glo Power storm jet, Directional Compensator ring, Jet Body	1	
5M	240-6139DSG-8S, 218-6680,228-0048G	Luxe Glo Power storm jet, MassageCompensator ring, Jet Body	1	
WR	239-0029S-DSG, 228-2000G	Thread-In Whirlpool Jet, Thread -in body w.grommet gasket	1	WR-adj.(3/4")
6	25059-101-000, 25090-089-200	1"Air Control Halo, GP/Sil/GP with LED bezel	7	
7	25056-111-000, 25030-089-200	1 "on-off valve Halo, GP/Sil/GP with LED bezel	1	
8	210-5109-DSGS	River Jet Assembly	3	
9	640-3790SGA V	251GPM Super Hi-Flo 2.5" Suction (metal)	8	
10	1219S, 1310A, 1312A, 1318A, 1315, 1317, 1338	Light Kit 5", LED contr-r, 6-LED spyder, 2-LED spyder, 9-LED light, Cables Assy	4+1+4+1+ 4+1+1	
11	52797-03, 12644	Topside panel ML900, overlay	1+1	
12	823690	Pillow tri-curve	2	
13	1144	Speaker oval, 2.5" PP (Graphite)	4	OPTION
14	1298	50 Sq.Ft Elite skim Filter Assy,(Gr)	1	
14A	25359-097-000	100Sq.Ft Elite skim filter Assy,(Gr)	1	
15	52747, 12703	Aux. panel AX20, overlay	0	
16	7017, 7018	Tether, 3 holes plate	0	OPTION
17	210-9309S-DSG	Standard Water Feature	6	
18	3126, 3129, 3130	FRST lens, nuts, o-rings	0	
19	630-0038	Cup Holder LED	3	
20	765-5308L	18" LED Spillway waterfall w. valve	1	
20A	5457	12" Hand rail ss	1	
21	1307	Row machine w. hardware	0	OPTION
22	1266, 1267, 1268	Drain-valve Assy. with adapters	1	
23	25058-101-000, 25048-089-200	2 "Diverter valve Halo, GP/Sil/GP with LED bezel	1	
24	600-4609DSG	1.5" ON-OFF Valve	1	
25	53999	Top side panel MMP 260	1	
N/A	7789, 6023, 310-0180	2 Speed Motor; 8' Cord ; Wet end 0180;	1	
N/A	05320023-8340, 6023	XP2, 50Hz 2 Speed Pump, 1.5HP; 8' cord	1	
N/A	7788, 300050168, 310-0180	1 Speed Motor; 14' Cord ; Wet end 0180;	3	
N/A	7794, 6024, 310-0800	Circ. pump motor; 8' Cord ; Wet end 0800;	2	
N/A	56502	Balboa Pack PGL2P3P4	1	
N/A	54509-01	Balboa Pack GS500Z	1	
N/A	5071, 7399	Ozonator w/ Cord, Injector	2+2	
N/A	7068	Swim Spas Owner's Manual	1	
N/A	SS21A	Spa Cover	1	
N/A	1143, 1145, 1146, 1142, 1147	MRD85i Audio system, Subwoofer -4, harness WH-205, power supply 100-240vac, remote control	0	OPTION

Aquatic 11/X11 (1214/1214D)

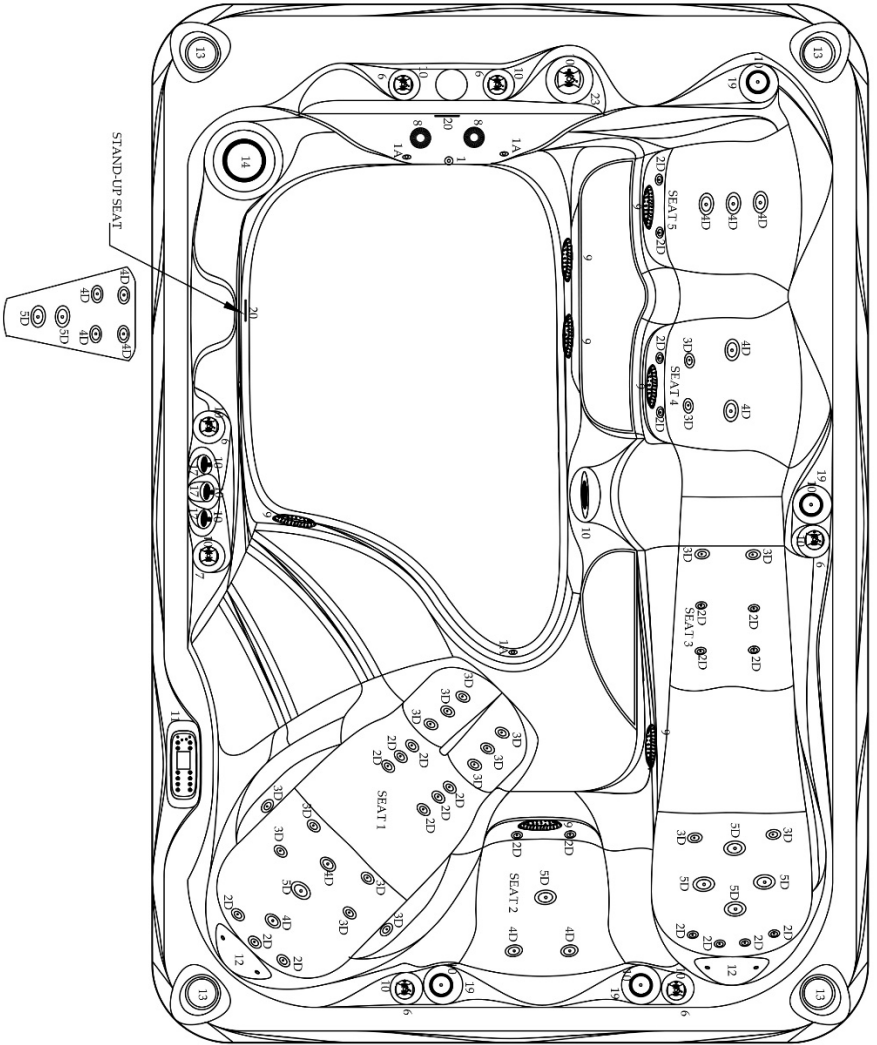

Spa Spec	
Spa Model	1214D/AQ X11,1214/AQ 11
Spa Dimension	89"x132"x51"
Number Of Seats	6
Water Therapy Jets	64
Water Capacity (USG/L)	620/2350
Dry Weight (LBS/KG)	1200/545
Filled Weight (LBS/KG)	6382/2895
Electrical Rating (VAC/AMP/HZ)	240/48/60
GFCI (AMP)	60

Call-Outs				
Label	Part#	Description	Qty.	Notes
1	73199W	Nozzle wall fitting (Gr)	1	
1A	7818	Wall fitting (Gr)	3	
2D	240-1509DSG-8S, 218-5150,228-1558G	Luxe Glo Cluster storm jet, Directional, Compensator ring, Jet Body	23	
2R	240-1519DSG-8S, 218-5150,228-1558G	Luxe Glo Cluster storm jet, Pulsator, Compensator ring, Jet Body	0	
3D	240-2309DSG-8S, 718-6960,228-0308G	Luxe Glo Mini storm jet, Directional, Compensator ring, Jet Body	18	
3R	240-2329DSG-8S, 718-6960,228-0308G	Luxe Glo Mini storm jet, Twin roto, Compensator ring, Jet Body	0	
4D	240-8309DSG-8S, 218-4010,228-0408G	Luxe Glo Poly storm jet, Directional, Compensator ring, Jet Body	13	
4R	240-8319DSG-8S, 218-4010,228-0408G	Luxe Glo Poly storm jet, Rotational, Compensator ring, Jet Body	0	
5D	240-6109DSG-8S, 218-6680,228-0048G	Luxe Glo Power storm jet, Directional Compensator ring, Jet Body	8	
5M	240-6139DSG-8S, 218-6680,228-0048G	Luxe Glo Power storm jet, MassageCompensator ring, Jet Body	0	
6	25059-101-000, 25090-089-200	1" AIR Control Halo, GP/Sil/GP with LED bezel	6	
7	25056-111-000, 25030-089-200	1 "on-off valve Halo, GP/Sil/GP with LED bezel	1	
8	239-0029DSGS, 228-2000G	Thread-in Whirlpool Jet, Thread-in body w. Grommet gasket Assembly	2	
9	640-3790SGA V	251GPM Super Hi-Flo 2.5" Suction (metal)	7	
10	1219S, 1310A, 1312A, 1318A, 1315, 1317, 1338	Light Kit 5", LED contr-r, 6-LED spyder, 2-LED spyder, 9-LED light, Cables Assy	1+1+2+1+ 1+1+1	
11	52798, 12701	Topside panel ML700, overlay	1+1	
12	823690	Pillow tri-curve	2	
13	1144	Speaker 2.5" (Graphite)	4	OPTION
14	25359-097-000	100Sq.Ft Elite skim filter Assy.(Gr)	1	
15	52747, 12703	Aux. panel AX20, overlay	0	
16	7017, 7018	Tether, 3 holes plate	0	OPTION
17	210-9309S-DSG	Standard Water Feature	3	
18	3126, 3129, 3130	FRST lens, nuts, o-rings	0	
19	630-0038	Cup Holder LED	4	
20	5456	9" Hand rail ss	2	
21	1307	Row machine w. hardware	0	OPTION
22	1266, 1267, 1268	Drain-valve Assy. with adapters	1	
23	25058-101-000, 25048-089-200	2 "Diverter valve Halo, GP/Sil/GP with LED bezel	1	
24	600-4609DSG	1.5" ON-OFF Valve	0	
25	53999	Top side panel MMP 260	0	
N/A	7136, 6023, 310-0140	2 Speed Motor; 8' Cord ; Wet end 0140;	3	
N/A	7135, 300050168, 310-0140	1 Speed Motor; 14' Cord ; Wet end 0140;	0	
N/A	6167, 6024, 310-0800	Circ. pump motor; 8' Cord ; Wet end 0800;	1	
N/A	56261-01	Balboa Pack PEL2SWIM	1	
N/A	5071, 7399	Ozonator w/ Cord, Injector	1+1	
N/A	7068	Swim Spas Owner's Manual	1	
N/A	SS3A	Spa Cover	1	
N/A	1143, 1145, 1146, 1142, 1147	MRD85i Audio system, Subwoofer -4, harness WH-205, power supply 100-240vac, remote control	0	OPTION

Aquatic 11/X11 (1214-EX /1214D-EX) Export

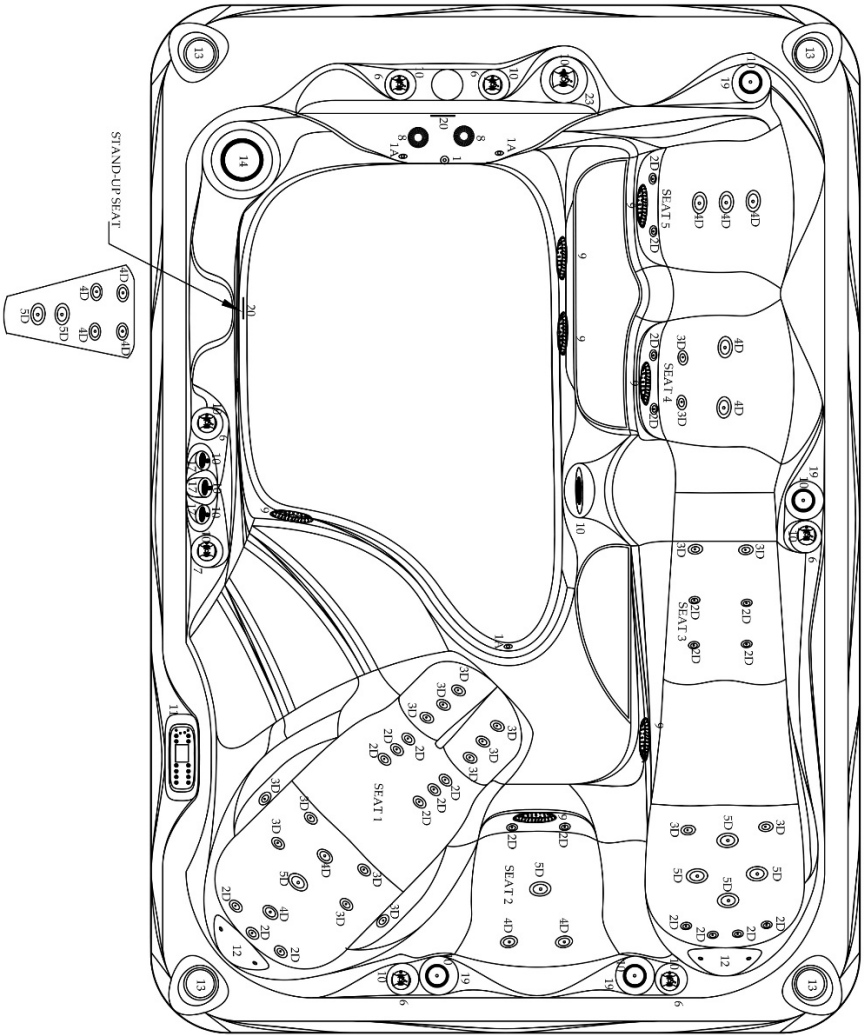

Spa Spec	
Spa Model	1214D-EX/AQ X11, 1214-EX/AQ 11-EX
Spa Dimension	89"x132"x51"
Number Of Seats	6
Water Therapy Jets	64
Water Capacity (USG/L)	620/2350
Dry Weight (LBS/KG)	1200/545
Filled Weight (LBS/KG)	6382/2895
Electrical Rating (VAC/AMP/HZ)	220-240/3x16/50
GFCI (AMP)	IEE Req.

Call-Outs				
Label	Part#	Description	Qty.	Notes
1	73199W	Nozzle wall fitting (Gr)	1	
1A	7818	Wall fitting (Gr)	3	
2D	240-1509DSG-8S, 218-5150,228-1558G	Luxe Glo Cluster storm jet, Directional, Compensator ring, Jet Body	23	
2R	240-1519DSG-8S, 218-5150,228-1558G	Luxe Glo Cluster storm jet, Pulsator, Compensator ring, Jet Body	0	
3D	240-2309DSG-8S, 718-6960,228-0308G	Luxe Glo Mini storm jet, Directional, Compensator ring, Jet Body	18	
3R	240-2329DSG-8S, 718-6960,228-0308G	Luxe Glo Mini storm jet, Twin roto, Compensator ring, Jet Body	0	
4D	240-8309DSG-8S, 218-4010,228-0408G	Luxe Glo Poly storm jet, Directional, Compensator ring, Jet Body	13	
4R	240-8319DSG-8S, 218-4010,228-0408G	Luxe Glo Poly storm jet, Rotational, Compensator ring, Jet Body	0	
5D	240-6109DSG-8S, 218-6680,228-0048G	Luxe Glo Power storm jet, Directional Compensator ring, Jet Body	8	
5M	240-6139DSG-8S, 218-6680,228-0048G	Luxe Glo Power storm jet, MassageCompensator ring, Jet Body	0	
6	25059-101-000, 25090-089-200	1" AIR Control Halo, GP/Sil/GP with LED bezel	6	
7	25056-111-000, 25030-089-200	1 "on-off valve Halo, GP/Sil/GP with LED bezel	1	
8	239-0029DSGS, 228-2000G	Thread-in Whirlpool Jet, Thread-in body w. Grommet gasket Assembly	2	
9	640-3790SGA V	251GPM Super Hi-Flo 2.5" Suction (metal)	7	
10	1219S, 1310A, 1312A, 1318A, 1315, 1317, 1338	Light Kit 5", LED contr-r, 6-LED spyder, 2-LED spyder, 9-LED light, Cables Assy	1+1+2+1+ 1+1+1	
11	52798, 12701	Topside panel ML700, overlay	1+1	
12	823690	Pillow tri-curve	2	
13	1144	Speaker 2.5" (Graphite)	4	OPTION
14	25359-097-000	100Sq.Ft Elite skim filter Assy.(Gr)	1	
15	52747, 12703	Aux. panel AX20, overlay	0	
16	7017, 7018	Tether, 3 holes plate	0	OPTION
17	210-9309S-DSG	Standard Water Feature	3	
18	3126, 3129, 3130	FRST lens, nuts, o-rings	0	
19	630-0038	Cup Holder LED	4	
20	5456	9" Hand rail ss	2	
21	1307	Row machine w. hardware	0	OPTION
22	1266, 1267, 1268	Drain-valve Assy. with adapters	1	
23	25058-101-000, 25048-089-200	2 "Diverter valve Halo, GP/Sil/GP with LED bezel	1	
24	600-4609DSG	1.5" ON-OFF Valve	0	
25	53999	Top side panel MMP 260	0	
N/A	7789, 6022, 310-0180	2 Speed Motor; 8' Cord ; Wet end 0180;	3	
N/A	7788, 300050168, 310-0180	1 Speed Motor; 14' Cord ; Wet end 0180;	0	
N/A	7794, 6024, 310-0800	Circ. pump motor; 8' Cord ; Wet end 0800;	1	
N/A	56502	Balboa Pack PGL2P3P4	1	
N/A	5071, 7399	Ozonator w/ Cord, Injector	1+1	
N/A	7068	Swim Spas Owner's Manual	1	
N/A	SS3A	Spa Cover	1	
N/A	1143, 1145, 1146, 1142, 1147	MRD85i Audio system, Subwoofer -4, harness WH-205, power supply 100-240vac, remote control	0	OPTION

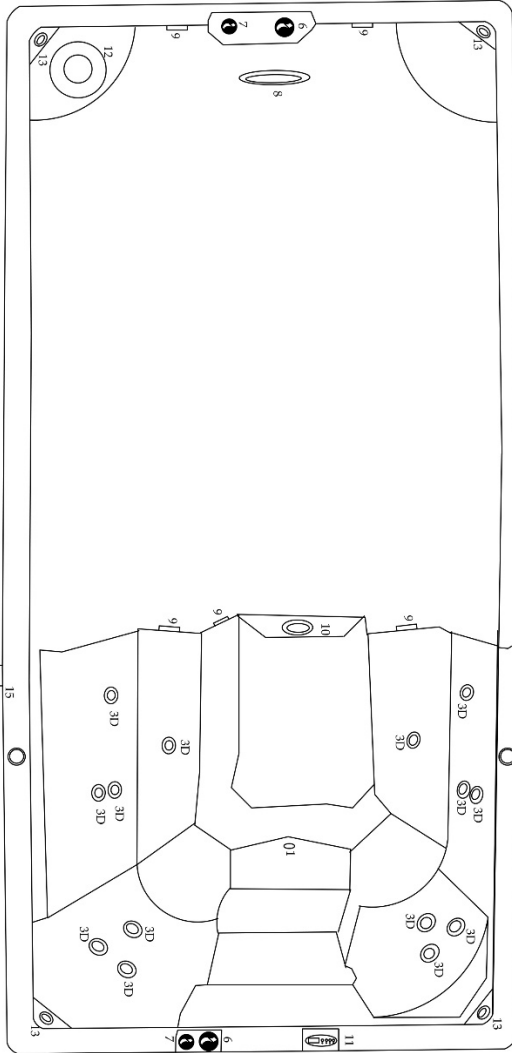

Spa Spec	
Spa Model	1303/ES14
Spa Dimension	92" x 173.5" x 50"
Number Of Seats	6
Water Jets	14
Water Capacity (USG/L)	1600/6060
Dry Weight (LBS/KG)	2300/1043
Filled Weight (LBS/KG)	15660/7103
Electrical Rating (VAC/AMP/HZ)	240/40/60
GFCI (AMP)	50

Call-Outs				
Label	Part#	Description	Qty.	Notes
1	73199W	Nozzle wall fitting (Gr)	1	
2D	240-1509DSG-8S, 218-5150,228-1558G	Luxe Glo Cluster storm jet, Directional, Compensator ring, Jet Body	0	
3D	240-2309DSG-8S, 718-6960,228-0308G	Luxe Glo Mini storm jet, Directional, Compensator ring, Jet Body	14	
3R	240-2329DSG-8S, 718-6960,228-0308G	Luxe Glo Mini storm jet, Twin roto, Compensator ring, Jet Body	0	
4D	240-8309DSG-8S, 218-4010,228-0408G	Luxe Glo Poly storm jet, Directional, Compensator ring, Jet Body	0	
5D	240-6109DSG-8S, 218-6680,228-0048G	Luxe Glo Power storm jet, Directional Compensator ring, Jet Body	0	
6	25059-101-000, 25090-089-200	1" AIR Control Halo, GP/SII/GP with LED bezel	2	
7	25056-111-000, 25030-089-200	1 "on-off valve Halo, GP/SII/GP with LED bezel	2	
8	210-5109-DSG	River Jet Assembly (GR)	1	
9	640-3790 GAV	251GPM Super Hi-Flo 2.5" Suction	5	
10	1219S, 7096A	Light Kit 5", 9-LED light	1+1	
11	53999, 7510	Topside panel VL260 w. overlay	1	
12	510-9029DSG	50Sq. Filter	1	
13	210-9309S-DSG	Standard Water Feature	0	
14	5456	9" Hand rail ss	0	
15	1266, 1267, 1268	Drain-valve Assy. with adapters	1	
16	600-4609DSG	1.5" ON-OFF Valve	0	
N/A	7136, 6022, 300051168, 310-1740SD	2 Speed Motor; 8' Cord ; 2 Speed Motor 14' Cord Wet end 1740SD;	1	
N/A	7135, 300050168, 310-0140	1 Speed Motor; 14' Cord ; Wet end 0140;	1	
N/A	6167, 6024, 310-0800	Circ. pump motor; 8' Cord ; Wet end 0800;	0	
N/A	55584	Balboa Pack VS515Z	1	
N/A	5071, 7399	Ozonator w/ Cord, Injector	1	
N/A	7068	Swim Spas Owner's Manual	1	
N/A	SS22A	Spa Cover	1	

ES 14 (1303-EX) Export

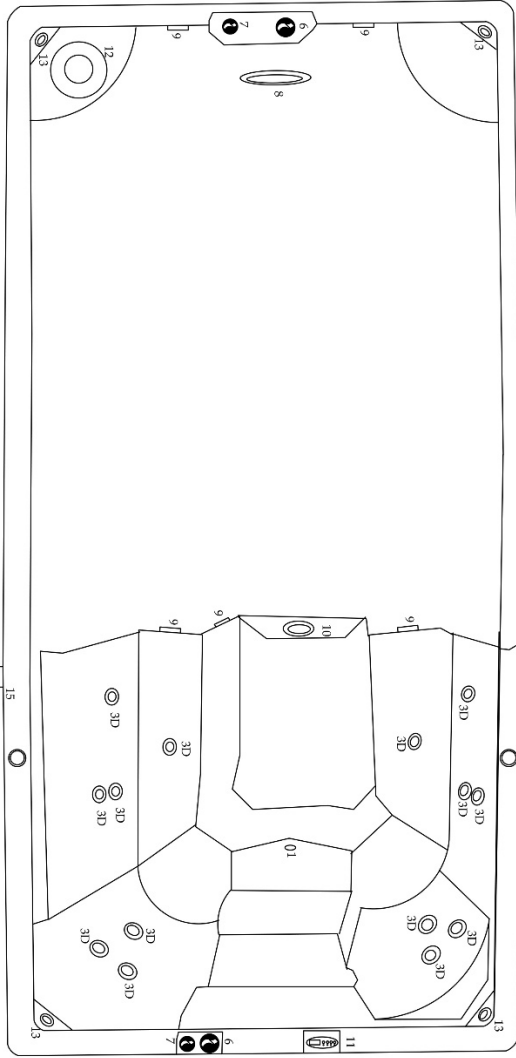

Spa Spec	
Spa Model	1303-EX/ES14-EX
Spa Dimension	92" x 173.5" x 50"
Number Of Seats	6
Water Jets	14
Water Capacity (USG/L)	1600/6060
Dry Weight (LBS/KG)	2300/1043
Filled Weight (LBS/KG)	15660/7103
Electrical Rating (VAC/AMP/HZ)	220-240/1x32/50
RCD (AMP)	IEE REQ.

Call-Outs				
Label	Part#	Description	Qty.	Notes
1	73199W	Nozzle wall fitting (Gr)	1	
2D	240-1509DSG-8S, 218-5150,228-1558G	Luxe Glo Cluster storm jet, Directional, Compensator ring, Jet Body	0	
3D	240-2309DSG-8S, 718-6960,228-0308G	Luxe Glo Mini storm jet, Directional, Compensator ring, Jet Body	14	
3R	240-2329DSG-8S, 718-6960,228-0308G	Luxe Glo Mini storm jet, Twin roto, Compensator ring, Jet Body	0	
4D	240-8309DSG-8S, 218-4010,228-0408G	Luxe Glo Poly storm jet, Directional, Compensator ring, Jet Body	0	
5D	240-6109DSG-8S, 218-6680,228-0048G	Luxe Glo Power storm jet, Directional Compensator ring, Jet Body	0	
6	25059-101-000, 25090-089-200	1" AIR Control Halo, GP/Sil/GP with LED bezel	2	
7	25056-111-000, 25030-089-200	1 "on-off valve Halo, GP/Sil/GP with LED bezel	2	
8	210-5109-DSG	River Jet Assembly (GR)	1	
9	640-3790 GAV	251GPM Super Hi-Flo 2.5" Suction	5	
10	1219S, 7096A	Light Kit 5", 9-LED light	1+1	
11	54546, 7511	Topside panel VL600S w. overlay	1	
12	510-9029DSG	50Sq. Filter	1	
13	210-9309S-DSG	Standard Water Feature	0	
14	5456	9" Hand rail ss	0	
15	1266, 1267, 1268	Drain-valve Assy. with adapters	1	
16	600-4609DSG	1.5" ON-OFF Valve	0	
N/A	7789, 6022, 300051168, 310-1750SD	2 Speed Motor; 8' Cord ; 2 Speed Motor 14' Cord Wet end 1750SD;	1	
N/A	7788, 300050168, 310-0180	1 Speed Motor; 14' Cord ; Wet end 0140;	1	
N/A	7794, 6024, 310-0800	Circ. pump motor; 8' Cord ; Wet end 0800;	0	
N/A	54509-01	Balboa Pack GS510SZ	1	
N/A	5071, 7399	Ozonator w/ Cord, Injector	1	
N/A	7068	Swim Spas Owner's Manual	1	
N/A	SS22A	Spa Cover	1	

Dual Zone 18 (2022)



Spa Spec	
Spa Model	2022/DZ18
Spa Dimension	89"x213"x58"
Spa Dimension	226cm x 541cm x 147cm
Number Of Seats	5
Water Jets	39
Water Capacity (USG/L)	2100/7949
Dry Weight (LBS/KG)	1900/862
Filled Weight (LBS/KG)	19424/8811
Electrical Rating (VAC/AMP/HZ)	Service 1: 240/1x48/60
Electrical Rating (VAC/AMP/HZ)	Service 2: 240/1x32/60

Call-Outs				
Label	Part#	Description	Qty.	Notes
1	73199W	Nozzle wall fitting (Gr)	2	
1A	7818	Wall fitting (Gr)	2	
2D	240-1509DSG-8S, 218-5150,228-1558G	Luxe Glo Cluster storm jet, Directional, Compensator ring, Jet Body	21	
2R	240-1519DSG-8S, 218-5150,228-1558G	Luxe Glo Cluster storm jet, Pulsator, Compensator ring, Jet Body	0	
3D	240-2309DSG-8S, 718-6960,228-0308G	Luxe Glo Mini storm jet, Directional, Compensator ring, Jet Body	18	
3R	240-2329DSG-8S, 718-6960,228-0308G	Luxe Glo Mini storm jet, Twin roto, Compensator ring, Jet Body	0	
4D	240-8309DSG-8S, 218-4010,228-0408G	Luxe Glo Poly storm jet, Directional, Compensator ring, Jet Body	0	
4R	240-8319DSG-8S, 218-4010,228-0408G	Luxe Glo Poly storm jet, Rotational, Compensator ring, Jet Body	0	
5D	240-6109DSG-8S, 218-6680,228-0048G	Luxe Glo Power storm jet, Directional Compensator ring, Jet Body	0	
5M	240-6139DSG-8S, 218-6680,228-0048G	Luxe Glo Power storm jet, MassageCompensator ring, Jet Body	0	
6	25059-101-000, 25090-089-200	1" AIR Control Halo, GP/Sil/GP with LED bezel	5	
7	25056-111-000, 25030-089-200	1 "on-off valve Halo, GP/Sil/GP with LED bezel	0	
8	210-5109-DSGS	River Jet Assembly	3	
9	640-3790SGA V	251GPM Super Hi-Flo 2.5" Suction (metal)	8	
10	1219S, 1310A, 1312A, 1315, 1316, 1317, 1338,	Light Kit 5", LED contr-r, 6-LED spyder, 9-LED light, Cables Assy	3+1+6+3+ 2+1+1	
11	52798	Topside panel ML700 w. overlay	1	
12	3037	Pillow corner	2	
13	3034	Pillow flat	1	
14	510-9029DSG	50Sq. Filter	3	
15	53999	Panel VL260 w. overlay	1+1	
16	7017, 7018	Tether, 3 holes plate	0	
17	210-9309S-DSG	Standard Water Feature	0	
18	3126, 3129, 3130	1" FRST lens, nuts, o-rings	0	
19	630-0038	Cup Holder LED	0	
20	5456	9" Hand rail ss	2	
20A	5457	12" Hand rail ss	0	
21	1307	Row machine w. hardware	0	
22	1266, 1267, 1268	Drain-valve Assy. with adapters	1	
23	25058-101-000, 25048-089-200	2 "Diverter valve Halo, GP/Sil/GP with LED bezel	0	
24	600-4609DSG	1.5" ON-OFF Valve	0	
N/A	7136, 6022, 310-0140	2 Speed Motor; 8' Cord ; Wet end 0140;	1	
N/A	7135, 300050168, 310-0140	1 Speed Motor; 14' Cord ; Wet end 0140;	3	
N/A	6167, 6024, 310-0800	Circ. pump motor; 8' Cord ; Wet end 0800;	1	
N/A	56261-01	Balboa Pack PEL2SWIM	1	
N/A	55940	Balboa Pack VS500Z	1	
N/A	480044	Splitter 2-speed pump to ozone-pump	0	
N/A	5071, 7399	Ozonator w/ Cord, Injector	2+2	
N/A	7068	Swim Spas Owner's Manual	1	
N/A	SS22A	Spa Cover	1	

Dual Zone 18 (2022-EX) Export



Spa Spec	
Spa Model	2022-EX/DZ18-EX
Spa Dimension	89"x213"x58"
Spa Dimension	226cmx541cmx147cm
Number Of Seats	5
Water Jets	39
Water Capacity (USG/L)	2100/7949
Dry Weight (LBS/KG)	1900/862
Filled Weight (LBS/KG)	19424/8811
Electrical Rating (VAC/AMP/HZ)	Service 1: 220-240/3x16/50
Electrical Rating (VAC/AMP/HZ)	Service 2: 220-240/1x32/50

Call-Outs				
Label	Part#	Description	Qty.	Notes
1	73199W	Nozzle wall fitting (Gr)	2	
1A	7818	Wall fitting (Gr)	2	
2D	240-1509DSG-8S, 218-5150,228-1558G	Luxe Glo Cluster storm jet, Directional, Compensator ring, Jet Body	21	
2R	240-1519DSG-8S, 218-5150,228-1558G	Luxe Glo Cluster storm jet, Pulsator, Compensator ring, Jet Body	0	
3D	240-2309DSG-8S, 718-6960,228-0308G	Luxe Glo Mini storm jet, Directional, Compensator ring, Jet Body	18	
3R	240-2329DSG-8S, 718-6960,228-0308G	Luxe Glo Mini storm jet, Twin roto, Compensator ring, Jet Body	0	
4D	240-8309DSG-8S, 218-4010,228-0408G	Luxe Glo Poly storm jet, Directional, Compensator ring, Jet Body	0	
4R	240-8319DSG-8S, 218-4010,228-0408G	Luxe Glo Poly storm jet, Rotational, Compensator ring, Jet Body	0	
5D	240-6109DSG-8S, 218-6680,228-0048G	Luxe Glo Power storm jet, Directional Compensator ring, Jet Body	0	
5M	240-6139DSG-8S, 218-6680,228-0048G	Luxe Glo Power storm jet, MassageCompensator ring, Jet Body	0	
6	25059-101-000, 25090-089-200	1" AIR Control Halo, GP/Sil/GP with LED bezel	5	
7	25056-111-000, 25030-089-200	1 "on-off valve Halo, GP/Sil/GP with LED bezel	0	
8	210-5109-DSGS	River Jet Assembly	3	
9	640-3790SGA V	251GPM Super Hi-Flo 2.5" Suction (metal)	8	
10	1219S, 1310A, 1312A, 1315, 1316, 1317, 1338,	Light Kit 5", LED contr-r, 6-LED spyder, 9-LED light, Cables Assy	3+1+6+3+ 2+1+1	
11	52798, 12701	Topside panel ML700 w. overlay	1	
12	3037	Pillow corner	2	
13	3034	Pillow flat	1	
14	510-9029DSG	50Sq. Filter	3	
15	53999	Panel VL260 w. overlay	1+1	
16	7017, 7018	Tether, 3 holes plate	0	
17	210-9309S-DSG	Standard Water Feature	0	
18	3126, 3129, 3130	1" FRST lens, nuts, o-rings	0	
19	630-0038	Cup Holder LED	0	
20	5456	9" Hand rail ss	2	
20A	5457	12" Hand rail ss	0	
21	1307	Row machine w. hardware	0	
22	1266, 1267, 1268	Drain-valve Assy. with adapters	1	
23	25058-101-000, 25048-089-200	2 "Diverter valve Halo, GP/Sil/GP with LED bezel	0	
24	600-4609DSG	1.5" ON-OFF Valve	0	
N/A	7789, 6022, 310-0180	2 Speed Motor; 8' Cord ; Wet end 0180;	1	
N/A	7788, 300050168, 310-0180	1 Speed Motor; 14' Cord ; Wet end 0180;	3	
N/A	7794, 6024, 310-0800	Circ. pump motor; 8' Cord ; Wet end 0800;	1	
N/A	56502	Balboa Pack PGL2P3P4	1	
N/A	54509-01	Balboa Pack GS500Z	1	
N/A	480044	Splitter 2-speed pump to ozone-pump	0	
N/A	5071, 7399	Ozonator w/ Cord, Injector	2+2	
N/A	7068	Swim Spas Owner's Manual	1	
N/A	SS22A	Spa Cover	1	

Swimmer 18 (2028)

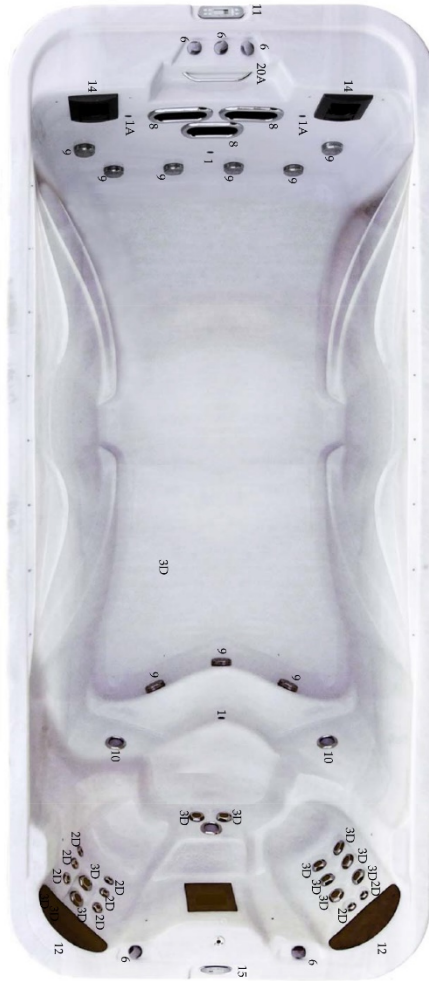

Spa Spec	
Spa Model	2028/S18
Spa Dimension	89"x213"x58"
Spa Dimension	226cm x 541cm x 147cm
Number Of Seats	3
Water Jets	18
Water Capacity (USG/L)	2180/8250
Dry Weight (LBS/KG)	1900/862
Filled Weight (LBS/KG)	20088/9112
Electrical Rating (VAC/AMP/HZ)	Service 1: 240/1x48/60
GFCI (AMP)	Service 1: 60

Call-Outs				
Label	Part#	Description	Qty.	Notes
1	73199W	Nozzle wall fitting (Gr)	2	
1A	7818	Wall fitting (Gr)	2	
2D	240-1509DSG-8S, 218-5150,228-1558G	Luxe Glo Cluster storm jet, Directional, Compensator ring, Jet Body	8	
2R	240-1519DSG-8S, 218-5150,228-1558G	Luxe Glo Cluster storm jet, Pulsator, Compensator ring, Jet Body	0	
3D	240-2309DSG-8S, 718-6960,228-0308G	Luxe Glo Mini storm jet, Directional, Compensator ring, Jet Body	10	
3R	240-2329DSG-8S, 718-6960,228-0308G	Luxe Glo Mini storm jet, Twin roto, Compensator ring, Jet Body	0	
4D	240-8309DSG-8S, 218-4010,228-0408G	Luxe Glo Poly storm jet, Directional, Compensator ring, Jet Body	0	
4R	240-8319DSG-8S, 218-4010,228-0408G	Luxe Glo Poly storm jet, Rotational, Compensator ring, Jet Body	0	
5D	240-6109DSG-8S, 218-6680,228-0048G	Luxe Glo Power storm jet, Directional Compensator ring, Jet Body	0	
5M	240-6139DSG-8S, 218-6680,228-0048G	Luxe Glo Power storm jet, MassageCompensator ring, Jet Body	0	
6	25059-101-000, 25090-089-200	1" AIR Control Halo, GP/Sil/GP with LED bezel	5	
7	25056-111-000, 25030-089-200	1 "on-off valve Halo, GP/Sil/GP with LED bezel	0	
8	210-5109-DSGS	River Jet Assembly	3	
9	640-3790SGA V	251GPM Super Hi-Flo 2.5" Suction (metal)	9	
10	1219S, 1310A, 1312A, 1315, 1316, 1317, 1338,	Light Kit 5", LED contr-r, 6-LED spyder, 9-LED light, Cables Assy	3+1+6+3+ 2+1+1	
11	52797-03, 12644	Topside panel ML900 w. overlay	1+1	
12	3037	Pillow corner	2	
13	3034	Pillow flat	10	
14	510-9029DSG	50Sq, Filter	3	
15	52747, 12703, 11589	Panel AX20 w. overlay, ext cord 7'	1+1+1	
16	7017, 7018	Tether, 3 holes plate	0	OPTION
17	210-9309S-DSG	Standard Water Feature	0	
18	3126, 3129, 3130	1" FRST lens, nuts, o-rings	0	
19	630-0038	Cup Holder LED	0	
20	5456	9" Hand rail ss	0	
20A	5457	12" Hand rail ss	1	
21	1307	Row machine w. hardware	0	OPTION
22	1266, 1267, 1268	Drain-valve Assy. with adapters	1	
23	25058-101-000, 25048-089-200	2 "Diverter valve Halo, GP/Sil/GP with LED bezel	0	
24	600-4609DSG	1.5" ON-OFF Valve	0	
N/A	7136, 6022, 310-0140	2 Speed Motor; 8' Cord ; Wet end 0140;	1	
N/A	7135, 300050168, 310-0140	1 Speed Motor; 14' Cord ; Wet end 0140;	3	
N/A	6167, 6024, 310-0800	Circ. pump motor; 8' Cord ; Wetend 0800;	1	
N/A	56261-01	Balboa Pack PEL2SWIM	1	
N/A	55940	Balboa Pack VS500Z	0	
N/A	480044	Splitter 2-speed pump to ozone-pump	1	
N/A	5071, 7399	Ozonator w/ Cord, Injector	2+2	
N/A	7068	Swim Spas Owner's Manual	1	
N/A	SS22A	Spa Cover	1	

Swimmer 18 (2028-EX) Export

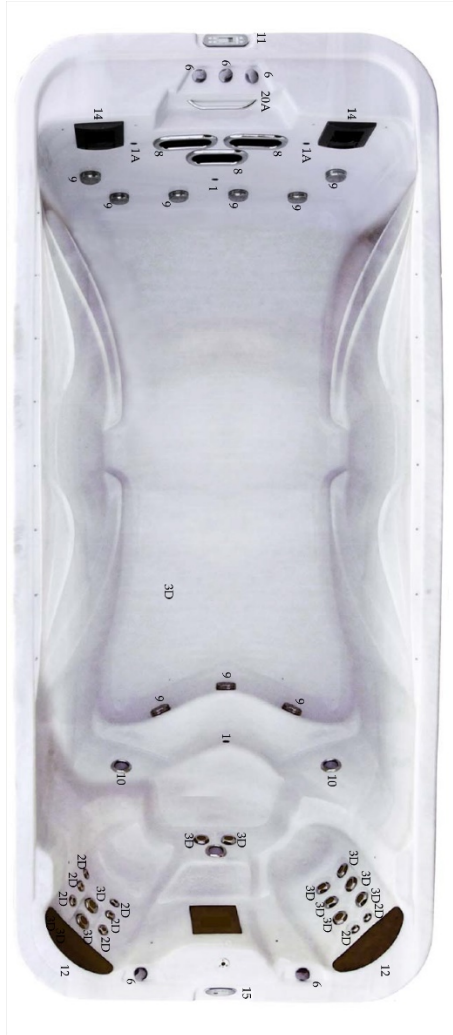

Spa Spec

Spa Model	2028-EX/S18-EX
Spa Dimension	89"x213"x58"
Spa Dimension	226cm x 541cm x 147cm
Number Of Seats	3
Water Jets	18
Water Capacity (USG/L)	2180/8250
Dry Weight (LBS/KG)	1900/862
Filled Weight (LBS/KG)	20088/9112
Electrical Rating (VAC/AMP/HZ)	Service : 220-240/3x16/50
RCD (AMP)	Service : IEE REQ.

Call-Outs				
Label	Part#	Description	Qty.	Notes
1	73199W	Nozzle wall fitting (Gr)	2	
1A	7818	Wall fitting (Gr)	2	
2D	240-1509DSG-8S, 218-5150,228-1558G	Luxe Glo Cluster storm jet, Directional, Compensator ring, Jet Body	8	
2R	240-1519DSG-8S, 218-5150,228-1558G	Luxe Glo Cluster storm jet, Pulsator, Compensator ring, Jet Body	0	
3D	240-2309DSG-8S, 718-6960,228-0308G	Luxe Glo Mini storm jet, Directional, Compensator ring, Jet Body	10	
3R	240-2329DSG-8S, 718-6960,228-0308G	Luxe Glo Mini storm jet, Twin roto, Compensator ring, Jet Body	0	
4D	240-8309DSG-8S, 218-4010,228-0408G	Luxe Glo Poly storm jet, Directional, Compensator ring, Jet Body	0	
4R	240-8319DSG-8S, 218-4010,228-0408G	Luxe Glo Poly storm jet, Rotational, Compensator ring, Jet Body	0	
5D	240-6109DSG-8S, 218-6680,228-0048G	Luxe Glo Power storm jet, Directional Compensator ring, Jet Body	0	
5M	240-6139DSG-8S, 218-6680,228-0048G	Luxe Glo Power storm jet, MassageCompensator ring, Jet Body	0	
6	25059-101-000, 25090-089-200	1" AIR Control Halo, GP/Sil/GP with LED bezel	5	
7	25056-111-000, 25030-089-200	1 "on-off valve Halo, GP/Sil/GP with LED bezel	0	
8	210-5109-DSGS	River Jet Assembly	3	
9	640-3790SGA V	251GPM Super Hi-Flo 2.5" Suction (metal)	9	
10	1219S, 1310A, 1312A, 1315, 1316, 1317, 1338,	Light Kit 5", LED contr-r, 6-LED spyder, 9-LED light, Cables Assy	3+1+6+3+ 2+1+1	
11	52797-03, 12644	Topside panel ML900 w. overlay	1+1	
12	3037	Pillow corner	2	
13	3034	Pillow flat	10	
14	510-9029DSG	50Sq. Filter	3	
15	52747, 12703, 11589	Panel AX20 w. overlay, ext cord 7'	1+1+1	
16	7017, 7018	Tether, 3 holes plate	0	OPTION
17	210-9309S-DSG	Standard Water Feature	0	
18	3126, 3129, 3130	1" FRST lens, nuts, o-rings	0	
19	630-0038	Cup Holder LED	0	
20	5456	9" Hand rail ss	0	
20A	5457	12" Hand rail ss	1	
21	1307	Row machine w. hardware	0	OPTION
22	1266, 1267, 1268	Drain-valve Assy. with adapters	1	
23	25058-101-000, 25048-089-200	2 "Diverter valve Halo, GP/Sil/GP with LED bezel	0	
24	600-4609DSG	1.5" ON-OFF Valve	0	
N/A	7789, 6022, 310-0180	2 Speed Motor; 8' Cord ; Wet end 0180;	1	
N/A	7788, 300050168, 310-0180	1 Speed Motor; 14' Cord ; Wet end 0180;	3	
N/A	7794, 6024, 310-0800	Circ. pump motor; 8' Cord ; Wet end 0800;	1	
N/A	56502	Balboa Pack PGL2P3P4	1	
N/A	55940	Balboa Pack VS500Z	0	
N/A	480044	Splitter 2-speed pump to ozone-pump	1	
N/A	5071, 7399	Ozonator w/ Cord, Injector	2+2	
N/A	7068	Swim Spas Owner's Manual	1	
N/A	SS22A	Spa Cover	1	

Notes

Warranty

Lifetime Swim Spa Structural Warranty

Premium Leisure LLC warrants the swim spa shell structure against the loss of water through the fiberglass laminate of the shell caused by defects in materials and workmanship for as long as the original purchaser owns the swim spa. Contact manufacturer if you have any questions concerning warranty issues.

Five (5) Year – Swim Spa Surface Warranty

Premium Leisure LLC Warrants the interior acrylic swim spa surface against blisters, cracks, or delaminating resulting from a defect in the acrylic surface material for a period of five (5) years from the date of purchase, based on the following formula: Suggested retail price divided by months covered (60), multiplied by months owned plus shipping = replacement cost.

Lifetime Manifold Plumbing Parts Warranty

Premium Leisure LLC warrants the plumbing manifolds, fittings, and parts to be free of defects in materials or workmanship for as long as the original purchaser owns the swim spa.

Two (2) Year – Limited Swim Spa Equipment Warranty

Premium Leisure LLC warrants the electrical equipment and components to be free of defects in materials and workmanship for a period of two (2) years on major swim spa components (electrical system, swim spa controls, motors) and two (2) years authorized field service on these items. Ninety (90) day (Parts ONLY) Limited Warranty on all optional accessory items (optional cabinets, fixtures, trim kits, skirts, CD & MP3 players, all other music and video devices, ozone, waterfall assembly, LED lighting, etc). All perishable, cosmetic or owner serviceable items, swim spa cover, light bulb, light lenses, fuses, headrests, cabinet, filters, cover-lift, swim spa drain, jet inserts, etc are warranted to be free of defects in materials and workmanship at the time of delivery. These items may be covered by a manufacturer's warranty, which may have a longer duration than this Limited Warranty. Premium Leisure LLC may serve as an agent in presenting claims under the manufacturers' warranties, but disclaims any liability there under. In the event Premium Leisure LLC provides parts to replace an alleged defective part under warranty owner will be billed for the cost thereof and credited, minus freight, upon both the defective part being returned to Premium Leisure LLC and the manufacturer of said part accepting warranty claim.

Warranty Performance

In the event of a suspected defect, under the terms of this Limited Warranty, notify manufacturer. Use all reasonable means to protect the swim spa from further damage. A service representative will provide the technical labor only, to affect the repair subject to the terms and conditions contained in this Limited Warranty. The service representative may assess reasonable travel charges. Visits to simply diagnose, troubleshoot, or inspect problems are not covered under this Limited Warranty. If we determine that repairs are not feasible due to functional defect, we reserve the right to provide a replacement part or swim spa in lieu of repair. We will replace with a part of value equal to the original purchase. In such event, owner is responsible for expenses including removal, shipping, and re-installation of the existing or replacement hot tub. The replacement swim spa or part will carry the balance of the original swim spa's warranty, if any. Either party's waiver of any breach or failure to enforce any of the terms or conditions of the warranty shall not in any way affect, limit or waive such party's right at any time to enforce strict compliance with every term and condition thereof.

Limitations and Exclusions

This Limited Warranty applies to swim spas sold after January 1, 2008. This Limited Warranty takes effect from the date the unit was originally purchased or six months from the date of manufacture whichever comes first. This Limited Warranty applies only to the Original Purchaser and terminates with any transfer of ownership. This Limited Warranty does not apply to a swim spa used for any commercial, rental, club purposes or for any swim spa used outside of the United States. The purchaser must establish the date of purchase by dated sales invoice of delivery receipt.

This Limited Warranty does not cover damage resulting from abuse, misuse, or neglect including any installation, operation, maintenance or use of the swim spa other than in accordance with the Owner's Manual of the swim spa. Damage caused by operation of the swim spa at water temperatures outside the range of 32 degrees F. and 120 degrees F., damage caused by dirty, clogged, or calcified filter cartridges, damage to the swim spa surface caused by improper use of chemicals or cleaning agents, allowing un-dissolved water sanitizing chemicals to lie on the surface, damage caused by improper pH balance or other improper water chemistry, damage caused by failure to provide even and sufficient support for the swim spa, are considered abuses and may invalidate this Limited Warranty. Damaged caused by repairs or alterations performed by anyone other than an authorized service representative is not covered. Failure caused by accidents, acts of God, nonstructural normal wear and tear, cosmetic blemishes and other causes beyond our control are excluded.

The warranty is in lieu of all other warranties, expressed or implied, including implied warranties of merchantability and fitness for a particular purpose. In no event shall manufacturer be liable for incidental or consequential damages.

DISCLAIMERS

The swim spa owner is required to provide unencumbered access to the swim spa for any warranty repair or inspection. Manufacturer shall not be liable for loss of use of swim spa or other incidental or consequential costs, expenses or damages, which may include, but are not limited to water damage, or the removal of a permanent deck or other customer fixture. Under no circumstances shall we, or any of our representatives be held liable for injury to any person or damage to any property, however arising. This warranty gives you specific legal rights and you may have other rights. No service company, or other party is authorized to change, modify, or extend the terms of this Limited Warranty in any manner whatsoever. The jurisdiction and venue for any litigation arising with respect to the transaction evidenced by this warranty shall be the Circuit Court in and for Pinellas County, Florida and Buyer hereby agrees to such jurisdiction and venue.

Premium Leisure LLC

6101 45th St. N.
St. Petersburg, FL 33714
727.573.9611

www.PremiumLeisure.com