

Premium Leisure^{LLC}

PREMIUM SPAS OWNER'S MANUAL



Premium Leisure, LLC
6101 45th St. N.
St. Petersburg, FL 33714
727.573.9611
www.PremiumLeisure.com

Part Number 7303

Revised 03/2015

Owner's Information

Dealer:

Date Purchased: _____

Company: _____

Address: _____

Telephone: _____

Installer:

Date Installed: _____

Company: _____

Address: _____

Telephone: _____

Swim Spa:

Date Delivered: _____

Model: _____

Color: _____

Serial Number: _____

Your unique Premium Spas serial number is located on a data plate outside the cabinet at ground level. When calling for service, please have your serial number in hand.

Premium Spas Owner's Manual Table of Contents

Introduction	2
Important Safety Information	3
Site Selection and Installation	8
Electrical Specifications.....	10
Electrical Services	12
Wiring Diagrams.....	15
Startup	17
Water Balancing.....	22
Topside Controls & Operation	23
Optional Audio and Docking station	28
Cover.....	30
Frequently Asked Questions	31
Troubleshooting	32
Maintenance and Care	34
Specifications	38
Notes.....	50

Important: Premium Leisure is dedicated to offering you the best in customer satisfaction and service. Be sure to read, complete, sign, and **send in the limited warranty card within 30 days of purchase or register online** at <http://premiumleisure.com/owners.shtml> to ensure you understand what you are entitled to in terms of service. If you have any questions, you can call our customer care center at 727.573.9611.

Printed in the U.S.A.

Version 1.5

Revised 03/2015

Part # 7303

Copyright © 2014, Premium Leisure LLC. All rights reserved. No portion of this manual may be reproduced in any manner without express written permission of Premium Leisure LLC. Premium Leisure™ Spas and Fitness Trainers are trademarks of Premium Leisure LLC. All other brands, product names, company names, trade names, trademarks, and service marks used are the property of their respective owners. Premium Leisure LLC may make product modifications and enhancements. Specifications may change without notice. International products may be configured differently to meet local electrical requirements. Dimensions are approximate. Patents pending.

Introduction

Your choice of a Premium brand spa from Premium Leisure LLC indicates that you are devoted to excellence. The management and staff appreciate your patronage and takes pride in the tradition of quality spas that our company represents.

To properly acquaint yourself with your spa, we suggest that you take time to read through this manual before hook up and operation. Doing so will familiarize you with important operating and safety procedures, thereby ensuring an enjoyable experience right from the start.

If you need any more information than this manual provides, feel free to visit our Web site at www.premiumleisure.com or call our customer care center, at 727.573.9611.

⚠ WARNING: This manual was written to ensure the proper use and installation of your spa. Any modifications to the procedures outlined in this manual may result in voiding your warranty.

This manual and its contents are subject to change without notice. Although we have prepared this manual as accurate as possible, we are not liable for errors or omissions; loss, injury, or damages caused by improper installation; or use of spa (improper or otherwise).

Your new spa is made with quality synthetic materials. Synthetic materials won't fade and are nearly invulnerable to mold and mildew.

We recommend, however, periodic cleaning of the jets (page 35), the pillows (page 35), the spa cover (page 34), the acrylic surface (page 36), and the cabinet (page 34).



Figure 1 – PR982

NO DIVING

DANGER: DIVING MY RESULT IN SERIOUS INJURY OR DEATH

Important Safety Information

IMPORTANT SAFETY INSTRUCTIONS SAVE THESE INSTRUCTIONS

Your physiological response to hot water depends on subjective factors such as age, health, pregnant women, temperature sensitivities, chemical sensitivities, and medical history. Always consult a physician before using a spa to understand your particular tolerance and limitations.

READ AND FOLLOW ALL INSTRUCTIONS

WARNING – To reduce the risk of injury, do not permit children to use this product unless they are closely supervised at all times.

A wire connector is provided on this unit to connect a minimum #6 (AWG) solid copper conductor between this unit and any metal equipment, metal enclosures of electrical equipment, metal water pipe, or conduit within 5 feet (1.5 m) of the unit.

**** For units with GFCI:** ⚠ **Warning** – This product is provided with a ground-fault circuit interrupter located in the main panel. The GFCI must be tested before each spa use.

Dangers

- ⚠ **RISK OF ACCIDENTAL DROWNING:** Extreme caution must be exercised to prevent unauthorized access by children. To avoid accidents, ensure that children cannot use this spa unless they are supervised at all times. Always cover the spa and use safety locks when it is not in use.
- ⚠ **RISK OF INJURY:** The VGB suction fittings in this spa are sized to match the specific water flow created by the pump. Should the need arise to replace the suction fittings or the pump, be sure that the flow rates are compatible. Never operate the spa if the suction fittings are broken or missing. Never replace a suction fitting with one rated less than the flow rate marked on the original suction fitting.
- ⚠ **RISK OF ELECTRIC SHOCK:** Install at least 5 feet (1.5 m) from all metal surfaces. As an alternative, a spa may be installed within 5 feet of metal surfaces if each metal surface is permanently connected by a minimum #6 (AWG) solid copper conductor to the wire connector on the terminal box that is provided for this purpose.
- ⚠ **RISK OF ELECTRIC SHOCK:** Do not permit any electric appliance, such as a light, telephone, radio or television, within 5 feet (1.5 m) of a spa. Do not operate such an appliance from either inside the spa or when you are wet, unless such appliances are built-in by the manufacturer.

NO DIVING

DANGER: DIVING MY RESULT IN SERIOUS INJURY OR DEATH

Warnings

⚠ TO REDUCE THE RISK OF INJURY:

- The water in a spa should never exceed 40°C (104°F). Water temperatures between 38°C (100°F) and 40°C (104°F) are considered safe for a healthy adult. Lower water temperatures are recommended for young children and when spa use exceeds 10 minutes.
 - Since excessive water temperatures have a high potential for causing fetal damage during the early months of pregnancy, pregnant or possible pregnant women should limit spa water temperatures to 38°C (100°F).
 - Before entering a spa/spa, the user should measure the water temperature since the tolerance of water temperature regulating devices varies.
 - The use of alcohol, drugs or medication before or during spa/spa use may lead to unconsciousness with the possibility of drowning.
 - Obese persons and persons with a history of heart disease, low or high blood pressure, circulatory system problems, or diabetes should consult a physician before using a spa.
 - Persons using medication should consult a physician before using a spa/spa since some medication may include drowsiness while other medication may affect heart rate, blood pressure and circulation.
- ⚠ Do not connect auxiliary components (such as headphones, cables, and additional speakers) to the stereo (if equipped).
 - ⚠ Do not use a spa immediately following strenuous exercise.
 - ⚠ Do not use your spa alone.
 - ⚠ Lock the cover on your spa when not in use.
 - ⚠ Persons with infectious diseases should not use a spa.
 - ⚠ Replace audio components only with identical components.
 - ⚠ Do not leave the CD/Stereo/MP3 access door open on the stereo (if equipped).
 - ⚠ Some types of hair dye can react with the sanitizers in your spa water causing your hair to change color. Use at your own risk.
 - ⚠ Water normally splashes out of a spa during typical use. Install an adequate perimeter that provides sound footing.
 - ⚠ Do not turn your spa on/off from a wall switch, ground fault circuit interrupter, circuit breaker, fuse, or by plugging/unplugging it.
 - ⚠ Remove all jewelry, metal, and watches from your person before entering your spa.
 - ⚠ Keep all breakables away from the spa area.
 - ⚠ Maintain water balance in accordance with instructions.
 - ⚠ Do not sit on lip of the spa.

NO DIVING

DANGER: DIVING MY RESULT IN SERIOUS INJURY OR DEATH

Warning Sign

⚠ WARNING	
REDUCE THE RISK OF ELECTROCUTION	
1. NEVER PLACE AN ELECTRIC APPLIANCE WITHIN 5 FEET OF SPA.	
REDUCE THE RISK OF CHILD DROWNING	
1. SUPERVISE CHILDREN AT ALL TIMES. 2. ATTACH SPA COVER AFTER EACH USE.	
REDUCE THE RISK OF OVERHEATING	
1. CHECK WITH A DOCTOR BEFORE USE IF PREGNANT, DIABETIC, IN POOR HEALTH, OR UNDER MEDICAL CARE. 2. EXIT IMMEDIATELY IF UNCOMFORTABLE, DIZZY, OR SLIPPERY. SPA HEAT CAN CAUSE HYPERTHERMIA AND UNCONSCIOUSNESS. 3. SPA HEAT IN CONJUNCTION WITH ALCOHOL, DRUGS, OR MEDICATION CAN CAUSE UNCONSCIOUSNESS.	
WHEN PREGNANT, SOAKING IN HOT WATER FOR LONG PERIODS CAN HARM YOUR FETUS. MEASURE WATER TEMPERATURE BEFORE ENTERING.	
1. DO NOT ENTER SPA IF WATER IS HOTTER THAN 100° F (38° C). 2. DO NOT STAY IN SPA FOR LONGER THAN 10 MINUTES.	
⚠ AVERTISSEMENT	
RÉDUISEZ LE RISQUE D'ÉLECTROCUTION	
1. NE PLACEZ JAMAIS UN APPAREIL ÉLECTRIQUE À UNE DISTANCE DE MOINS D'UN MÈTRE ET DEMI DU SPA.	
RÉDUISEZ LE RISQUE DE NOYADE DES ENFANTS	
1. SUPERVISEZ LES ENFANTS EN TOUT TEMPS. 2. FIXEZ LE COUVERCLE DU SPA APRÈS CHAQUE UTILISATION.	
RÉDUISEZ LE RISQUE DE SURCHAUFFE	
1. CONSULTEZ UN MÉDECIN AVANT D'UTILISER SI VOUS ÊTES ENCEINTE, DIABÉTIQUE, EN MAUVAISE SANTÉ OU SOUS SURVEILLANCE MÉDICALE. 2. SORTEZ IMMÉDIATEMENT DU SPA SI VOUS VOUS SENTEZ INCONFORTABLE, ÉTOURDI OU ENDORMI. LA CHALEUR DU SPA PEUT CAUSER DE L'HYPERTHERMIE ET UN ÉVANOUSSEMENT. 3. LA CHALEUR DU SPA AJOUTÉE À DE L'ALCOOL, DES DROGUES OU DES MÉDICAMENTS PEUT CAUSER UN ÉVANOUSSEMENT.	
LORSQUE VOUS ÊTES ENCEINTE, TREMPER DANS DE L'EAU CHAUDE PENDANT DE LONGUES PÉRIODES PEUT CAUSER DES DOMMAGES À VOTRE FŒTUS. MESUREZ LA TEMPÉRATURE DE L'EAU AVANT D'ENTRER.	
1. N'ENTREZ PAS DANS LE SPA SI LA TEMPÉRATURE DE L'EAU EST SUPÉRIEURE À 38° C (100° F). 2. NE RESTEZ PAS DANS LE SPA PENDANT PLUS DE 10 MINUTES.	

Warning Sign Must Be Posted – The red WARNING sign like the one shown is packed with your new spa. This sign must be posted in a prominent place in close proximity to the spa installation site immediately upon completion of spa installation.

Figure 2 – Warning Sign

Important: It is extremely important that this sign be permanently placed in clear view of persons using the spa. Occasional spa users may not be aware of some of the dangers hot water poses to pregnant women, small children, seniors, and people under the influence of alcohol. If you did not receive a warning sign or your sign has become damaged, please call your local dealer for a replacement.

Hyperthermia

To reduce the risk of injury, the water temperature in a spa should never exceed 104°F (40°C). Water temperatures between 100°F (38°C) and 104°F (40°C) are considered safe for a healthy adult. Lower water temperatures are recommended for young children, senior citizens, persons with sensitivities, and when spa use exceeds 10 minutes.

WATER TEMPERATURE IN EXCESS OF 100°F (38°C) MAY BE INJURIOUS TO YOUR HEALTH.

Hyperthermia occurs when the internal temperature of the body reaches a level several degrees above the normal body temperature of 98.6°F (37°C). The symptoms of hyperthermia include drowsiness, lethargy, and an increase in the internal temperature of the body. The effects of hyperthermia include:

- ⚠ Unawareness of impending hazard
- ⚠ Failure to perceive heat
- ⚠ Failure to recognize the need to exit spa
- ⚠ Physical inability to exit spa
- ⚠ Fetal damage in pregnant women
- ⚠ Unconsciousness and danger of drowning

If you sense any of the symptoms of hyperthermia, safely exit the spa immediately.

SAVE THESE INSTRUCTIONS

Basic Safety Guidelines

Your hot tub is meant to be enjoyable, healthful, and relaxing. Below are some basic safety guidelines to follow every time you use your hot tub.

- Always check the temperature of your hot tub before entering. High water temperatures can be hazardous to your health.
- Persons suffering from heart disease, diabetes, high or low blood pressure, and pregnant women should consult a doctor before using your hot tub.
- Persons under the influence of medication, drugs, or alcohol should not be allowed into your hot tub.
- Remove all jewelry, metal, and watches from your person before entering your hot tub.
- Do not allow children to use your hot tub without continuous supervision of an adult.
- Do not use your hot tub alone.
- Test the ground fault circuit interrupter (GFCI) breaker prior to using your hot tub each time to ensure it operates properly.
- Any electrical devices near your hot tub must be GFCI protected and out of reach from inside the hot tub.
- Keep all breakables away from the hot tub area.
- Lock the cover on your hot tub when not in use.
- Enter and exit the hot tub slowly. Wet surfaces can be slippery.
- Prolonged immersion can be hazardous to your health.
Maintain water chemistry in accordance with manufacturer's instructions.
- The hot tub is not to be used by persons with reduced physical, sensory or mental capabilities, or lack of experience and knowledge, unless they have been given supervision or instruction
- Do not sit on lip of spa.

NO DIVING DANGER: DIVING MY RESULT IN SERIOUS INJURY OR DEATH

Basic Water Quality Guidelines

- *During the initial filling of the spa, add a sequestering agent to combat suspended minerals in the water. Allow water to circulate and filter for at least 12 hours before adding any other chemicals.*
- *Test water for PH, total Alkalinity, and Calcium hardness. The PH should be 7.2-7.8 and the total Alkalinity 80-180 PPM. Calcium hardness levels should be maintained between 150 and 400 PPM. Adjust PH and total Alkalinity (TA) utilizing the directions on the chemical bottles. Wait 15-30 minutes, test and adjust if necessary.*
- *Add 2 ounces of concentrated chlorinating granules (sodium Dichlor-s-triazinetreone) on initial start up to begin sanitizing the spa water. It is important not to add the chlorinating granules until the PH, alkalinity and calcium hardness have been adjusted to their proper levels.*
- *Check spa water with test strip for proper sanitation levels and adjust accordingly to the proper levels. Free chlorine should be 2-4 PPM.*
- *We recommend a minimum level of 2 PPM residual chlorine be maintained in spa water. Be sure the pumps are running when adding chlorine or non chlorine shock/oxidizer.*
- *Add 1 ounce of non-chlorine shock/oxidizer or ½ ounce of bromine to the spa water after each spa use.*

For spas Equipped with Audio Components

Audio components are optional and not available on all models.

 **WARNING: Prevent Electrocuton:** Do not connect any auxiliary components – for example, cable, additional speakers, headphones, etc., – to the system.

 **Caution: Risk of Electric Shock:** Do not leave audio compartment door open. Replace audio components only with identical components.

Site Selection and Installation

Proper planning is an important consideration when installing your new spa. Site selection is a critical step and requires serious thought. Planning ahead makes the installation process easier. The following information is provided to assist you in site preparations.

- 1) Always comply with local building codes and obtain any necessary permits. You may also need to consult with an engineer to address your specific design needs.
- 2) Contact an electrician to assess your electrical needs, install wiring, and assure a safe operation.
- 3) Position your spa with proper access to water, drainage, and electricity.
- 4) For **external installations**, place your spa on a uniform solid, flat surface designed to properly support its weight. For external installations, at least 4" (10cm) thick concrete pad should be used. See below dimensions for conduit entry location for your model hot tub.
- 5) For **internal installations**, check the load carrying capabilities of the floor on which the spa will reside. Most homes meet the requirement of 80-90 Lbs per square foot. The ceiling should be more than 10 feet high (for safe entry and use), the floor should have a drain for splash over and the room should have a window or exhaust fan with humidistat for ventilation. If this is not possible, indoor/outdoor carpeting and the use of a dehumidifier while the cover is off should be adequate.
- 6) Assure that your spa will fit into the space you have chosen and the delivery route will accommodate its large size. Provide adequate ventilation for the humidity created by your spa. In most cases, a Spa Hard Cover is sufficient.
- 7) Protect the pumps and all equipment from the weather by ensuring the cabinet panels are secure at all times.
- 8) Allow 36 inches (1 meter) of unobstructed access to all sides of your spa for normal servicing. Consider positioning your spa out of or adequately protecting it from the wind. Just as people can get cold on cool/windy days, so can your spa. Windy environments can significantly increase operating costs.

The following dimensions can be used to determine the proper location of submerged conduits in concrete slab installations. All dimensions are made from the outside of the hot tub's frame with the access panels removed. The topside control panel is shown at bottom of diagram for reference.

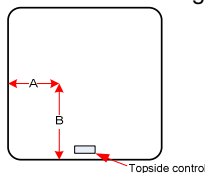

Figure 3 – Conduit Entry Location Reference Points

Model	Dimension A	Dimension B
PR982 (1210)	32"(80cm)	12"(30cm)
PR881(1215)	28" (70 cm)	12" (30 cm)
PR761(1216)	28"(70cm)	13"(33cm)

Table 1 – Conduit Entry Location Dimensions

Electrical Specifications

Important – Qualified and licensed electricians must perform all electrical hookups. The following specifications must be followed in order to ensure proper performance and safety.

⚠ WARNING: Starting an incorrectly wired spa could cause severe damage to the mechanical equipment or even bodily harm. Have your licensed electrician verify GFCI (or RCD) wiring with the diagrams on pages 12-23 prior to starting the spa or call the technical support line at 727.573.9611.

⚠ Caution: Failure to abide by specifications listed may result in damage to the equipment and will void the warranty. All spas must be wired with the appropriately sized wiring. Failure to do so will cause equipment damage and will not be covered under your warranty. All spas must be over current protected with a built-in GFCI (or RCD) in the service panel.

Spa Model	Control (controller, spa panel)	Volts/ Frequency VAC/HZ	AMPS	GFCI/RCD AMPS	Wire size required
PR982/1210PR	PEL2P3S2, ML700 BP2000, Spa Touch*	240/120/60	48	60	4 Wire #6
PR881/1215PR	PEL2P3S2, ML700 BP2000, Spa Touch*	240/120/60	48	60	4 Wire #6
PR761/1216PR	PEL2P3S2, ML700 BP2000, Spa Touch*	240/120/60	48	60	4 Wire #6

R982-EX/ 1210PR-EX	PGL2P3P4, ML700, BP2100, Spa Touch*	220-240/50	1x32 or 3x16	IEE Wire Req.	3x6mm ² or 5x2.5mm ²
PR881-EX/ 1215PR-EX	PGL2P3P4, ML700, BP2100, Spa Touch*	220-240/50	1x32 or 3x16	IEE Wire Req.	3x6mm ² or 5x2.5mm ²
PR761-EX/ 1216PR-EX	PGL2P3P4, ML700, BP2100, Spa Touch*	220-240/50	1x32 or 3x16	IEE Wire Req.	3x6mm ² or 5x2.5mm ²

***For Spas with Spa Touch see included 7876B insert.**

Table 2 – Domestic/Export (in Gray) Electrical Specification Chart

NOTE: Please consult your applicable electrical codes related to the size of conductors as they may vary from what is stated above. Take into consideration the length of cable as well and increase as required.

⚠ WARNING: Disconnect electrical power before servicing. Before obtaining access to terminals, all supply circuits must be disconnected.

⚠ WARNING: Test the GFCI (or RCD) before each use.



Our spas are certified by Intertek Testing, SNAa Ltd. Ontario, Canada to CSA-C22.2 No. 218.1-M89 and ANSI/UL 1563 standards.



Wiring Diagram of electrical services

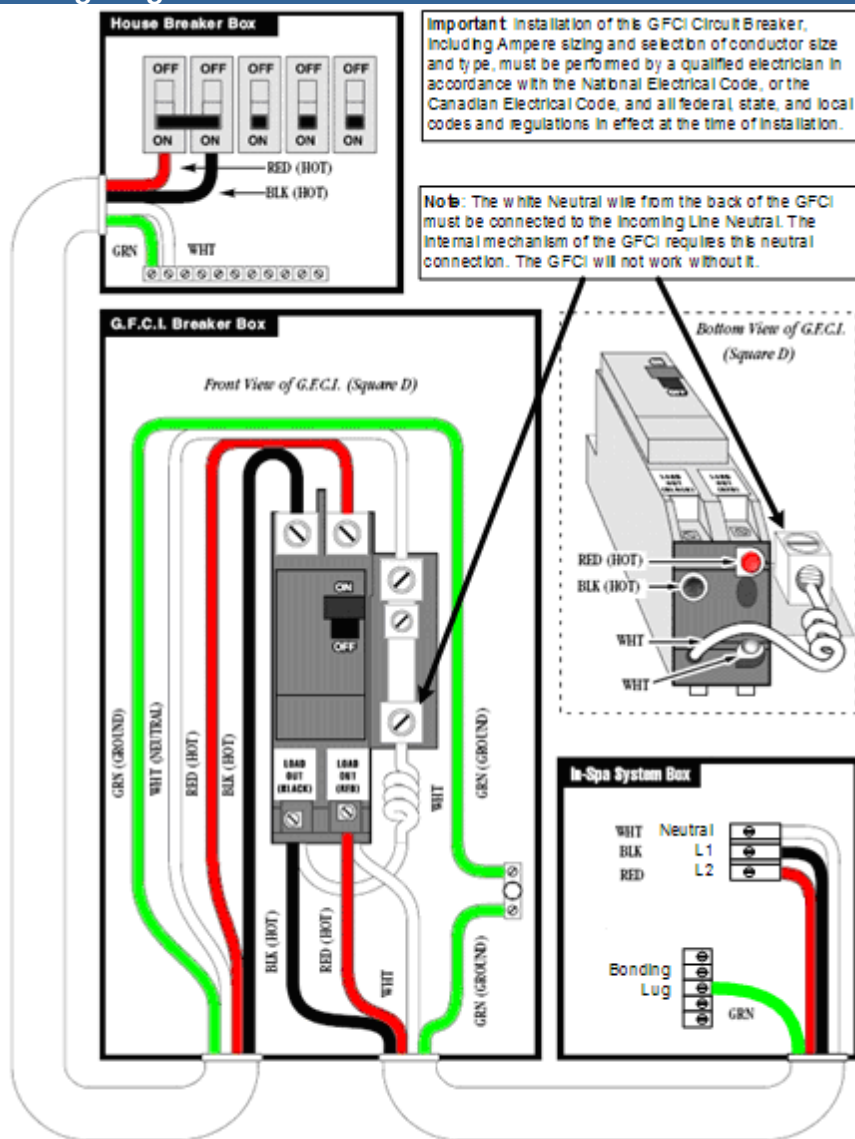

Figure 4 – Electrical Service for all domestic Single-phase 240vac models

See wire size chart in Table 2

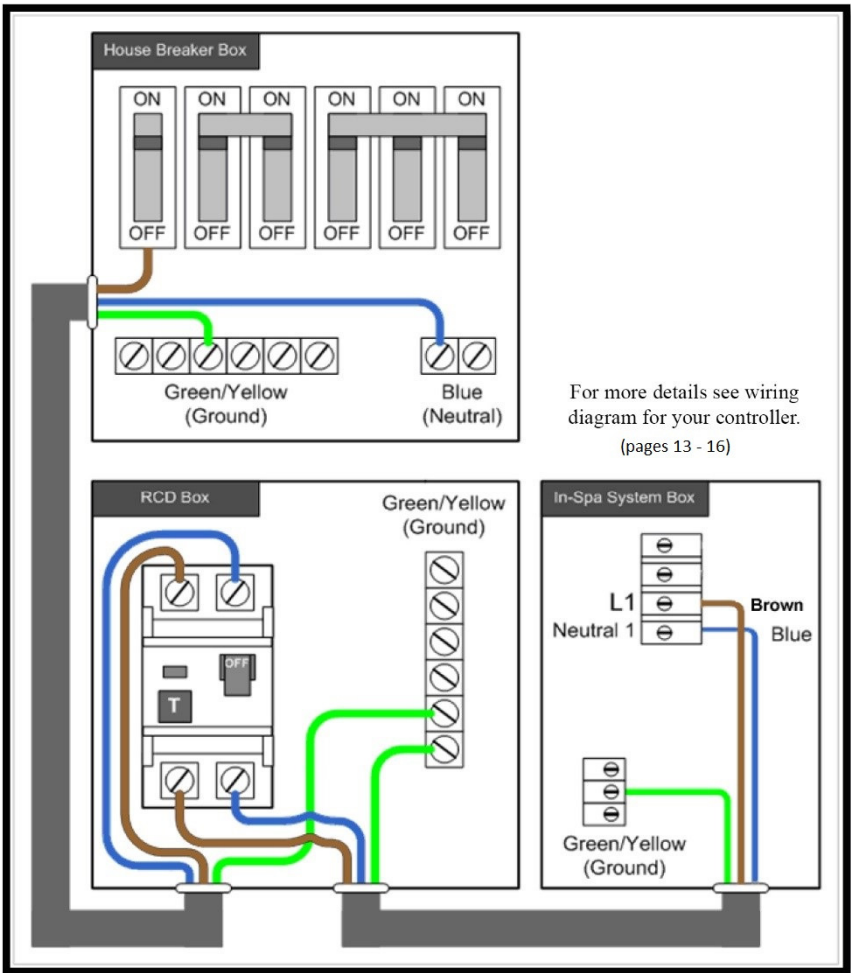
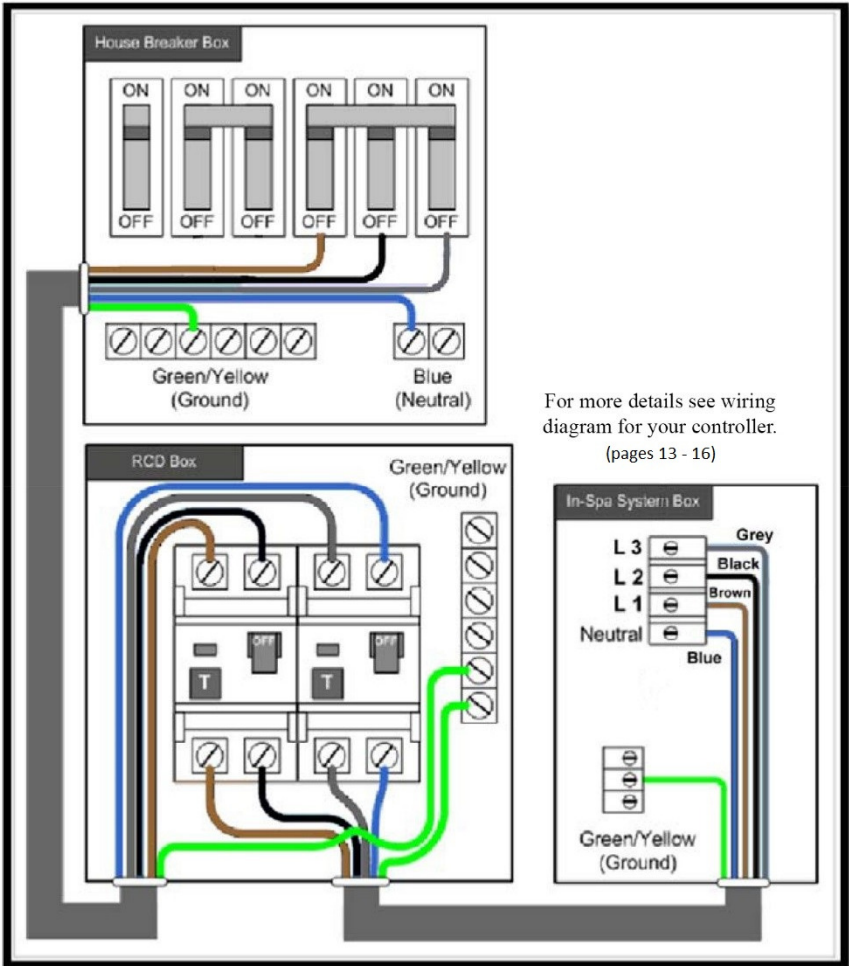

Figure 5 – Electrical Service for export models, single service 1x32A, applications.

See wire size chart in Table 2



For more details see wiring diagram for your controller. (pages 13 - 16)

Figure 6 – Electrical Service for three phase, 3x16A applications.

See wire size chart in Table 2

Wiring Diagram Spa Controllers

PEL2P3S2 — PN 56424

ML(MAIN)PANELS
J70, J71 or J72

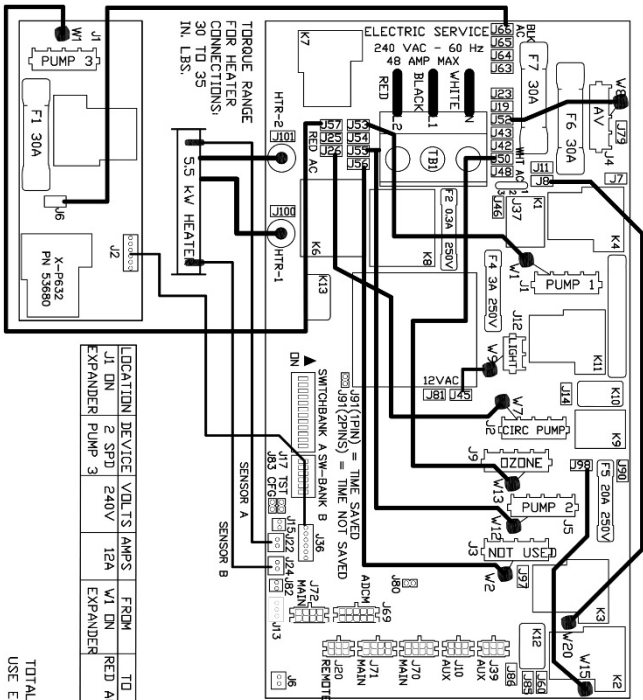

LOCATION	DEVICE	VOLTS	AMPS	FROM	TO
J1 DN	2 SPD	240V	12A	V1 DN	RED AC
J1 DN	PUMP 3	240V	12A	V1 DN	RED AC
J2	EXPANDER	240V	12A	V1 DN	RED AC

TOTAL OUTPUT AMP DRAW NOT TO EXCEED MAX INPUT RATING OF SPA
USE EARTH GROUND CONNECTIONS AS INDICATED INSIDE THE SYSTEM ENCLOSURE

**J37 MUST ALSO BE SET ON PINS 2 AND 3 FOR A 12V SPA LIGHT

J83 ON 2 PINS SWITCHBANK A OFF (DOWN) SWITCHBANK A ON (UP)

TEST MODE OFF	TEST MODE ON
▶ A1	▶ A1
▶ A2	▶ A2
▶ A3	▶ A3
▶ A4	▶ A4
▶ A5	▶ A5
▶ A6	▶ A6
▶ A7	▶ A7
▶ A8	▶ A8
▶ A9	▶ A9
▶ A10	▶ A10
▶ A11	▶ A11
▶ A12	▶ A12

SWITCHBANK A OFF (DOWN)	SWITCHBANK B ON (UP)
▶ B1	▶ B1
▶ B2	▶ B2
▶ B3	▶ B3
▶ B4	▶ B4
▶ B5	▶ B5
▶ B6	▶ B6

ALL UNUSED SWITCHES SHOULD BE OFF

LOCATION	DEVICE	VOLTS	AMPS	FROM	TO
J1	2 SPD P1	240V	12A	W1	RED AC
J2	CIRC PUMP	240V	4A	W7	RED AC
J3	NOT USED	240V	9A	W2	RED AC
J4	AV	120V	9A	W8	WHIT AC
J5	2 SPD P2	240V	12A	W12	RED AC
J9	DZONE	120V	1A	W13	WHIT AC
J12	HEATER	240V	5.5kW	W9	WHIT AC
J16	HR	240V	5.5kW	HR TERM	W1/2

CONNECT ONLY TO CIRCUITS PROTECTED BY A CLASS A GFCI.
A DISCONNECT MEANS MUST BE INSTALLED WITHIN SIGHT FROM THE EQUIPMENT AND AT LEAST 5 FEET (1.52 M) FROM THE INSIDE WALLS OF THE POOL, SPA, OR HOT TUB.
TORQUE RANGE FOR MAIN TERMINAL BLOCK (TB1):
27-30 IN. LBS.

USE COPPER CONDUCTORS ONLY.
EMPLOYER REQUIREMENT?
DES CONDUCTEURS DE CUIVRE.
#6 AVG MIN. WIRE = 75°
FOR SUPPLY CONNECTIONS.
USE CONDUCTORS SIZED ON THE BASIS OF 60% CAPACITY BUT RATED MINIMUM OF 75%.

Figure 7

PGL2P3P4 - PN 56502 (PAGE 1)

MIL (MAIN) PANELS
J70, J71 or J72

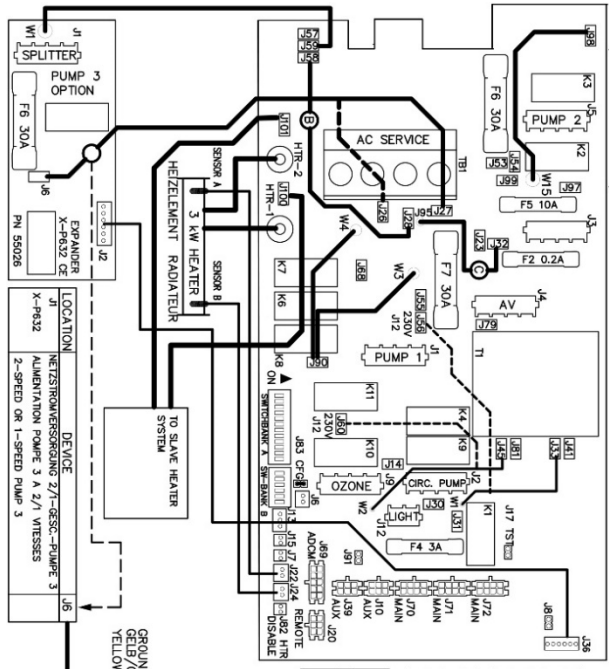

ORC PUMP BEHAVIOR	A6	A7
NO ORC PUMP	OFF	OFF
24-HR ORC	OFF	ON
3T SHUT-OFF	ON	OFF
FILTERS/FOLLS ONLY	ON	ON
PUMP 2 BEHAVIOR	A8	A9
NO PUMP 2	OFF	OFF
ON / OFF	OFF	ON
2-SPEED	ON	OFF
PUMP 5 BEHAVIOR (SETS 4)	B4	B5
NO PUMP 5	OFF	OFF
ON / OFF WITH X-F632 PIN 2	ON	ON

SWITCHBANK A OFF (DOWN)	▲ A1	TEST MODE ON
	▲ A2	ADD 1 HS PUMP WITH HEAT
	▲ A3	ADD 2 HS PUMPS WITH HEAT
	▲ A4	DON'T ADD 4 HS PUMPS WITH HEAT
	▲ A5	W/20 SCRAMMING ON
	▲ A6	SEE ORC PUMP BEHAVIOR
	▲ A7	SEE ORC PUMP BEHAVIOR
	▲ A8	SEE PUMP 2 BEHAVIOR
	▲ A9	SEE PUMP 2 BEHAVIOR
	▲ A10	EDIT MENU (NORMALLY OFF)
	▲ A11	SPECIAL AMPERAGE RULE ON*
	▲ A12	MEMORY RESET
SWITCHBANK B ON (UP)	▲ B1	SEE PUMP 3 BEHAVIOR
	▲ B2	SEE PUMP 3 BEHAVIOR
	▲ B3	SEE PUMP 3 BEHAVIOR
	▲ B4	SEE PUMP 5 BEHAVIOR
	▲ B5	SEE PUMP 5 BEHAVIOR
	▲ B6	NOT ASSIGNED

* WITH SPECIAL AMPERAGE RULE ON, BLOWER WILL SHUT OFF WHEN 2ND HIGH SPEED PUMP IS ON.

ALL UNUSED SWITCHES SHOULD BE OFF

PUMP 3 BEHAVIOR	B1	B2	B3
NO PUMP 3	OFF	OFF	OFF
DN / OFF (ON BOARD)	OFF	OFF	ON
DN / OFF (X-F632)	OFF	ON	ON
DN / OFF (X-F632)	ON	OFF	OFF
2-SPEED (X-F632)	ON	OFF	ON
AC SERVICE	WIRE (A) (C) (D) (E) (F) (G) (H) (I) (J) (K) (L) (M) (N) (O) (P) (Q) (R) (S) (T) (U) (V) (W) (X) (Y) (Z)	REMOVE	REMOVE
400V 3P / 24kVA	J56 TO J83	J59 TO J89	TO J88
230V 1P / 14kVA	J85 TO J88	TO J82	

Figure 8-A

PGL2P3P4 (PAGE 2) – PN 56502

3 X 16A

L1 (BR)|L2 (BR)|L3 (BR)|N (BL)

L1 — 230VAC 32A — N
 BROWN BLUE
 BRAUN BLAU
 BRUN BLEU

Settings (Software Configured)

LOCATION	DEVICE
J1	NETZSTROMVERBODEN 2-GESCHW.-PUMPE 1 ALIMENTATION PUMPE 1 A 2 VITESSES 2-SPEED PUMP 1
J2	NETZSTROMVERBODEN 2-GESCHW.-PUMPE 2 CIRCULATION CIRC PUMPE
J3	1/2-SPEED PUMP 1-1/2 SPEED PUMP 1
J4	1/2 HEATER STRÖM/LEBENSLEBE HEATER
J5	NETZSTROMVERBODEN 1/2-GES.-PUMPE 2 ALIMENTATION PUMPE 2 A 1/2 VITESSES 1/2-SPD P2
J9	GENERATOR/GENERATOR GENERATOR/GENERATOR
J10	GENERATOR/GENERATOR GENERATOR/GENERATOR
J12	BELEUCHTUNG/ECLAIRAGE MAIN HYDRO SPA LIGHT

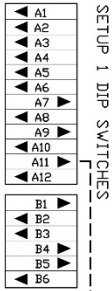

2-SPEED PUMP 1, 1-SPEED PUMP 2, 1-SPEED PUMP 3,
 1-SPEED PUMP 5/JETS 4, CIRC PUMP, DZONE, LIGHT, A/V (HDT),
 3.0 KW HEATER, ML900 MAIN PANEL, AX20A144 AUXILIARY PANEL

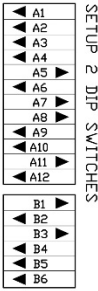

2-SPEED PUMP 1, 2-SPEED PUMP 2, 2-SPEED PUMP 3,
 CIRC PUMP, DZONE, LIGHT, A/V (HDT), 3.0 KW HEATER,
 ML700 MAIN PANEL, AX20A144 AUXILIARY PANEL

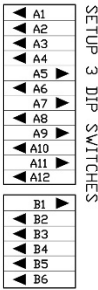

2-SPEED PUMP 1, 1-SPEED PUMP 2, 1-SPEED PUMP 3,
 CIRC PUMP, DZONE, LIGHT, A/V (HDT), 3.0 KW HEATER,
 ML700 MAIN PANEL

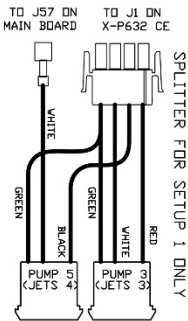
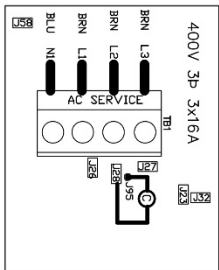
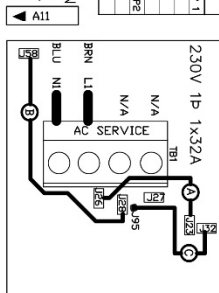

FIR SUPPLY CONNECTIONS, USE COPPER CONDUCTORS ONLY.
 USE CONDUCTORS SIZED ON THE EMPLOYER'S UNDERMENT
 BASIS OF 60°C AMPACITY BUT DES CONDUCTEURS DE CUIVRE.
 RATED MINIMUM OF 90°C.

TORQUE RANGE FOR
 MAIN TERMINAL BLOCK (TB1):
 27-30 IN. LBS.
 (31.1-34.5 kg cm)

Figure 8-B

Startup

Important – Read these step-by-step startup procedures before starting your spa. Failure to follow any of these steps listed may result in damage to the equipment and may void your warranty.

Note: If you are unsure of any of the above startup procedures, please call our customer care center at 727.573.9611. For best results, read each step in its entirety before proceeding.

⚠ Caution: Running the spa pump dry (without water running through it) can cause IMMEDIATE damage and will void the warranty! Be sure that the spa is installed properly in accordance with the instructions in this manual.

Refer to the following picture for an explanation of your spa's controls, components, and technical terms. Note that not all models have all features and components.

Figure 9 – Spa Callouts (PR982 Shown)

Before Adding Water

Before adding water, go through these simple steps now to prevent common issues when setting up your spa for the first time. Verify that the following have all been rechecked.

1. Turn off all power to the spa at the main breaker panel.
2. Open the side panels to access the internal components.
3. Check that all slide valves are opened (T-handles pulled out) to the heater and all pumps.
4. Check that there are no obvious signs of loose wires or broken pipes.

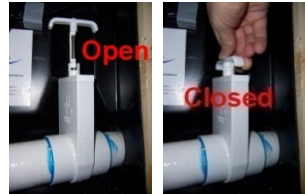

Figure 10 - Valve Open/Closed

5. Check that the two heater unions are hand tight.

⚠ Caution: Do not use a wrench. Over-tightening may cause damage to unions and gaskets, which will not be covered under warranty.

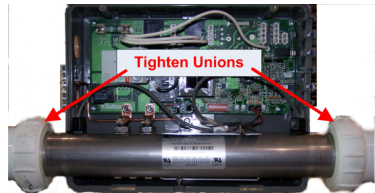

Figure 11 - Unions Tight

6. Check that the unions on all pumps are tight.
7. Clean out any foreign debris from within the service access area or inside of the spa itself.
8. With the drain open and filters removed, thoroughly rinse out the spa with warm water until the drained water runs clear. Run water through the filtration housing and jet lines to remove any incidental dust, dirt, and debris that may have accumulated during shipment or installation. Drain all water completely.
9. Make sure that the spa drain valve is closed and the cap is on tight (Figure 18).
10. Install the filter(s) in the filtration housing.
11. Check that all of the spa jets are open (turned full counter-clockwise).
12. Now is the best time to clean and polish the surfaces of your spa (see page 36).

Filling Your Spa

Now it's time to fill your spa with water. Do not turn on the electricity yet until the spa is completely filled. To properly fill your spa:

1. Make sure that the filters (in the filtration housing) are gently screwed into place. Turn them clockwise until they stop being careful not to over-tighten them (this avoids cracking the filter).
2. Connect a standard garden hose to a faucet with regular cold tap water (not softened water or hot water).



Figure 12 – Filtration Housing

⚠ Caution: The water from your hot water tank should not be used to fill the spa.

3. Put the pre-filter (if equipped*) on the other end of the hose, point the pre-filter into a suitable drain, turn on the water, and allow any sediment to be flushed down the drain. Once the water stream runs clear, turn off the hose.
4. Put the pre-filter (if equipped) into the filtration housing and turn on the hose.
5. **Fill slowly.** If too much water pressure is used, foaming water can force air into the pipes and cause startup problems.

Important: To assure that the pump is properly primed, **fill the spa through the filter housing only.**

6. Fill the spa until the water level is about 1/2" above all jets (or about 1/2" below the pillow). Do not over fill.

Note: Every person entering a spa displaces a given volume of water, so adjust water level to the number of people regularly using the spa. Turn off the hose and check again for any small leaks.

Draining Your Spa

We recommend draining your water every 6-12 months.

1. Locate nearest drain facility (laundry tub, floor drain, lawn, shower, etc).
2. Turn off the breaker(s) to spa and disconnect electrical power to all equipment.
3. Remove the filter cartridge(s) from spa filtration housing.
4. Locate the drain valve at the side of your spa cabinet.
5. Attach a garden hose to the drain-valve(s), open the drain-valve and drain spa.
6. Monitor the spa while it drains.
7. Use another garden hose to wash down interior surface as the spa continues to drain.

* Pre-filters are available by calling 877.530.PARTS or 727-573-9611

8. Completely flush the old water from plumbing lines, allow fresh water to fill into foot well area while the old water continues to be drained. When the water from the drain hose turns clear close drain-valve.

Note: For faster draining, you may use a sump pump or siphon.

Operational Checking Your Spa

 **Caution:** Do not turn on any pump until your spa is properly filled with water. Running any pump without water in your spa can cause IMMEDIATE damage, which is not covered under warranty!

By now you have rechecked your spa's mechanical connections and filled it with water to about 1/2" above all jets by adding cold tap water through the pre-filter (if equipped). Turn on power to the spa at the main breaker panel and test the operation of the electrical system. If you encounter a problem, please reference to the troubleshooting guide on page 32.

Before applying voltage to power-up your spa, it is very important that you understand the sequence of events that occur when the system is activated in order that pumps can be primed efficiently and damage can be avoided.

1. Turn on the breaker and test the spa operation of the Ground-Fault Circuit Interrupter (GFCI) breaker by pushing the small button. This should automatically trip the spa's circuit breaker.

 **DANGER:** If this breaker does not trip, immediately call your electrician. Do not use your spa!

Only if pushing this button successfully trips this circuit breaker should you reset this breaker and proceed to the next step.

2. Turn on power to the spa.
3. The spa will go through its priming mode. Go to the topside control panel (see pages 23-25 for details) and follow the control instructions for your particular model spa to activate the pumps. The spa first goes into a 5-6 minute Priming mode, indicated by "Pr" message on display. Water heating is disabled during priming. The purpose of the priming mode is to help insure that jet pumps have been primed with water and ready to operate. It may be necessary in some instances to bleed air from the jet pumps in your spa if after priming mode the spa pumps run but do not move water. The pump may have an air lock. To exit Priming mode and begin normal spa operation, press "Up" or "Down" button. The circulation pump starts and water flows through the return jets.
4. After energized each of spa pump (see pages 23-25 for details) you should hear the each pump turn on on high speed and water circulating through the jets running water with each pump of spa.

 **Caution:** If water is not flowing from the jets after 2 minutes, turn the power off at the main panel and bleed air from the system (Figure 17). Turn the power on again. Sometimes momentarily turning the pump off/on will help to prime. Only do this no more

than 4 times.

5. If the water is running smoothly through the water lines, open the air control valve to the jets located on spa lip and you should see an increase in jet pressure. Check and adjust the water and air flow of each spa seat if necessary.

An air mixture intensifies the level of your current. Turn the air control valve counterclockwise to increase the air mixture and clockwise to turn it off.

To minimize heat loss, close the air control valve when the spa is not in use.

6. Repeat same procedure with all pumps.

Each hydrotherapy jet in the spa can be adjusted for massage intensity and directional flow. Turn the outer jet dial counterclockwise to increase the water volume and clockwise to turn it off. Pivot the angle of a jet to achieve an optimal massage.

7. Your spa water will heat approximately 1° per hour, on average. Times may vary.
8. Adjust water chemistry according to the Water balancing instruction (next section).

Water Balancing

Once your spa reaches 95°F, use *Spa Test Strips* (not included) and add the necessary chemicals (not included) to stabilize your water chemistry. Turn Pump 1 on high speed before starting your tests to distribute chemicals evenly. Wait 5 minutes between measurements to allow added chemicals to mix thoroughly.

Important: Test the condition of your water in the following order:

1. **Total Alkalinity** (80-120 ppm) – Use our *Alkalinity Increaser* to raise total alkalinity and *Alkalinity Decreaser* to lower it. Low total alkalinity has little buffering capacity making the pH erratic. High total alkalinity has too much buffering capacity making the pH difficult to change.
2. **pH** (7.2-7.8) – Use *Spa Up* to raise the pH level and *Spa Down* to lower it.
 **Caution:** A pH lower than 7.2 can harm the metal surfaces of your spa and irritate your eyes and skin. A pH higher than 7.8 can create calcium deposits (scaling) on the shell and equipment.
3. **Hardness** (150-400 ppm) – Add *Increase Calcium* until the proper level is achieved. Unfortunately, there is no practical way to lower the native water hardness other than using a different source of water when filling your spa. Low hardness causes equipment corrosion and water foaming.
4. **Sanitizer** (3.0-5.0 ppm) – Use our *Deluxe Bromine Kit* to add Bromine until the proper level is achieved. Neglected spa water can breed bacteria and algae causing bather discomfort, skin rashes, and/or irritation.

Test	Range
Total Alkalinity	80-120 ppm
pH	7.2-7.8
Calcium Hardness	150-400 ppm
Sanitizer	3.0-5.0 ppm

Table 3 - Recommended Ranges for Balanced Water

Note: Perform water balancing weekly and whenever you change water (or when the spa is first filled) to ensure proper water condition.

Topside Controls & Operation



Figure 13- ML700 Top Side Control Panel

US/Canada spas equipped with controller PEL2P3S2 (wiring diagram, Figure 7)
Export spas equipped with controller PGL2P3P4 (wiring diagram, Figures 8A, 8B)

The topside control panel ML700 operates and programs your spa. Basic button functions are described next.

When your spa is first time actuated, it will go into Priming mode, indicated by “Pr”. The Priming mode will last for less than 6 minutes (press “Warm” or “Cool” button to skip Priming Mode. And then the spa will begin to heat and maintain the water temperature in the Standard mode.

Jets 1 Button

Press the “Jets 1” button once to turn pump 1 on or off, and to shift between low and high speeds. If left running, the low speed turns off after two hours and high speed turns off after 15 minutes.

Jets 2-3 Buttons

Press the “Jets 2, 3” buttons once to turn each of pumps 2,3 on or off and shift between low and high speeds. If left running, the low speed turns off after two hours and high speed turns off after 15 minutes.

Light Button

Press the “Light” button to turn the spa light system on and off. The LED light system is preprogrammed with an assortment of lighting effects. When you turn Light off and turn on again within five (5) seconds, it advances to the next effect. When you turn Light off for more than five (5) seconds, it remembers that last effect you selected. The next time you turn on the Light will display the same effect. The Light will automatically turn off after approximately four (4) hours.

Circulation Pump Operation

Your spa is equipped with a circulation pump. The circulation pump provides 24-hour continuous water circulation and filtration. The circulation pump turns over the entire spa water capacity at a minimum of one time every hour (depending on water capacity). It works like this: a dedicated, energy efficient circulation pump constantly draws water from the spa, runs it through the filter 1 and the heater (heating only when necessary), then back to the spa. The ozone output is on whenever the circulation pump is running. The Circulation pump will turn off for 30 minutes at a time when the water temperature reaches 3°F (1.5°C) above the set temperature (most likely this will happen in a very hot climate or during summer).

Heater Operation

Your spa is equipped with an electrical heater. By setting your thermostat to the desired temperature, your heater will automatically turn on and off as needed. The temperature set point (set temperature) can be adjusted from 70°F to 104°F/21°C-40°C. To raise the set temperature press the “Warm Arrow Up” button. To lower the set temperature, press the “Cool Arrow Down” button. The start up temperature is set at 100°F/37.5°C. The last measured temperature is constantly displayed on the LCD. In Economy mode the heater heats the spa water only during filter cycles. In sleep mode the heater heats the spa water to within 20°F (11°C) of set temperature only during filter cycles.

Filter Cycle Programming

Additional water circulation, filtration and sanitation (filter 2) added to spa system. Two speeds pump 1 (Low) running during pre-programmed filtration cycles.

At the start of each filter cycle the pump 1 (low) and, if equipped, pumps 2-3 (high) will run for 30 seconds to prevent the spa water from becoming stagnant in the plumbing and air lines and improve skimming action to remove debris and suspensions from the water surface.

Your spa came programmed from the factory with these defaults. The first filter cycle is automatically activated at 8 a.m. and operates the pump 1 until 10 a.m. The filter indicator icon on display will light when filter 1 cycle is running.

The second filter cycle is automatically activated at 8 p.m. and operates the pump 1 until 10 p.m.. The filter indicator icon will light when filter 2 cycle is running.

To program custom filter cycle setting, press “Time”+”Mode/Prog” button+”Mode/Prog”+”Mode/Prog” within 3 seconds. The Program, Filter 1, Filter 2, and Start Time icons will appear on the display. Press “Warm” or “Cool” button to choose the Filter 1 start time hour. Each press changes the start time by 5 minutes. Press ”Mode/Prog” button to enter minutes. Press “Mode/Prog” to see the Program, Filter 1, and End time icons. Adjust time as done above.

Press ”Mode/Prog” button to see the Program, Filter 2, and Start time icons. Proceeds as above. Press ”Mode/Prog” button to see the Program, Filter 2, and End time icons. Adjust time as previously stated.. Press “Mode/Prog” button again to enter the new filter time setting in system and display the current water temperature. Press “Time” button at any time during this programming sequence

to save the values entered up to that point and exit programming.

Ozone System

Your spa is equipped with ozone purification system. You will find that your spa water stays fresh and clear with significantly less chemical sanitizer usage. You will be able to go longer between complete spa draining. The ozone generator 1 operates in conjunction with the circulation pump and ozone generator 2 running with two speeds pump 1 at low speed in programming filtration cycles. Ozone generator 1 is on any time the circulation pump is running.

Freeze Protection

If the temperature sensor detects a temperature drop to 44°F (6.7°C) within the heater, then the pump automatically activates to provide freeze protection. The equipment stays on until four (4) minutes after the sensors detect that the spa water temperature has risen to 45°F (7.2°C) or higher. In colder climates, an optional additional freeze sensor may be added to protect against freeze condition that may not be sensed by the standard sensors. Auxiliary Freeze sensor protection acts similarly except with the temperature thresholds determined by the switch and without a four (4) minute delay in turnoff. See your dealer for details.

Locking the Panel

Press “Time”, “Jets 1” then “Warm Arrow Up” buttons within three (3) seconds. When locked, the “PL” indicator light will light. All buttons are frozen except the “Time” button. To unlock the panel, press “Time”, “Jets 1” then “Cool Arrow Down.”

Locking the Temperature Setting

Press “Warm Arrow Up” or “Cool Arrow Down” then “Time,” “Jets 1,” and “Warm Arrow Up” buttons within three (3) seconds to activate lock. When locked, the “TL” indicator light will light when the set temperature is locked. To unlock the set temperature, press “Warm Arrow Up” or “Cool Arrow Down” then “Time”, “Jets 1,” and “Cool Arrow Down.”

Spa control power limitations

The spa protected 60A GFCI (maximum spa load should not exceed 48A).

The spa control deactivate heater if any High speed pump is running (export spas) and more than one High speed pump (US/Canada spas).

The spa control allows only three High speed pumps running at same time.

Error Codes

MESSAGE	MEANING	ACTION REQUIRED
<i>(none)</i>	No message on display. Power has been cut off to hot tub.	The control panel is disabled until power returns. Hot tub settings are preserved.
OHH HH	The hot tub has shut down from high heat detection. One of the sensors detected 118°F (48°C) at the heater.	Do not enter the water. Remove the cover and allow the water to cool. Once cool, push any button. If the hot tub does not reset, turn off the GFCI and call service.
OHS OH	The hot tub has overheated and shut down. One of the sensors detected that the hot tub water is 110°F (43°C).	Do not enter the water. Remove the cover and allow the water to cool. At 107°F (42°C), the hot tub resets automatically. If the hot tub does not reset, turn off the GFCI and call service.
ICE IC	Potential freeze condition detected (Ice)	No action required. The pump will automatically operate regardless of the hot tub status.
SnA SA	Sensor A is not working correctly. Hot tub is shut down.	Check the sensor "A" plug connection to circuit board. The problem may appear temporarily in an overheat situation and disappear when the heater cools. If the problem persists, contact service.
SnB SB	Sensor B is not working correctly. Hot tub is shut down.	Check the sensor "B" plug connection to circuit board. The problem may appear temporarily in an overheat situation and disappear when the heater cools. If the problem persists, contact service.
SnS Sn	Sensors are out of balance.	If this alternates with the temperature, it may be temporary. If the display shows only this message (periodically blinking), the hot tub is shut down. If the problem persists, contact service.
HFL HL	A substantial difference between sensors was detected (possible flow problem).	Check water level in hot tub and add water if necessary. Be sure that slide-valves are open. Make sure the pump is primed and has power. If the problem persists, contact service.

MESSAGE	MEANING	ACTION REQUIRED
LF	<i>Low Flow</i> – persistent problem. Displays after the fifth occurrence of the "HL" message within 24 hours. Heater shuts down but other hot tub functions run normally.	Heating ability of the hot tub will not reset automatically; press any button to reset.
dr	Inadequate water, poor flow, or air bubbles detected in the heater. Hot tub is shut down for 15 minutes.	Check the water level and add water if necessary. Be sure that slide-valves are open. Make sure the pump is primed and has power. Press any button to reset (automatically reset within 15 minutes). If the problem persists, contact service.
drY dy	Inadequate water detected in heater. Displays on third occurrence of "dr" message. Hot tub is shut down.	Check water level in hot tub. Add water if necessary. Be sure that slide-valves are open. Make sure the pump is primed and has power. Press any button to reset.
Pr	When the hot tub is first activated, it goes into Priming mode.	The Priming mode runs for up to four minutes and then the hot tub begins to heat and maintain the water temperature in Standard mode.
-- F	Temperature unknown	After the pump has been running for two minutes, the temperature will be displayed.
-- C	Temperature unknown	After the pump runs for two minutes, the temperature displays
---	Temperature not current	The hot tub is in either Economy or Sleep modes and the pump has not run for a while. To view the current temperature, switch to Standard mode or operate Jets 1 for at least one minute.
SbY	Hot tub is in standby mode	Press any button except Jets 1 to leave Standby mode.
PHL(option)	pH is low	Add pH increaser (pH up)
PHH(option)	pH is high	Add pH decreaser (pH down)
SAL(option)	Sanitizer is low	Add sanitizer
SAH(option)	Sanitizer is high	Remove hot tub cover and allow sanitizer to evaporate
drn	Pump is on during Standby mode to assist in draining the water	Press Jets 1 to turn off pump once the water has drained out
rtC	Hardware failure	Contact customer service
PSt	Hardware failure	Contact customer service

MESSAGE	MEANING	ACTION REQUIRED
CrC	Firmware install problem	Contact customer service if this message appears on more than one power up
CFE	Configuration error. Hot tub cannot start up	Contact customer service
9FI	Could not trip GFCI	Contact customer service and do not use the hot tub.
StU	Pump appears to be stuck on	Contact customer service and do not use the hot tub
Hot	Pump was stuck on the last time it was powered on	Contact customer service and do not use the hot tub

Table 4-Error Codes

Message	Frequency	Action Required
rPH	7 days	Test and adjust pH chemical levels.
rSA	7 days	Test and adjust sanitizer chemical levels.
rCL	30 days	Remove, clean, and reinstall filter.
rt9	30 days	Test & reset GFCI breaker.
rdr	90 days	Drain and refill hot tub.
rCO	180 days	Clean and condition cover.
rtr	180 days	Clean and condition exterior surfaces.
rCH	365 days	Install new filter.
rCA	As needed	Install new Mineral cartridge.

Table 5- Reminder Messages for ML700 panel

Special Operating Instructions

Your spa equipped with different water features including waterfalls, water balls.

To activate any water feature installed on spa turn on pump 2 (typical) pressing the “Jets 2” button on top side panel. The two speed pump will start and move water through therapy jets and water features. If the water does not flow through the water features, turn “on-off” valves 1-4 located on spa lip and adjust water flow each feature as you desire. Be sure you adjust the water flow when pump running on highest speed to prevent water splashing.

For some spa models it can be pump 1 running the water features. Press “Jets1” button to activate the water features. Turn “on-off” valve and adjust water flow of each feature as you desire.

Optional MRD85i AM/FM with internal DMD Dock/Stereo Sirius Satellite Ready Marine stereo

MRD85i features DMD Dock, Bluetooth and is an AM/FM/Sirius Satellite Ready stereo with internal docking station for your digital music devices (DMD) like i-Pod, MP3 or Smartphone. Insert your digital music devices and play your music. MRD85i is full featured waterproof marine stereo, waterproof designed, engineered and optimized for spa use. With adjustable backlight display type with flip down face design. SD Card Reader available at the front. USB input available to play your music from a USB Flash drive. Additional AUX Input available at the back. Wireless Remote. Selectable EQ setup so you can select best audio setting for particular speakers. Bluetooth enable.

NOTE: For instructions on how to operate your AM/FM audio system, capabilities and features, see the manufacturer's Operational Manuals (provided).



Figure 14 – Optional MRD85i Stereo

Some spa models can be equipped with different type of Audio system. See audio system Operational Manual for details.

Spa Cover

Place the insulated cover on your spa. Keeping the cover in place anytime the spa is not in use reduces the heating time and minimizes operating costs. The time required for initial heat-up varies depending on the starting water temperature, ambient temperature, and the capacity of your spa.

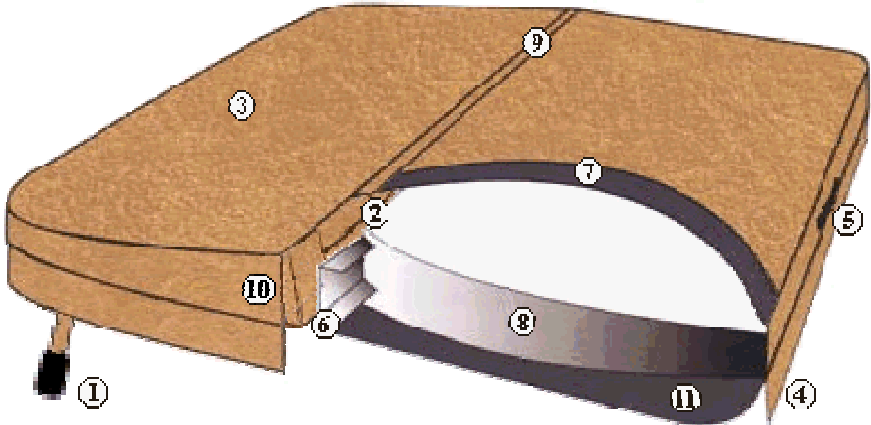

Figure 15 - Cover Callouts

- | | |
|--------------------------------|-------------------------------------|
| 1. Lock-down tab | 7. Heat-sealed insulation |
| 2. Double-stitched seams | 8. Chemical-resistant vapor barrier |
| 3. Marine-grade cover material | 9. Polystyrene seam stoppers |
| 4. Edge overlap material | 10. Reinforced edges |
| 5. Grip handle | 11. Breathable underside material |
| 6. Aluminum channel | |

Use the lock-down tabs to prevent access to the spa by children and to prevent the wind from lifting the cover off.



**Figure 16 -
Lockdown Tabs**

Sitting, standing, or allowing excessive weight such as snow to buildup on the cover will break the cover. Dragging it over rough surfaces will scuff or tear the fabric. Always lift by the handles or use the optional cover lift device.

Frequently Asked Questions

Who do I call for warranty information or service?

Call our customer care center between 8 a.m. and 5 p.m. EST Monday through Friday at 727.573.9611. Our representatives are eager to assist or you can get parts and information online at www.HotTubParts.com.

How do I bleed air from my system?

When draining and refilling your spa, the pump may become air locked. Air-locked pumps stop water from flowing in your spa and is easily resolved by bleeding off the trapped air. To do this:

1. Turn off the GFCI breaker
2. Open the access panel below the topside control panel
3. Loosen a heater union until you hear the trapped air escape
4. Once water drips out in a continuous stream, hand tighten the union until the water stops leaking
5. Loosen the discharge union on Pump (if equipped)
6. Once water drips out in a continuous stream, hand tighten the union until the water stops leaking
7. Turn on all pumps to make sure that there are no leaks
8. Put the access panels back on
9. Turn on the GFCI breaker

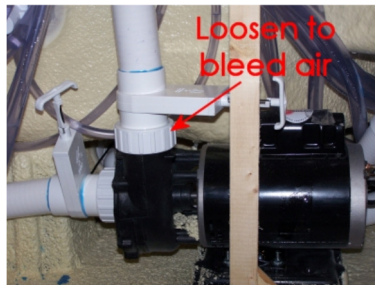

Figure 17 - Bleeding Air

What happens when my warranty expires?

Premium Leisure will continue to provide service for your spa after your warranty has expired via our customer care center at 727.573.9611.

Where can I get more Chemicals or other accessories?

Visit www.hottubparts.com or call 877.530.PARTS.

How should I clean my spa?

Use non-sudsing cleaners and non-oily polishes (Call). Our Citra Bright Spray Cleaner and our Tub Rub cleaning pad quickly removes scum lines and helps

restore your shell's original beauty. Rinse all filters, covers, pillows, and surfaces thoroughly with warm tap water. Our Filter Clean concentrated cleanser is a safe, effective way to clean and re-use your filters and our Jet Clean plumbing cleanser cleans the inside of all plumbing in your spa. Call 727.573.9611 to order these easy-to-use cleaning products.

How often should I drain my spa?

You should drain and refill your spa every 6-12 months depending on usage. Every other time you drain and refill, you should also replace the filters and wipe down the spa.

How do I adjust my spa jets?

Simply turn the jets counterclockwise to open and clockwise to close. Be careful not to overturn the jets, as damage can occur.

⚠ Caution: Do not turn off too many jets at the same time. This can create backflow and possible damage to your spa!

Are the spa jets removable? Interchangeable? Replaceable?

Most spa jets are made removable and adjustable for customized hydrotherapy. Do not attempt to remove the oval jets on the swim side of the unit.

Troubleshooting

If a problem arises, you can check this list for a quick solution. If this does not resolve your problem, please call our customer care center, at 727.573.9611. Additional information is also available at www.PremiumLeisure.com. You will need your serial number to access this site.

Important – Most electrical problems can be quickly resolved by resetting the GFCI breaker. Try this first before proceeding.

Spa Side Troubleshooting

PROBLEM	CAUSE	SOLUTION
Breaker trips	Wiring error	Load Neutral wire not connected to GFCI (connected to Neutral bus)
	Wrong GFCI	GFCI breaker is wrong size
	Ozonator wet	Remove tube from ozonator and allow 2 days to dry out

PROBLEM	CAUSE	SOLUTION
Foamy water	Soaps, skin oils, or undissolved sanitizer particles	Close the air control valves and allow filtration cycle to run Add defoamer Drain and clean your spa Clean or change filters Rinse all bathing suits before bathing
Leak	Loose connection Drain open	Check and hand-tighten unions at heater & pumps, or clamps on jets Close drain valve or replace cap
Light doesn't Work	LED burnt out Loose wire Loose plug	Replace bulb Check wiring harness to LED Reseat J20 plug on spa pack
Low/no jet pressure	Air lock Dirty filter Closed jets Closed valves ACV open Low water	Bleed air from the system (Figure 17) Check and clean or replace filter Open all jets by turning CCW Open all T-handle shutoff valves on heater and pumps Close air control valves Fill spa 1" above all jets
Moved my spa and now it doesn't work	Wiring error at GFCI No power to spa	Check Neutral wiring of GFCI (Figure 4) Reset circuit breakers on GFCI panel and main circuit breaker panel
Nothing works	Breaker has tripped Fuse blown	Check and reset breaker. If problem persists, check for loose electrical connections. Check for Neutral wiring error at GFCI. Check for blown fuses inside of spa pack.
Pump not running	No power to spa	Reset circuit breakers on GFCI panel and main circuit breaker panel
Water does not flow	Air lock Closed jets ACV open	Bleed air from the system (Figure 17) Open all jets by turning counterclockwise Close air control valves
Water too hot	High set temperature High ambient temperature	Turn down set temperature on topside control panel Remove the cover
Water will not heat	Thermostat is set too low Air open Dirty filter Blown fuse Slide valve closed Cover off Spa in Economy mode	Check and reset to desired temperature Close air control valve Check and clean filter Check and replace fuse Check and open all valves Put the cover back on Press the Standby button and take out of Economy

Maintenance and Care

Important – The warranty on your spa and equipment depends on proper sanitation (see page 22). In addition, the following maintenance procedures must be followed periodically.

Cabinets

Your cabinet is made from a polymer that combines the durability of plastic with the beauty of simulated wood. To clean the cabinet, a mild soap and water solution easily removes residue.

Spa Cover

The 5-inch thick tapered cover on your spa is made from a weatherproof marine-grade vinyl. It comes in two or three pieces, two that fold in half and one small section for the middle. See page 30 for cover installation information. Your cover will last much longer if you heed the following suggestions:

- 1) Don't drag the cover on the ground; wearing of the vinyl could easily develop into a tear.
- 2) The insulating foam in your cover is not designed to hold the weight of a person, or an animal.

Important – Cracked foam in the cover is not covered under warranty! Do not stand on it.

- 3) Occasionally clean the inside of your cover with our special All Purpose Cleaner rinsed with warm water. (Using soap or vinyl cleaners on the inside of your cover causes foamy water.) Call our order line at 727.573.9611 to order our All Purpose Cleaner.
- 4) Our special Vinyl Cover Cleaner applied to the outside of the cover and stitching once yearly will help prolong the appearance and life of your cover. Call our order line at 727.573.9611 to order our special Vinyl Cover Cleaner.
- 5) Do not lift the cover by the safety straps, they are made to secure the tub to the cabinet and may tear.

Draining and Refilling

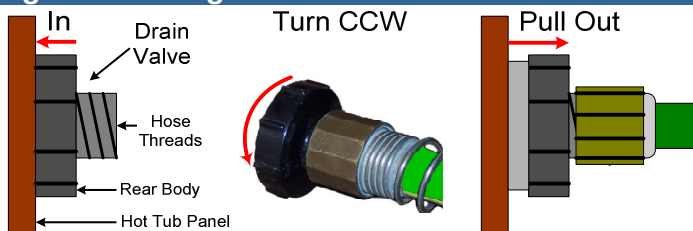

Figure 18 - Drain Operation

- 1) Turn off the GFCI breaker.
- 2) Remove spa cover and allow water to cool down.

- 3) Select a safe, suitable drainage area capable of safely assimilating approximately 400-600 gallons of water (1500-2300 liters) that may contain unsanitary contaminants and chemical residue that could cause harm to plants or grass.
- 4) Locate drain valve at base of the spa. Hold the rear body to prevent it from turning, then loosen and remove the front cap.
- 5) Attach a garden hose to the exposed threads and route the hose downhill to your drainage area.
- 6) Twist the drain fitting 1/3 turn counterclockwise to unlock the drain valve and pull it outward to open completely. The water will drain by gravitational flow.
- 7) After the spa drains, perform steps 3-5 in reverse order to close the drain prior to refilling spa.
- 8) Attach the garden hose to a thoroughly-flushed pre-filter (not included, rinsed of all residual sediment) and refill your spa through the filtration canister.
- 9) After refilling, turn on the GFCI breaker to the spa.

If the pump runs but no water flows, see Figure 17 to how bleed air from the water system.

Filters

The filters in your spa should be removed and cleaned every 1-2 weeks with our special Filter Clean concentrated cleanser and typically replaced every 4-6 months (depending upon use). You can clean your filters with the water pressure from the end of a garden hose then rinsed with warm water. This ensures that the water is being filtered properly.

DO NOT USE BLEACH. We recommend having replacement filters on hand that can be swapped between cleanings. Doing so enables you to quickly exchange the dirty filters with clean ones and immediately start your spa again. Call our order line at 727.573.9611 to order replacement filters and our special Filter Clean concentrated cleanser.

Spa Jets

Remove and clean the spa jets as needed using our special Jet Clean plumbing cleanser, water, and a cloth or soft-bristled brush. Call our order line at 727.573.9611 to order our special our Jet Clean plumbing cleanser.

Light

Drain the spa and clean the light lens as needed using an optical cloth and an eyewear cleaning product specifically designed not to scratch optical surfaces. If the back side of the lens is also dirty remove the rear panel, remove the light from the holder, and clean in this same manner.

Pillows

Remove and clean the headrest pillows as needed using our Citra Bright Spray Cleaner and our Tub Rub cleaning pad and rinsed thoroughly with warm water. Call our order line at 727.573.9611 to order our Citra Bright Spray Cleaner and our Tub Rub cleaning pad.

Sanitation

Sanitation level is influenced by two factors:

1. Filter Cycle (filtration) time
2. How much you use your spa each week

If your water chemistry and water clarity are all proper and your sanitation level is still too low/high, you can adjust the sanitation intensity up/down by adding more/less sanitizer a little at a time and testing the water again after two days.

Shutdown / Winterizing



Your Premium Leisure spa is designed to operate year round. If you plan to leave your spa unused for long periods of time in severely cold weather, you should winterize your spa to avoid accidental freezing due to a power or equipment failure.

We highly recommend that you have a spa professional winterize and restart your spa.

⚠ WARNING: Damage from improperly winterizing or restarting your spa is not covered under your warranty. You can call our customer care center, at 727.573.9611 for recommended service organizations to assist you in properly winterizing your spa.

Surface

The acrylic surface of your spa should be cleaned with our Citra Bright Spray Cleaner and our Tub Rub cleaning pad and thoroughly rinsed with warm (not cold) water before refilling. Call our order line at 727.573.9611 to order cleaners.

⚠ WARNING: NEVER use paint solvents, acids, acetone, benzene, lacquer thinner, toluene, xylene, or similar chemicals to clean your spa shell.

Water Management

Our chemical water purification system is a perfect match for your spa.

Depending on usage, the water in your spa should be changed every 3-4 months. Upon each change of water it is a good practice to wipe down the spa.

If your water quality seems improper, increasing the time the spa filters the water may clear up your problem.

Below are some answers to common water chemistry questions.

pH	It is common to have pH fluctuations after adding chemicals to your spa or after a party. Let your jets run and give your water time to stabilize. 9 times out of 10, your pH will come back into the 7.2-7.8 range on its own.
MILDEW on cover	Mildew may grow in the folds and seams of your cover and then drips into your spa water causing cloudiness and/or odor. Clean with our special Citra Bright Spray Cleaner and then rinse the inside of your cover with clean warm water.
Foamy water	Foam may result from soap residue on your skin and hair, or laundry detergent residue on clothing. Take a soapless shower and rinse all clothing in warm water prior to bathing.
CLEAR green or brown water	Your "source water" most likely has dissolved heavy metals. When this is the case, order our special Metal Gon metal remover. Using a pre-filter can remove these contaminants before they get into your spa.
CLOUDY green water	Algae can be resolved by adding a respected brand of algaecide.
CLOUDY white water	Although a normal condition immediately after filling that dissipates after time, with stabilized water this is a visual indication that the total alkalinity or pH or both are at improper levels. Test your water weekly and maintain proper water chemistry.
ODOR and/or CLOUDY water	If your water develops an odor and/or cloudiness, clean your cover and filters and try increasing the amount of time the spa filters per day by turning your filtration cycle time or duration up.
HEAVY use	After a period of heavy use, your spa may cloud. Shock your spa with 2 ounces of non-chlorine shock and wait 24-36 hours.

Specifications

PR982/ 1210PR

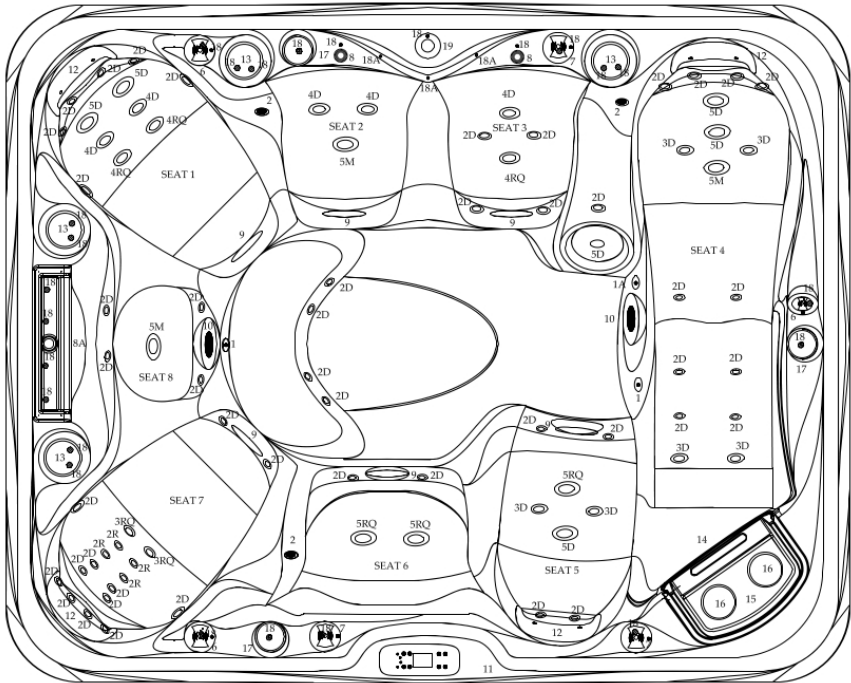

Spa Spec	
Spa Model	1210PR/PR982
Spa Dimension	91"x 114"x 38"
Number Of Seats	8
Water Jets	82
Water Capacity (USG/L)	575/2177
Dry Weight (LBS/KG)	1146/520
Filled Weight (LBS/KG)	5946/2697
Electrical Rating (VAC/AMP/HZ)	240/48/60
GFCI (AMP)	60

Call-Outs				
Label	Part#	Description	Qty.	Notes
1	73199W	Nozzle wall fitting (Gr)	2	
1A	7818	Wall fitting (Gr)	1	
2	29211-001-500, 29210-000-000 23422-000-010	2.25" PrLc Non Adj Jet, Leaf, SS/SII/IGG; 2" Cluster Jet Snap, White, THD-RB, Compensator Ring.	3	
2D	29527-011-500, 29222-200-300 23422-000-010	2.25" PrLc Jet Int(Leaf, Dir. (SS/SII/IGG/GG); 200s Jet body, 3/4SB x 3/8"SB, Compensator Ring.	47	
2R	29527-021-500, 29222-200-300, 23422-000-010,	2.25" PrLc Jet Int(Leaf, Roto (SS/SII/IGG/GG); 200s Jet body, 3/4SB x 3/8"SB, Compensator Ring.	4	
3D	29537-111-500, 29232-200-200, 23432-000-010	3.25" PrLc Jet Int(Leaf, Dir. (SS/SII/IGG/GG); 300s Jet body, 3/4SB x 3/8"SB, Compensator Ring.	6	
3RQ	29537-101-500, 29232-200-200, 23432-000-010	3.25" PrLc Jet Int(Leaf, 4-Roto (SS/SII/IGG/GG); 300s Jet body, 3/4SB x 3/8"SB, Compensator Ring.	2	
3R	29537-121-500, 29232-200-200, 23432-000-010	3.25" PrLc Jet Int(Leaf, Roto (SS/SII/IGG/GG); 300s Jet body, 3/4SB x 3/8"SB, Compensator Ring.	0	
4D	29547-111-500, 29242-200-200, 23442-000-010	4.25" PrLc Jet Int(Leaf, Dir. (SS/SII/IGG/GG); 400s Jet body, 3/4SB x 3/8"SB, Compensator Ring.	5	
4RQ	29547-101-500, 29242-200-200, 23442-000-010	4.25" PrLc Jet Int(Leaf, 4-Roto (SS/SII/IGG/GG); 400s Jet body, 3/4SB x 3/8"SB, Compensator Ring.	3	
4R	29547-121-500, 29242-200-200, 23442-000-010	4.25" PrLc Jet Int(Leaf, Roto (SS/SII/IGG/GG); 400s Jet body, 3/4SB x 3/8"SB, Compensator Ring.	0	
5D	29557-011-500, 29252-200-200, 23452-000-010	5.25" PrLc Jet Int(Leaf, Dir. (SS/SII/IGG/GG); 500s Jet body, 3/4SB x 3/8"SB, Compensator Ring.	6	
5RQ	29557-001-500, 29252-200-200, 23452-000-010	5.25" PrLc Jet Int(Leaf, 4-Roto (SS/SII/IGG/GG); 500s Jet body, 3/4SB x 3/8"SB, Compensator Ring.	3	
5R	29557-021-500, 29252-200-200, 23452-000-010	5.25" PrLc Jet Int(Leaf, Roto (SS/SII/IGG/GG); 500s Jet body, 3/4SB x 3/8"SB, Compensator Ring.	0	
5M	29557-041-500, 29252-200-200, 23452-000-010	5.25" PrLc Jet Int(Leaf, Mass. (SS/SII/IGG/GG); 500s Jet body, 3/4SB x 3/8"SB, Compensator Ring.	3	
6	25059-300-000,	1" Variable Air Control, Leaf, SII/IGG/Sil	3	
7	25056-310-000,	1" On-Off Control, Leaf, SII/IGG/Sil	3	
8	25289-001-500	2.25" LED Laminar jet, Leaf	2	
8A	675-5289L-DSG	18" LED Spillway waterfall	1	
9	640-3790SGAV	251GPM Super Hi-Flo 2.5" Suction (metal)	6	
10	1219S	Light Kit 5" ,SS	2	
11	50390-02	Topside panel Spa Touch	1	
12	3133	Small rounded Pillow	4	
13	675-2010L	Speaker Magna Tune pop-up rot, LED(Graphite)	4	
14	822817	Weir door(Gr/Silver)	1	
15	1238	Filter Lid(Gr)	1	
16	61368	Cartridge Filter	2	1-1/2"NPT
17	25241-507-800	LED Deco Cup Holder	3	
18	1310A, 1312A, 1318A,1315, 1317, 1338, 24243-307-000	LED contr-r, 6-LED spyder, 2-LED spyder, 9-LED light, Cables Assy, oval Spa Light	1+4+1+2+ 1+4	
18A	400372-N	Small lens with gasket, nut	3	
19	25290-000-020, 25290-009-010	Water ball Assy.	1+1	
N/A	7136, 6023, 310-0140	2 Speed Motor; 8' Cord ; Wet end 0140;	3	
N/A	7135, 6024, 310-0140	1 Speed Motor; 8' Cord ; Wet end 0140;	0	
N/A	6167, 6024, 310-0800	Circ. pump motor; 8' Cord ; Wet end 0800;	1	
N/A	56721	BP2000G1	1	
N/A	5071, 7399	Ozonator w/ Cord, Injector	2+2	
N/A	7303, 7876B	Premium Owner's Manual, INSERT	1	
N/A	7508(AH.G)	Spa cover 114.5"x95.5"	1	
N/A	59019-01, 25717, CS-P80, 1142	Balboa Bluetooth Amp, Adapter cable, Passive Subwoofer w harness, power supply 100-240vac	1	
N/A	50350-03	Wi-Fi Module	1	

PR982-EX/1210PR-EX Export

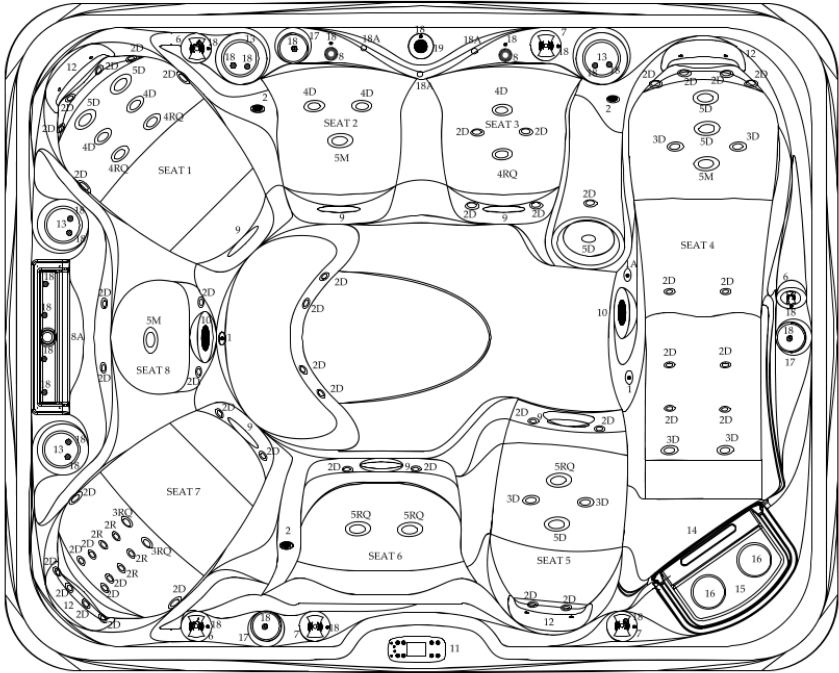

Spa Spec	
Spa Model	1210PR-EX/PR982-EX
Spa Dimension	91"x 114"x 38"
Number Of Seats	8
Water Jets	82
Water Capacity (USG/L)	575/2177
Dry Weight (LBS/KG)	1146/520
Filled Weight (LBS/KG)	5946/2697
Electrical Rating (VAC/AMP/HZ)	220-240/3x16/50
RCD(AMP)	IEE REQ.

Call-Outs				
Label	Part#	Description	Qty.	Notes
1	73199W	Nozzle wall fitting (Gr)	2	
1A	7818	Wall fitting (Gr)	1	
2	29211-001-500, 29210-200-000 23422-000-010	2.25" PrLc Non Adj Jet, Leaf,SS/Sil/GG; 2" Cluster Jet Snap, White-THD-RB, Compensator Ring,	3	
2D	29527-011-500, 29222-200-300 23422-000-010	2.25" PrLc Jet Int(Leaf, Dir. (SS/Sil/GG/GG); 200s Jet body, 3/4SB x 3/8"SB, Compensator Ring,	47	
2R	29527-021-500, 29222-200-300, 23422-000-010,	2.25" PrLc Jet Int(Leaf, Rolo (SS/Sil/GG/GG); 200s Jet body, 3/4SB x 3/8"SB, Compensator Ring,	4	
3D	29537-111-500, 29232-200-200, 23432-000-010	3.25" PrLc Jet Int(Leaf, Dir. (SS/Sil/GG/GG); 300s Jet body, 3/4SB x 3/8"SB, Compensator Ring,	6	
3RQ	29537-101-500, 29232-200-200, 23432-000-010	3.25" PrLc Jet Int(Leaf, 4-Rolo (SS/Sil/GG/GG); 300s Jet body, 3/4SB x 3/8"SB, Compensator Ring,	2	
3R	29537-121-500, 29232-200-200, 23432-000-010	3.25" PrLc Jet Int(Leaf, Rolo (SS/Sil/GG/GG); 300s Jet body, 3/4SB x 3/8"SB, Compensator Ring,	0	
4D	29547-111-500, 29242-200-200, 23442-000-010	4.25" PrLc Jet Int(Leaf, Dir. (SS/Sil/GG/GG); 400s Jet body, 3/4SB x 3/8"SB, Compensator Ring,	5	
4RQ	29547-101-500, 29242-200-200, 23442-000-010	4.25" PrLc Jet Int(Leaf, 4-Rolo (SS/Sil/GG/GG); 400s Jet body, 3/4SB x 3/8"SB, Compensator Ring,	3	
4R	29547-121-500, 29242-200-200, 23442-000-010	4.25" PrLc Jet Int(Leaf, Rolo (SS/Sil/GG/GG); 400s Jet body, 3/4SB x 3/8"SB, Compensator Ring,	0	
5D	29557-011-500, 29252-200-200, 23452-000-010	5.25" PrLc Jet Int(Leaf, Dir. (SS/Sil/GG/GG); 500s Jet body, 3/4SB x 3/8"SB, Compensator Ring,	6	
5RQ	29557-001-500, 29252-200-200, 23452-000-010	5.25" PrLc Jet Int(Leaf, 4-Rolo (SS/Sil/GG/GG); 500s Jet body, 3/4SB x 3/8"SB, Compensator Ring,	3	
5M	29557-041-500, 29252-200-200, 23452-000-010	5.25" PrLc Jet Int(Leaf, Mass. (SS/Sil/GG/GG); 500s Jet body, 3/4SB x 3/8"SB, Compensator Ring,	3	
6	25059-300-000,	1" Variable Air Control, Leaf, Sil/GG/Sil	3	
7	25056-310-000,	1" On-Off Control, Leaf, Sil/GG/Sil	3	
8	25269-001-500	2.25" LED Laminar Jet Leaf	2	
8A	675-5289L-DSG	18" LED Spillway waterfall	1	
9	640-3790SGAV	251GPM Super Hi-Flo 2.5" Suction (metal)	6	
10	1219S	Light Kit 5" SS	2	
11	50390-02	Topside panel Spa Touch	1	
12	3133	Small rounded Pillow	4	
13	675-2010L	Speaker Magna Tune pop-up rot. LED(Graphite)	4	
14	822817	Weir door(Gr/Silver)	1	
15	1238	Filter Lid(Gr)	1	
16	61368	Cartridge Filter	1	1-1/2"NPT
17	630-0038	Cup Holder LED	3	
18	1310A, 1312A, 1318A, 1315, 1317, 1338, 25243-307-000	LED contr-., 6-LED spyder, 2-LED spyder, 9-LED light, Cables Assy, Oval spa light	1+4+1+2+ 1+1+4	
18A	400372-N	Small lens with gasket, nut	3	
19	25290-000-020, 25290-009-010	Water ball Assy.	1+1	
N/A	7136, 6023, 310-0140	2 Speed Motor; 8' Cord ; Wet end 0140;	3	
N/A	7135, 6024, 310-0140	1 Speed Motor; 8' Cord ; Wet end 0140;	0	
N/A	6167, 6024, 310-0800	Circ. pump motor; 8' Cord ; Wet end 0800;	1	
N/A	56723	BP2100G1	1	
N/A	5071, 7399	Ozonator w/ Cord, Injector	2+2	
N/A	7303, 7876B	Premium Owner's Manual, insert	1	
N/A	7508(AH,G)	Spa cover 114.5"x95.5"	1	
N/A	59019-01, 25717, CS-P80, 1142	Balboa Bluetooth Amp, Adapter cable, Passive Subwoofer w.harness, power supply 100-240vac	1	
N/A	50350-03	Wi-Fi Module	1	

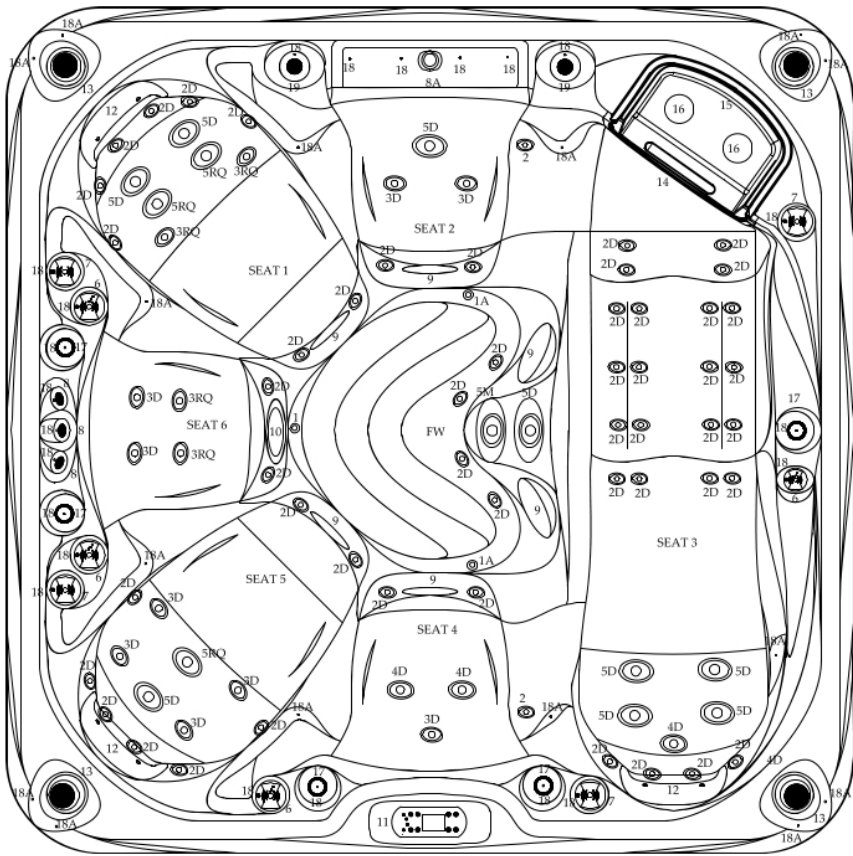

Spa Spec	
Spa Model	1215PR/PR881
Spa Dimension	91"x 91"x 38"
Number Of Seats	6
Water Jets	81
Water Capacity (USG/L)	415/1572
Dry Weight (LBS/KG)	926/420
Filled Weight (LBS/KG)	4392/1992
Electrical Rating (VAC/AMP/HZ)	240/48/60
GFCI (AMP)	60

Call-Outs				
Label	Part#	Description	Qty.	Notes
1	73199W	Nozzle wall fitting (Gr)	1	
1A	7818	Wall fitting (Gr)	2	
2	29211-001-500, 29210-000-000 23422-000-010	2.25" PrLc Non Adj Jet, Leaf, SS/Sil/GG; 2" Cluster Jet Snap, White, THD-RB, Compensator Ring,	2	
2D	29527-011-500, 29222-200-300 23422-000-010	2.25" PrLc Jet Int(Leaf, Dir. (SS/Sil/GG/GG); 200s Jet body, 3/4SB x 3/8"SB, Compensator Ring,	50	
2R	29527-021-500, 29222-200-300, 23422-000-010,	2.25" PrLc Jet Int(Leaf, Roto (SS/Sil/GG/GG); 200s Jet body, 3/4SB x 3/8"SB, Compensator Ring,	0	
3D	29537-111-500, 29232-200-200, 23432-000-010	3.25" PrLc Jet Int(Leaf, Dir. (SS/Sil/GG/GG); 300s Jet body, 3/4SB x 3/8"SB, Compensator Ring	9	
3RQ	29537-101-500, 29232-200-200, 23432-000-010	3.25" PrLc Jet Int(Leaf, 4-Roto (SS/Sil/GG/GG); 300s Jet body, 3/4SB x 3/8"SB, Compensator Ring,	4	
3R	29537-121-500, 29232-200-200, 23432-000-010	3.25" PrLc Jet Int(Leaf, Roto (SS/Sil/GG/GG); 300s Jet body, 3/4SB x 3/8"SB, Compensator Ring,	0	
4D	29547-111-500, 29242-200-200, 23442-000-010	4.25" PrLc Jet Int(Leaf, Dir. (SS/Sil/GG/GG); 400s Jet body, 3/4SB x 3/8"SB, Compensator Ring	3	
4RQ	29547-101-500, 29242-200-200, 23442-000-010	4.25" PrLc Jet Int(Leaf, 4-Roto (SS/Sil/GG/GG); 400s Jet body, 3/4SB x 3/8"SB, Compensator Ring,	0	
4R	29547-121-500, 29242-200-200, 23442-000-010	4.25" PrLc Jet Int(Leaf, Roto (SS/Sil/GG/GG); 400s Jet body, 3/4SB x 3/8"SB, Compensator Ring,	0	
5D	29557-011-500, 29252-200-200, 23452-000-010	5.25" PrLc Jet Int(Leaf, Dir. (SS/Sil/GG/GG); 500s Jet body, 3/4SB x 3/8"SB, Compensator Ring,	9	
5RQ	29557-001-500, 29252-200-200, 23452-000-010	5.25" PrLc Jet Int(Leaf, 4-Roto (SS/Sil/GG/GG); 500s Jet body, 3/4SB x 3/8"SB, Compensator Ring,	3	
5R	29557-021-500, 29252-200-200, 23452-000-010	5.25" PrLc Jet Int(Leaf, Roto (SS/Sil/GG/GG); 500s Jet body, 3/4SB x 3/8"SB, Compensator Ring,	0	
5M	29557-041-500, 29252-200-200, 23452-000-010	5.25" PrLc Jet Int(Leaf, Mass. (SS/Sil/GG/GG); 500s Jet body, 3/4SB x 3/8"SB, Compensator Ring,	1	
6	25059-300-000,	1" Variable Air Control, Leaf, Sil/GG/Sil	4	
7	25056-310-000,	1" On-Off Control, Leaf, Sil/GG/Sil	4	
8	25269-001-500	2.25" LED Laminar jet, Leaf	3	
8A	675-5289L-DSG	18" LED Spillway waterfall	1	
9	640-3790SGAV	251GPM Super Hi-Flo 2.5" Suction (metal)	6	
10	1219S	Light Kit 5", SS	1	
11	50390-02	Topside panel Spa Touch	1	
12	3133	Small rounded Pillow	4	
13	AQ-SPK3.0-4S	Speaker AQ-SPK	4	
14	822817	Weir door(Gr/Silver)	1	
15	1238	Filter Lid(Gr)	1	
16	61368	Cartridge Filter	2	
17	25241-507-800	LED Deco Cup Holder	5	
18	1310A 1312A, 1318A,1315, 1317, 1338, 25243-307-000	LED contr-r, 6-LED spyder, 2-LED spyder, 9-LED light, Cables Assy, oval Spa Light	1+4+1+2+ 1+1+4	
19	25290-000-020, 25290-009-010	Water ball Assy.	2+2	
N/A	7136, 6023, 310-0140	2 Speed Motor; 8" Cord ; Wet end 0140;	3	
N/A	7135, 6024, 310-0140	1 Speed Motor; 8" Cord ; Wet end 0140;	0	
N/A	6167, 6024, 310-0800	Circ. pump motor; 8" Cord ; Wet end 0800.	1	
N/A	56721	Balboa Pack BP2000G1	1	
N/A	5071, 7399	Ozonator w/ Cord, Injector	2+2	
N/A	7303, 7876B	Premium Owner's Manual, insert	1	
N/A	XXXX(AH,G)	Spa cover 92"x 92"	1	
N/A	59019-01, 25717, CS-P80, 1142	Balboa Bluetooth Amp., Adapter cable, Passive Subwoofer w. harness, power supply 100-240vac	1	
N/A	50350-03	Wi-Fi module	1	

PR881-EX/1215PR-EX Export

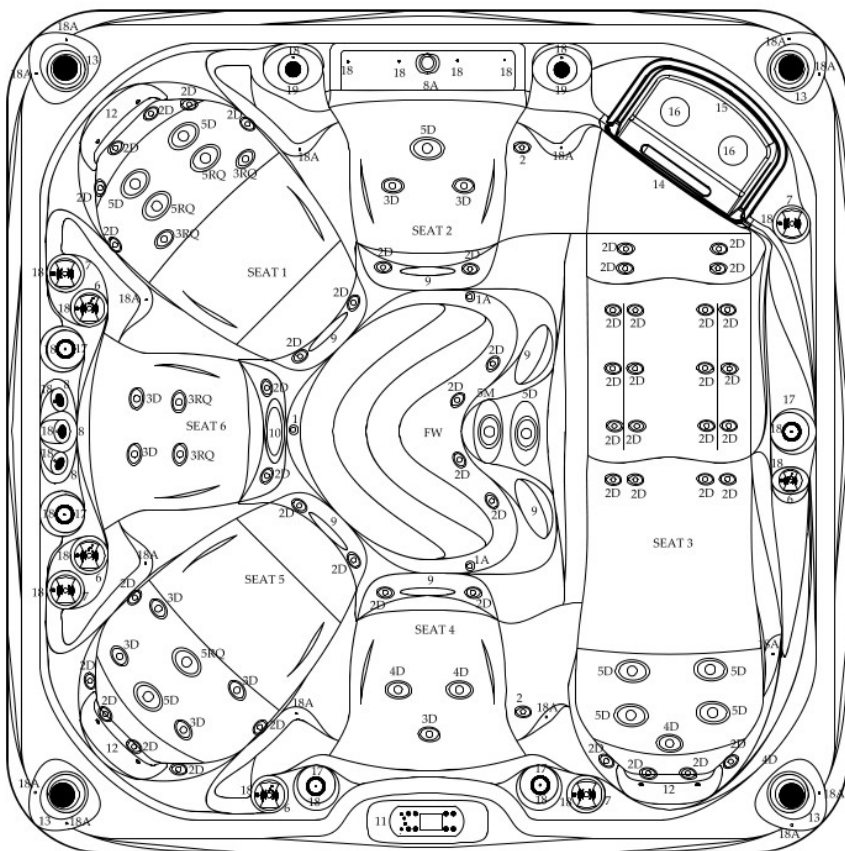

Spa Spec	
Spa Model	1215PR-EX/PR881-EX
Spa Dimension	91" x 91" x 38"
Number Of Seats	6
Water Jets	81
Water Capacity (USG/L)	415/1572
Dry Weight (LBS/KG)	928/420
Filled Weight (LBS/KG)	4392/1992
Electrical Rating (VAC/AMP/HZ)	220-240/3x16/50
RCD (AMP)	IEE REQ.

Call-Outs				
Label	Part#	Description	Qty.	Notes
1	73199W	Nozzle wall fitting (Gr)	1	
1A	7818	Wall fitting (Gr)	2	
2	29211-001-500, 29210-000-000 23422-000-010	2.25" PrLc Non Adj Jet, Leaf, SS/Sil/IGG; 2" Cluster Jet Snap, White, THD-RB, Compensator Ring,	2	
2D	29527-011-500, 29222-200-300 23422-000-010	2.25" PrLc Jet Int(Leaf, Dir. (SS/Sil/IGG/GG); 200s Jet body, 3/4SB x 3/8"SB, Compensator Ring,	50	
2R	29527-021-500, 29222-200-300, 23422-000-010,	2.25" PrLc Jet Int(Leaf, Roto (SS/Sil/IGG/GG); 200s Jet body, 3/4SB x 3/8"SB, Compensator Ring,	0	
3D	29537-111-500, 29232-200-200, 23432-000-010	3.25" PrLc Jet Int(Leaf, Dir. (SS/Sil/IGG/GG); 300s Jet body, 3/4SB x 3/8"SB, Compensator Ring,	9	
3RQ	29537-101-500, 29232-200-200, 23432-000-010	3.25" PrLc Jet Int(Leaf, 4-Roto (SS/Sil/IGG/GG); 300s Jet body, 3/4SB x 3/8"SB, Compensator Ring,	4	
3R	29537-121-500, 29232-200-200, 23432-000-010	3.25" PrLc Jet Int(Leaf, Roto (SS/Sil/IGG/GG); 300s Jet body, 3/4SB x 3/8"SB, Compensator Ring,	0	
4D	29547-111-500, 29242-200-200, 23442-000-010	4.25" PrLc Jet Int(Leaf, Dir. (SS/Sil/IGG/GG); 400s Jet body, 3/4SB x 3/8"SB, Compensator Ring,	3	
4RQ	29547-101-500, 29242-200-200, 23442-000-010	4.25" PrLc Jet Int(Leaf, 4-Roto (SS/Sil/IGG/GG); 400s Jet body, 3/4SB x 3/8"SB, Compensator Ring,	0	
4R	29547-121-500, 29242-200-200, 23442-000-010	4.25" PrLc Jet Int(Leaf, Roto (SS/Sil/IGG/GG); 400s Jet body, 3/4SB x 3/8"SB, Compensator Ring,	0	
5D	29557-011-500, 29252-200-200, 23452-000-010	5.25" PrLc Jet Int(Leaf, Dir. (SS/Sil/IGG/GG); 500s Jet body, 3/4SB x 3/8"SB, Compensator Ring,	9	
5RQ	29557-001-500, 29252-200-200, 23452-000-010	5.25" PrLc Jet Int(Leaf, 4-Roto (SS/Sil/IGG/GG); 500s Jet body, 3/4SB x 3/8"SB, Compensator Ring,	3	
5R	29557-021-500, 29252-200-200, 23452-000-010	5.25" PrLc Jet Int(Leaf, Roto (SS/Sil/IGG/GG); 500s Jet body, 3/4SB x 3/8"SB, Compensator Ring,	0	
5M	29557-041-500, 29252-200-200, 23452-000-010	5.25" PrLc Jet Int(Leaf, Mass. (SS/Sil/IGG/GG); 500s Jet body, 3/4SB x 3/8"SB, Compensator Ring,	1	
6	25059-300-000,	1" Variable Air Control, Leaf, Sil/IGG/Sil	4	
7	25056-310-000,	1" On-Off Control, Leaf, Sil/IGG/Sil	4	
8	25269-001-500	2.25" LED Laminar jet, Leaf	3	
8A	675-5289L-DSG	18" LED Spillway waterfall	1	
9	640-3790SGAV	251GPM Super Hi-Flo 2.5" Suction (metal)	6	
10	1219S	Light Kit 5" ,SS	1	
11	50390-02	Topside panel Spa Touch	1	
12	3133	Small rounded Pillow	4	
13	AQ-SPK3.0-4S	Speaker AQ-SPK	4	
14	822817	Weir door(Gr/Silver)	1	
15	1238	Filter Lid(Gr)	1	
16	61368	Cartridge Filter	2	
17	25241-507-800	LED Deco Cup Holder	5	
18	1310A, 1312A, 1318A, 1315, 1317, 1338, 25243-307-000	LED contr-r, 6-LED spyder, 2-LED spyder, 9-LED light, Cables Assy, oval Spa Light	1+4+1+2+ 1+1+4	
19	25290-000-020, 25290-009-010	Water ball Assy.	2+2	
N/A	7789, 6023, 310-0180	2 Speed Motor; 8' Cord ; Wet end 0180;	3	
N/A	7788, 6024, 310-0140	1 Speed Motor; 8' Cord ; Wet end 0180;	0	
N/A	7794, 6024, 310-0800	Circ. pump motor; 8' Cord ; Wet end 0800;	1	
N/A	56723	Balboa Pack BP2100G1	1	
N/A	5071, 7399	Ozonator w/ Cord, injector	2+2	
N/A	7303, 7876B	Premium Owner's Manual, insert	1	
N/A	XXXX(AH,G)	Spa cover 92"x 92"	1	
N/A	59019-01, 25717, CS-P80, 1142	Balboa Bluetooth Amp., Adapter cable, Passive Subwoofer w. harness, power supply 100-240vac	1	
N/A	50350-03	Wi-Fi module	1	

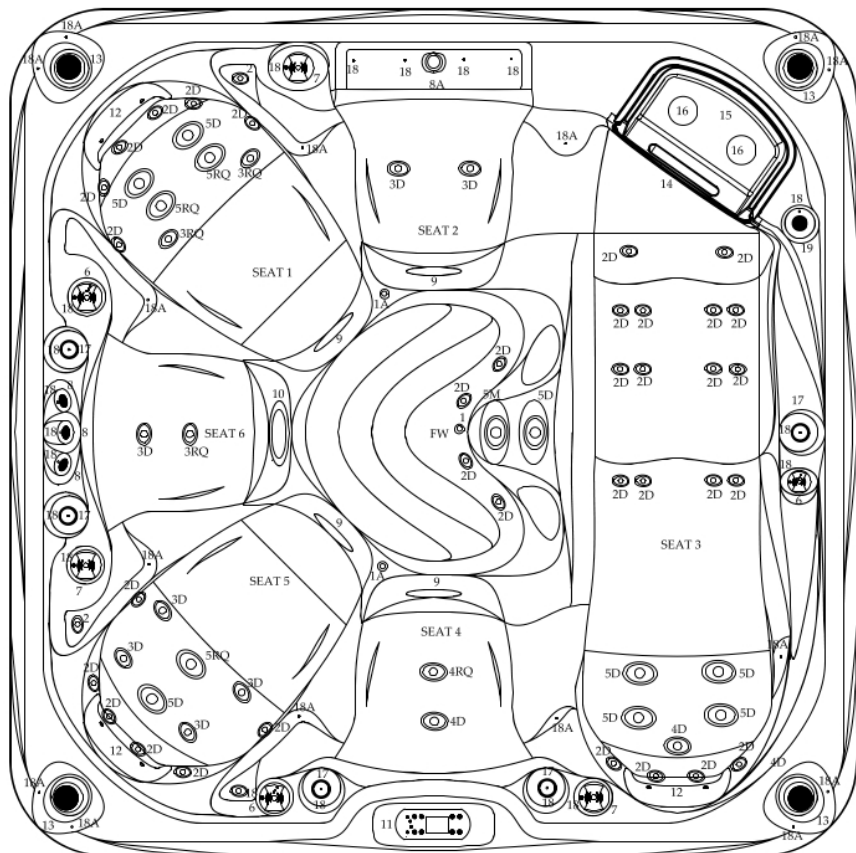

Spa Spec

Spa Model	1216PR/PR761
Spa Dimension	84"x 84"x 38"
Number Of Seats	6
Water Jets	61
Water Capacity (USG/L)	345/1300
Dry Weight (LBS/KG)	840/380
Filled Weight (LBS/KG)	3703/1680
Electrical Rating (VAC/AMP/HZ)	240/48/60
GFCI (AMP)	60

Call-Outs				
Label	Part#	Description	Qty.	Notes
1	73199W	Nozzle wall fitting (Gr)	1	
1A	7818	Wall fitting (Gr)	2	
2	29211-001-500, 29210-000-000 23422-000-010	2.25" PrLc Non Adj Jet, Leaf, SS/Sil/GG; 2" Cluster Jet Snap, White, THD-RB, Compensator Ring,	2	
2D	29527-011-500, 29222-200-300 23422-000-010	2.25" PrLc Jet Int(Leaf, Dir. (SS/Sil/GG/GG); 200s Jet body, 3/4SB x 3/8"SB, Compensator Ring,	34	
2R	29527-021-500, 29222-200-300, 23422-000-010,	2.25" PrLc Jet Int(Leaf, Roto (SS/Sil/GG/GG); 200s Jet body, 3/4SB x 3/8"SB, Compensator Ring,	0	
3D	29537-111-500, 29232-200-200, 23432-000-010	3.25" PrLc Jet Int(Leaf, Dir. (SS/Sil/GG/GG); 300s Jet body, 3/4SB x 3/8"SB, Compensator Ring,	7	
3RQ	29537-101-500, 29232-200-200, 23432-000-010	3.25" PrLc Jet Int(Leaf, 4-Roto (SS/Sil/GG/GG); 300s Jet body, 3/4SB x 3/8"SB, Compensator Ring,	3	
3R	29537-121-500, 29232-200-200, 23432-000-010	3.25" PrLc Jet Int(Leaf, Roto (SS/Sil/GG/GG); 300s Jet body, 3/4SB x 3/8"SB, Compensator Ring,	0	
4D	29547-111-500, 29242-200-200, 23442-000-010	4.25" PrLc Jet Int(Leaf, Dir. (SS/Sil/GG/GG); 400s Jet body, 3/4SB x 3/8"SB, Compensator Ring,	2	
4RQ	29547-101-500, 29242-200-200, 23442-000-010	4.25" PrLc Jet Int(Leaf, 4-Roto (SS/Sil/GG/GG); 400s Jet body, 3/4SB x 3/8"SB, Compensator Ring,	1	
4R	29547-121-500, 29242-200-200, 23442-000-010	4.25" PrLc Jet Int(Leaf, Roto (SS/Sil/GG/GG); 400s Jet body, 3/4SB x 3/8"SB, Compensator Ring,	0	
5D	29557-011-500, 29252-200-200, 23452-000-010	5.25" PrLc Jet Int(Leaf, Dir. (SS/Sil/GG/GG); 500s Jet body, 3/4SB x 3/8"SB, Compensator Ring,	8	
5RQ	29557-001-500, 29252-200-200, 23452-000-010	5.25" PrLc Jet Int(Leaf, 4-Roto (SS/Sil/GG/GG); 500s Jet body, 3/4SB x 3/8"SB, Compensator Ring,	3	
5R	29557-021-500, 29252-200-200, 23452-000-010	5.25" PrLc Jet Int(Leaf, Roto (SS/Sil/GG/GG); 500s Jet body, 3/4SB x 3/8"SB, Compensator Ring,	0	
5M	29557-041-500, 29252-200-200, 23452-000-010	5.25" PrLc Jet Int(Leaf, Mass. (SS/Sil/GG/GG); 500s Jet body, 3/4SB x 3/8"SB, Compensator Ring,	1	
6	25059-300-000,	1" Variable Air Control, Leaf, Sil/GG/Sil	3	
7	25056-310-000,	1" On-Off Control, Leaf, Sil/GG/Sil	3	
8	25269-001-500	2.25" LED Laminar jet, Leaf	3	
8A	675-5289L-DSG	18" LED Spillway waterfall	1	
9	640-3790SGA V	251GPM Super Hi-Flo 2.5" Suction (metal)	4	
10	1219S	Light Kit 5",SS	1	
11	50390-02	Topside panel SPA TOUCH	1	
12	3133	Small rounded Pillow	3	
13	AQ-SPK3.0-4S	Speaker AQ-SPK	4	
14	822817	Weir door(Gr/Silver)	1	
15	1238	Filter Lid(Gr)	1	
16	61368	Cartridge Filter	2	
17	25241-507-800	LED Deco Cup Holder	5	
18	1310A, 1312A, 1318A, 1315, 1317, 1338, 25243-307-000	LED contr-r, 6-LED spyder, 2-LED spyder, 9-LED light, Cables Assy, oval Spa Light	1+7+1+2+ 1+1+4	
19	25290-000-020, 25290-009-010	Water ball Assy,	1+1	
N/A	7136, 6023, 310-0140	2 Speed Motor; 8' Cord ; Wet end 0140;	2	
N/A	7135, 6024, 310-0140	1 Speed Motor; 8' Cord ; Wet end 0140;	0	
N/A	6167, 6024, 310-0800	Circ. pump motor; 8' Cord ; Wet end 0800;	1	
N/A	56721	Balboa Pack BP2000G1	1	
N/A	5071, 7399	Ozonator w/ Cord, Injector	2+2	
N/A	7303, 7876B	Premium Owner's Manual, insert	1	
N/A	XXXX(AH,G)	Spa cover 85"x85"	1	
N/A	59019-01, 25717, CS-P80, 1142	Balboa Bluetooth Amp, Adapter cable, Passive SUB w. harness, power supply 100-230/12vdc	1	
N/A	50350-03	Wi-Fi module	1	

PR761-EX/1216PR-EX Export

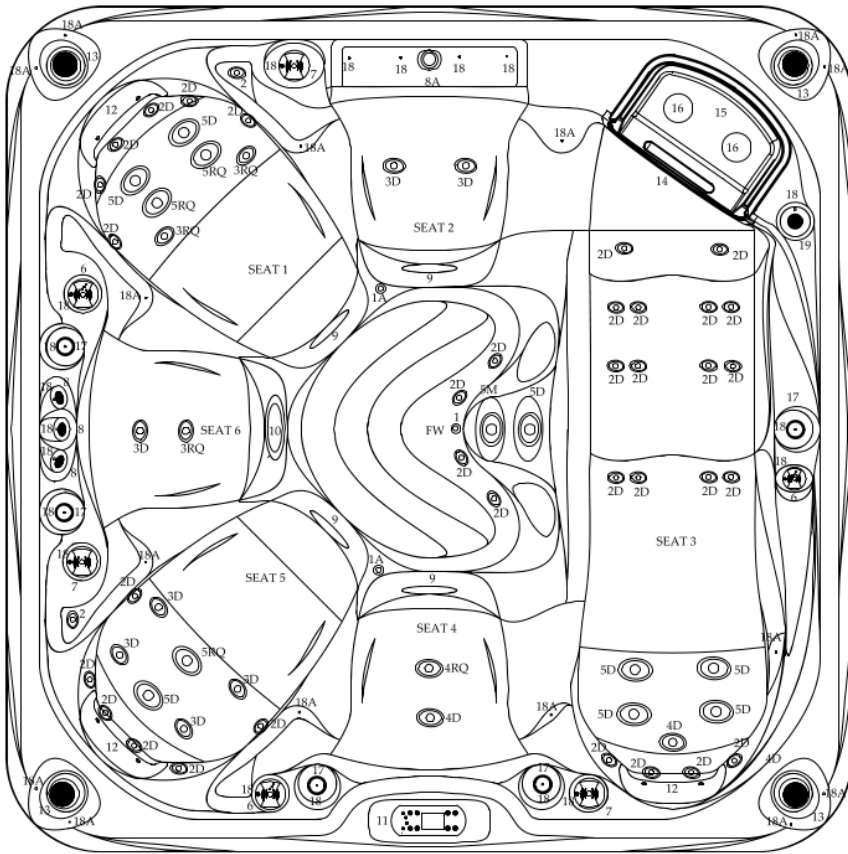

Spa Spec	
Spa Model	1216PR-EX/PR761-EX
Spa Dimension	84"x 84"x 38"
Number Of Seats	6
Water Jets	61
Water Capacity (USG/L)	345/1300
Dry Weight (LBS/KG)	840/380
Filled Weight (LBS/KG)	3703/1680
Electrical Rating (VAC/AMP/HZ)	220-240/3x16/50
RCD (AMP)	IEE REQ.

Call-Outs				
Label	Part#	Description	Qty.	Notes
1	73199W	Nozzle wall fitting (Gr)	1	
1A	7818	Wall fitting (Gr)	2	
2	29211-001-500, 29210-000-000 23422-000-010	2.25" PrLc Non Adj Jet, Leaf, SS/Sil/IGG; 2" Cluster Jet Snap, White, THD-RB, Compensator Ring,	2	
2D	29527-011-500, 29222-200-300 23422-000-010	2.25" PrLc Jet Int/Leaf, Dir. (SS/Sil/IGG/GG); 200s Jet body, 3/4SB x 3/8"SB, Compensator Ring,	34	
2R	29527-021-500, 29222-200-300, 23422-000-010	2.25" PrLc Jet Int/Leaf, Roto (SS/Sil/IGG/GG); 200s Jet body, 3/4SB x 3/8"SB, Compensator Ring,	0	
3D	29537-111-500, 29232-200-200, 23432-000-010	3.25" PrLc Jet Int/Leaf, Dir. (SS/Sil/IGG/GG); 300s Jet body, 3/4SB x 3/8"SB, Compensator Ring,	7	
3RQ	29537-101-500, 29232-200-200, 23432-000-010	3.25" PrLc Jet Int/Leaf, 4-Roto (SS/Sil/IGG/GG); 300s Jet body, 3/4SB x 3/8"SB, Compensator Ring,	3	
3R	29537-121-500, 29232-200-200, 23432-000-010	3.25" PrLc Jet Int/Leaf, Roto (SS/Sil/IGG/GG); 300s Jet body, 3/4SB x 3/8"SB, Compensator Ring,	0	
4D	29547-111-500, 29242-200-200, 23442-000-010	4.25" PrLc Jet Int/Leaf, Dir. (SS/Sil/IGG/GG); 400s Jet body, 3/4SB x 3/8"SB, Compensator Ring,	2	
4RQ	29547-101-500, 29242-200-200, 23442-000-010	4.25" PrLc Jet Int/Leaf, 4-Roto (SS/Sil/IGG/GG); 400s Jet body, 3/4SB x 3/8"SB, Compensator Ring,	1	
4R	29547-121-500, 29242-200-200, 23442-000-010	4.25" PrLc Jet Int/Leaf, Roto (SS/Sil/IGG/GG); 400s Jet body, 3/4SB x 3/8"SB, Compensator Ring,	0	
5D	29557-011-500, 29252-200-200, 23452-000-010	5.25" PrLc Jet Int/Leaf, Dir. (SS/Sil/IGG/GG); 500s Jet body, 3/4SB x 3/8"SB, Compensator Ring,	8	
5RQ	29557-001-500, 29252-200-200, 23452-000-010	5.25" PrLc Jet Int/Leaf, 4-Roto (SS/Sil/IGG/GG); 500s Jet body, 3/4SB x 3/8"SB, Compensator Ring,	3	
5R	29557-021-500, 29252-200-200, 23452-000-010	5.25" PrLc Jet Int/Leaf, Roto (SS/Sil/IGG/GG); 500s Jet body, 3/4SB x 3/8"SB, Compensator Ring,	0	
5M	29557-041-500, 29252-200-200, 23452-000-010	5.25" PrLc Jet Int/Leaf, Mass. (SS/Sil/IGG/GG); 500s Jet body, 3/4SB x 3/8"SB, Compensator Ring,	1	
6	25059-300-000,	1" Variable Air Control, Leaf, Sil/IGG/Sil	3	
7	25056-310-000,	1" On-Off Control, Leaf, Sil/IGG/Sil	3	
8	25269-001-500	2.25" LED Laminar jet, Leaf	3	
8A	675-5289L-DSG	18" LED Spillway waterfall	1	
9	640-3790SGAV	251GPM Super Hi-Flo 2.5" Suction (metal)	4	
10	1219S	Light Kit 5", SS	1	
11	50390-02	Topside panel Spa Touch	1	
12	3133	Small rounded Pillow	3	
13	AQ-SPK3.0-4S	Speaker AQ-SPK	4	
14	822817	Weir door(Gr/Silver)	1	
15	1238	Filter Lid(Gr)	1	
16	61368	Cartridge Filter	2	
17	25241-507-800	LED Deco Cup Holder	5	
18	1310A, 1312A, 1318A, 1315, 1317, 1338, 25243-307-000	LED contr-r, 6-LED spyder, 2-LED spyder, 9-LED light, Cables Assy, oval Spa Light	1+7+1+2+ 1+1+4	
19	25290-000-020, 25290-009-010	Water ball Assy.	1+1	
N/A	7789, 6023, 310-0180	2 Speed Motor; 8" Cord ; Wet end 0180;	2	
N/A	7788, 6024, 310-0180	1 Speed Motor; 8" Cord ; Wet end 0180;	0	
N/A	7794, 6024, 310-0800	Circ. pump motor; 8" Cord ; Wet end 0800;	1	
N/A	56723	Balboa Pack BP2100G1	1	
N/A	5071, 7399	Ozonator w/ Cord, Injector	2+2	
N/A	7303, 7876B	Premium Owner's Manual, insert	1	
N/A	XXXX(AH,G)	Spa cover 85"x85"	1	
N/A	59019-01, 25717, CS-P80, 1142	Balboa Bluetooth Amp, Adapter cable, Passive SUB w. harness, power supply 100-230/12Vdc	1	
N/A	50350-03	Wi-Fi module	1	

Notes

Warranty

Premium Leisure, LLC ("Premium Leisure") provides a limited Warranty for the Premium Spas (the "Spa") in accordance with the time periods and other terms and conditions described below (the "Warranty"). If you have any questions regarding Warranty Issues, please contact us.

Structural and Manifold Plumbing Parts (Lifetime): Premium Leisure warrants the Spa's shell structure against the loss of water through the fiberglass laminate of the shell caused by defects in materials and workmanship. Premium Leisure also warrants that the plumbing manifold system (i.e. manifold, fittings and related parts) will be free from defects in materials and workmanship. The Warranty for these components covers only parts and extends for as long as the original purchaser owns the Spa.

Spa Surface (Five (5) years, pro-rated): Premium Leisure warrants the Spa's interior acrylic spa surface against blisters, cracks, or delaminating resulting from a defect in materials or workmanship of the acrylic surface material for a period of five (5) years from the original date of purchase. The Warranty for the acrylic spa surface covers both parts and labor, and is pro-rated based on the following formula: Suggested retail price divided by months covered (60), multiplied by months owned plus shipping = replacement cost.

Major Spa Components (Five (5) years, pro-rated): Premium Leisure warrants the Spa's major electrical equipment (electrical system, Spa controls and motors) to be free of defects in materials and workmanship for a period of two (2) years from the original purchaser's date of purchase. The Warranty on these components covers only parts, such replacement parts to be obtained directly from Premium Leisure or Assigned Agent, and defective parts returned to Premium Leisure Assigned Agent. Pro-rated formula: Year 1-2, manufacturer covers 100% of component replacement cost based on MSRP of component. Year 3, manufacturer covers 75% of component replacement cost based on MSRP of component. Year 4-5, manufacturer covers 50% of component replacement cost based on MSRP of component.

Cabinet (Two (2) year): Premium Leisure warrants the Spa's simulated wood cabinet, including the materials, structural integrity and assembly of the cabinet, will be free of defects in materials and workmanship for a period of two (2) year from the original purchaser's date of purchase. The cosmetic finish of the Spa's wood cabinet is warranted to be free from defect in materials and workmanship at time of initial delivery. Fading and weathering of the cabinet surface may occur naturally over time and shall not be considered a defect. To restore the appearance of the Spa's wood cabinet, please refer to the Spa's owner's manual for proper care and maintenance instructions.

Other Spa Components and Optional Accessory Items: All components of the Spa not described above are covered by a 90 day, parts only, Warranty. These components include, but are not limited to, the Spa's optional accessory items such as optional fixtures, trim kits, skirts, stereos, MP3 players and other music and video devices, ozone, waterfall assemblies, and lighting systems. All perishable, cosmetic or owner serviceable items, spa cover, light bulb, light lenses, fuses, headrests, filters, cover-lift, spa drain, jet inserts, etc. are warranted to be free of defects in materials and workmanship at the time of the Spa's delivery. Certain items described in this paragraph may be covered by a separate manufacturer's Warranty. Premium Leisure may serve as an agent in presenting claims under these manufacturers' warranties, but will not be responsible if such Warranty claims are limited or denied. In the event Premium Leisure provides parts to replace an alleged defective part covered by an independent manufacturer's Warranty, the Spa owner will be responsible for the item's cost and applicable shipping charges, and will be credited with item cost upon the manufacturer accepting the Warranty claim and providing Premium Leisure with a replacement item.

Warranty Performance: In the event of a suspected defect covered by the terms of this Warranty, the Spa owner must notify us within a reasonable time and use all reasonable means to protect the Spa from further damage. For a period of two (2) years a service representative will provide the technical labor only, to affect the repair subject to the terms and conditions contained in this Warranty. The service representative may assess reasonable travel charges. Visits to simply diagnose, troubleshoot, or inspect problems are not covered under this Warranty. If we determine that repairs are not feasible due to functional defect, we reserve the right to provide a replacement part or spa in lieu of repair. We will replace with a part of value equal to the original purchase. In such event, owner is responsible for expenses including removal, shipping, and re-installation of the existing or replacement Spa. The replacement Spa or part will carry the balance of the original Spa's Warranty, if any.

Limitations and Exclusions

This Warranty applies to spas sold after November 1, 2014, and takes effect from the date the Spa was originally purchased or six months from the date of manufacture whichever comes first. This Warranty applies only to the original purchaser and terminates with any transfer of ownership. This Warranty does not apply to a Spa used for any commercial, rental, club purposes, or for any Spa used outside of the United States. All Warranty claims must be accompanied by a sales invoice showing date of purchase. This Warranty does not cover damage resulting from moving the Spa, abuse, misuse, or neglect, including but not limited to any installation, operation, maintenance or use of the Spa other than in accordance with the Spa's Owner's Manual. Also excluded from this Warranty is coverage for damage caused by (a) operation of the Spa at water temperatures outside the range of 32 and 104 degrees Fahrenheit, (b) dirty, clogged, or calcified filter cartridges, (c) improper use of chemicals or cleaning agents, (d) allowing un-dissolved spa sanitizing chemicals to lie on the surface, (e) improper pH balance or other improper water chemistry, (f) failure to provide even and sufficient structural support for the Spa, (g) repairs or alterations performed by anyone other than a Premium Leisure authorized service representative, and (h) acts of God (including lightning strikes), nonstructural normal wear and tear, cosmetic blemishes and other causes beyond Premium Leisure's control.

WARRANTY DISCLAIMERS

The Warranty is in lieu of all other warranties, expressed or implied, including implied warranties of merchantability and fitness for a particular purpose. In no event shall Premium Leisure be liable for incidental or consequential damages. The Spa owner is required to provide unencumbered access to the Spa for any Warranty repair or inspection. Premium Leisure shall not be liable for loss of use of Spa or other incidental or consequential costs, expenses or damages, which may include, but are not limited to water damage, or the removal of a permanent deck or other customer fixture. Under no circumstances shall Premium Leisure, or any of its representatives, be held liable for injury to any person or damage to any property, however arising. This Warranty gives you specific legal rights and you may have other rights. Premium Leisure's waiver or failure to enforce any of the terms or conditions of the Warranty shall not in any way affect, limit or waive its right at any time to enforce strict compliance with every term and condition thereof. No service company or other party is authorized to change, modify, or extend the terms of this Warranty in any manner whatsoever. The jurisdiction and venue for any litigation arising with respect to the transaction evidenced by this Warranty shall be the Circuit Court in and for Pinellas County, Florida, and any party submitting a claim under this Warranty hereby agrees to such jurisdiction and venue.

Premium Leisure LLC

6101 45th St. N.
St. Petersburg, FL 33714
727.573.9611

www.PremiumLeisure.com